

Table of Contents

Table of Contents

Chapter 01: Distance vs. Displacement--Speed vs. Velocity	Homework # 01
Chapter 02: Equations	Homework # 09
Chapter 03: Newton's 2nd Law-1D Acceleration-Horizontal Motion	Homework # 19
Chapter 04: Planetary Data	Homework # 26
Chapter 05: Work-Constant Force	Homework # 33
Chapter 06: Momentum, Force, & Momentum Conservation	Homework # 42
Chapter 07: Angular Quantities	Homework # 50
Chapter 08: Simple Harmonic Motion-Elastic Oscillators	Homework # 59
Chapter 09: Speed & Intensity of Sound	Homework # 68
Chapter 10: Density	Homework # 72
Chapter 11:	Homework # 82
Chapter 12:	Homework # 92
Chapter 13: Electric Field Calculations Using Coulomb's Law	Homework # 102
Chapter 14:	Homework # 111
Chapter 15: Magnetic Force on a Current-Carrying Wire	Homework # 122
Chapter 16: The Biot-Savart Law (Magnetic Field Strength of Currents)	Homework # 135
Chapter 17: Alternating Current in a Resistor	Homework # 140
Chapter 18: Maxwell's Equations/Electromagnetic Waves	Homework # 145
Chapter 19: Speed of Light/Index of Refraction/EM Spectrum	Homework # 146
Chapter 20: Electromagnetic Spectrum/Refraction of Light	Homework # 156
Chapter 21:	Homework # 162
Chapter 22: Photon Theory of Light & The Photoelectric Effect	Homework # 167
Chapter 23: Selected Isotope Masses	Homework # 172

One Dimensional Kinematics

Distance vs. Displacement--Speed vs. Velocity

Homework #01

$$\Delta x = x - x_0 \quad \bar{v} = \frac{d}{t} \quad \bar{v} = \frac{\Delta x}{\Delta t} = \frac{x - x_0}{t}$$

I

01. A squirrel runs 80.0 m along a fence in 6.00 s. The squirrel stops for 2.00 s, then turns around and runs 35.0 m in 3.00 s in the opposite direction.
- What was the distance traveled by the squirrel for the first part of his journey (from 0 to 6.00 seconds)?
 - What was the displacement of the squirrel for the first part of his journey (from 0 to 6.00 seconds)?
 - What was the average speed of the squirrel for the first part of his journey (from 0 to 6.00 seconds)?
 - What was the average velocity of the squirrel for the first part of his journey (from 0 to 6.00 seconds)?
 - What was the distance traveled by the squirrel for the second part of his journey (from 6.00 to 8.00 seconds)?
 - What was the displacement of the squirrel for the second part of his journey (from 6.00 to 8.00 seconds)?
 - What was the average speed of the squirrel for the second part of his journey (from 6.00 to 8.00 seconds)?
 - What was the average velocity of the squirrel for the second part of his journey (from 6.00 to 8.00 seconds)?
 - What was the distance traveled by the squirrel for the third part of his journey (from 8.00 to 11.00 seconds)?
 - What was the displacement of the squirrel for the third part of his journey (from 8.00 to 11.00 seconds)?
 - What was the average speed of the squirrel for the third part of his journey (from 8.00 to 11.00 seconds)?
 - What was the average velocity of the squirrel for the third part of his journey (from 8.00 to 11.00 seconds)?
 - What was the total distance traveled by the squirrel during the entire trip?
 - What was the net displacement for the squirrel for the entire trip?
 - What was the average speed of the squirrel for the entire trip?
 - What was the average velocity of the squirrel for the entire trip?
02. How long does it take a car to travel 65.0 m if it is moving at 18.5 m/s?
03. A mailman walked in a straight line from one house to another, a distance of 32.5 m, in 12.7 s. What was his average velocity?
04. A plane travels from Newark airport to Orlando Florida in 2.25 hours. If the average velocity of the plane during this trip was 782 km/h, what was the magnitude of the displacement for the trip?

II

05. A runner moving through a 5.00 km course takes 21 minutes and 25 seconds to go 2920 m. He wants to finish the race in 36.0 minutes. What minimum average velocity must he run for the remainder of the course?

III

06. A runner moving through a 1600 m course takes 5 minutes and 25 seconds to go 1230 m. What must his average velocity be for the remainder of the course if his average velocity for the whole race was 3.81 m/s?

ANSWERS: **01.** a.) 80.0 m b.) +80.0 m c.) 13.3 m/s d.) +13.3 m/s e.) 0 m f.) 0 m g.) 0 m/s
01. h.) 0 m/s i.) 35.0 m j.) -35.0 m k.) 11.7 m/s l.) -11.7 m/s m.) 115.0 m n.) +45.0 m
01. o.) 10.5 m/s p.) +4.09 m/s **02.** 3.51 s **03.** 2.56 m/s **04.** 1760 km **05.** 2.38 m/s **06.** 3.89 m/s

One Dimensional Kinematics

Uniform Acceleration (Kinematic Equations)

Homework #02

$$\bar{a} = \frac{\Delta v}{\Delta t} = \frac{v - v_0}{t}, \quad v = v_0 + at, \quad x = x_0 + v_0t + \frac{1}{2}at^2, \quad v^2 = v_0^2 + 2a(x - x_0)$$

I

01. A sprinter, starting from rest, accelerates to 6.42 m/s in 1.35 s. What was his average acceleration?
02. A truck moving 80.0 km/h has the brakes applied causing it to slow down to 60.0 km/h in 6.20 s. What was its average acceleration?
03. A boat accelerates from rest at 1.28 m/s² for 9.25 s. How fast will the boat be moving after this time?
04. A skateboarder attains a speed of 16.4 m/s, then begins to coast. Friction results in a deceleration of 0.625 m/s². What will be the skateboarder's speed after 12.0 s?
05. Willie Mays hit a baseball in the gap in left-centerfield. He rounds first and is headed to second at 8.56 m/s when he begins to slide into second base. His slide causes him to decelerate at 12.4 m/s². How long does it take him to stop?
06. Police investigating an accident measure skidmarks from car A to be 37.6 m before its impact with car B. From the damage to car B, it is estimated that car A was traveling at 20.0 km/h when it impacted car B. Car A is known to have a maximum deceleration of 9.35 m/s². How fast must car A have been going before its brakes were applied?
07. On a road with a speed limit of 40 mi/h (24.9 km/h) is a traffic light located at an intersection. If a truck's maximum safe deceleration rate is 4.25 m/s².
 - a.) What is the minimum stopping distance for this truck?
 - b.) How long does it take the truck to stop?

II

08. A deranged student throws a physics book down a hallway. When the book lands on the floor it is traveling 32.0 km/h and slides down the hallway for 6.45 s before coming to a stop. How far did the book slide?
09. A motorcycle traveling 60 mi/h (37.3 km/h) down the parkway accelerates to the posted speed limit of 65 mi/h (40.4 km/h) over a distance of 3.68 m. How long did it take the motorcycle to reach the speed limit?
10. An elevator accelerates upward from rest at 0.83 m/s². How high has it risen after 3.4 s?
11. A car traveling 28.6 m/s applies the brakes and stops 4.95 s later. How far did the car travel during this time?

ANSWERS: **01.** 4.76 m/s² **02.** -0.897 m/s² **03.** 11.8 m **04.** 8.90 m/s **05.** 0.690 s
06. 97.5 km/h (27.1 m/s) **07.** a.) 5.64 m b.) 1.63 s **08.** 28.7 m **09.** 0.341 s **10.** 4.80 m **11.** 70.8 m

One Dimensional Kinematics

Freefall

Homework #03

$$\text{Quadratic Equation: } t = \frac{-b \pm \sqrt{b^2 - 4ac}}{2a}$$

I

01. A ball is dropped from the top of a 73.0-m tall building.
- How far has the ball fallen after 2.5 s?
 - What is the magnitude of the ball's velocity after 2.5 s?
 - When will the ball hit the ground below?
 - With what velocity will the ball hit the ground below?
02. A paint ball is fired straight up from ground level at 312 km/h.
- How high will it be after 6.0 s?
 - What is the ball's velocity after 6.0 s?
 - How high is the ball's highest point?
 - How high will it be after 11.0 s?
 - What is the ball's velocity after 11.0 s?
 - How long after firing the paint ball will it hit the ground?
 - With what velocity will it hit the ground?
03. A stone is thrown straight up from the top of 125-m high cliff with a velocity of 27.5 m/s.
- How long will it take to reach the highest point of its trajectory?
 - What is the velocity of the stone after 7.0 s?
 - How long will it take to hit the ground below?
 - With what velocity will the stone hit the ground below?
 - How long will it take the stone to return to the level of the cliff?
 - What will the velocity of the stone be when it returns to the level of the cliff?
- For parts g.) through i.), assume the stone was thrown straight down at 27.5 m/s from the top of this cliff.**
- How long will it take the stone to hit the ground below?
 - With what velocity will the stone hit the ground below?
 - Why is the answer to parts d.) and h.) the same?

II

04. A super-genius coyote drops a rock from the top of a 160-m high cliff, hoping to hit a roadrunner below. The clumsy coyote loses his balance and falls off the cliff exactly 2.00 s after releasing the rock. How far apart are they after the coyote has been falling for 3.00 s?
05. A baseball is thrown vertically upward with a speed of 28.0 m/s.
- How high does the ball go?
 - How long does it take to return to the ground?

ANSWERS: **01.** a.) 42.4 m b.) -24.5 m/s c.) 3.86 s d.) 37.8 m/s **02.** a.) 344 m b.) 27.9 m/s c.) 383 m
02. d.) 360 m e.) -21.1 m/s f.) 17.7 s g.) -312 km/h (-86.7 m/s) **03.** a.) 2.81 s b.) -41.1 m/s c.) 8.58 s
03. d.) -56.6 m/s e.) 5.61 s f.) -27.5 m/s g.) 2.97 s h.) -56.6 m/s **04.** 78.4 m **05.** a.) 40 m b.) 5.71 s

One Dimensional Kinematics

Freefall

Homework #04

II

06. A kangaroo jumps to a vertical height of 2.6 m. How long was it in the air before returning to earth?
07. A baseball player throws a ball vertically upward and catches it 4.65 s after it left his hand.
- With what speed did he throw it?
 - What height did it reach?
08. A helicopter is ascending vertically with a speed of 8.50 m/s. At a height of 120 m above the earth, a grenade is held out a window and released. How much time does it take for the grenade to reach the ground?
09. A baseball is seen to pass vertically upward by a third story window 30 m above the street with a speed of 54.0 km/h.
- What was the initial speed of the ball?
 - What altitude does it reach?
 - How long after it was thrown does it take to return to it's the ground (or original height)?
10. An arrow is launched vertically upward from a crossbow at 112 m/s.
- What is the arrow's instantaneous speed after 10.0 s?
 - What is the arrow's average velocity for the first 10.0 s?
 - What is the arrow's instantaneous speed after 15.0 s?
 - What is the arrow's average velocity for the first 15.0 s?
 - How long does it take for the arrow to return to the ground?
 - What is the arrow's average velocity for the trip?
11. A ball is thrown upward from the top of a 42.8-m tall building and lands on an adjacent 96.4-m tall building 4.57 s later. With what velocity will the ball land on the adjacent roof? (Ignore the small horizontal travel of the ball)

III

12. A stone is dropped from the roof of a high building. A second stone is dropped 2.50 s later. How far apart are the stones when the second one has reached a speed of 15.0 m/s?
13. A falling stone takes 0.28 s to travel past a window that is 2.6 m in height. From what height above the **TOP** of the window did the stone fall?
14. A rock is dropped from a bridge and the sound of it striking the water below is heard 3.45 s after its release. If the speed of sound is 343 m/s, how high is the bridge?
15. A garden hose nozzle is pointed vertically upward and held at a height of 1.5 m. When the faucet is turned on the water is heard to hit the ground 2.5 s later. What is the water speed as it leaves the nozzle?

ANSWERS: **06.** 1.46 s **07.** a.) 22.8 m/s b.) 26.5 m **08.** 5.89 s **09.** a.) 28.5 m/s b.) 41.5 m c.) 5.82 s
10. a.) 14.0 m/s b.) 63.0 m/s c.) -35.0 m/s d.) 38.5 m/s e.) 22.9 s f.) 0 m/s **11.** -10.7 m/s
12. 68.1 m **13.** 3.20 m **14.** 53.2 m (or 54.9 m) **15.** 11.7 m/s

One Dimensional Kinematics

Graphical Analysis-Position vs. Time

Homework #05

Position vs. Time

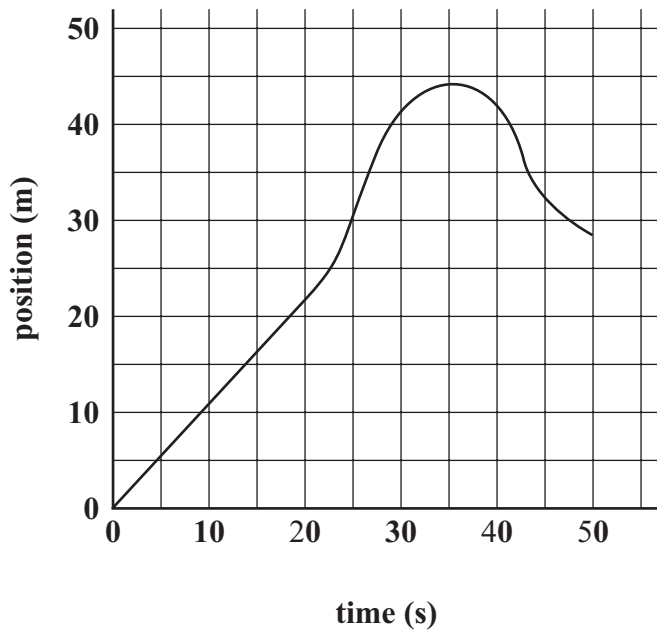

Velocity vs. Time

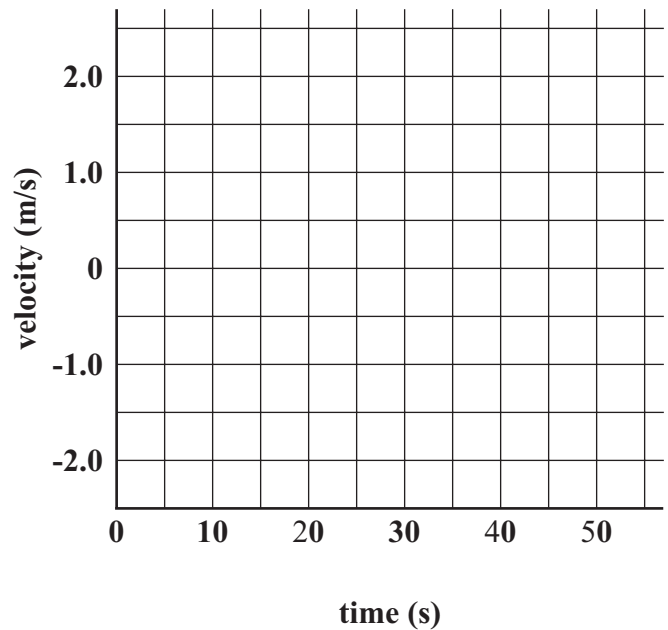

The top-left graph above is based on data obtained on a rabbit's position as he runs through a pipe.

01. What is the instantaneous velocity at 10 s?
02. What is the average velocity for the first 20 s?
03. What is the average velocity for the 20 s to 30 s time interval?
04. Estimate the instantaneous velocity at 30 s?
05. At what time does the rabbit stop running?
06. What is the average velocity for the time 40 s to 50 s time interval?
07. Estimate the instantaneous velocity at 45 s?
08. Sketch what the velocity vs. time graph would look like for this trip.
09. Sketch what the acceleration vs. time graph would look like for this trip.

Acceleration vs. Time

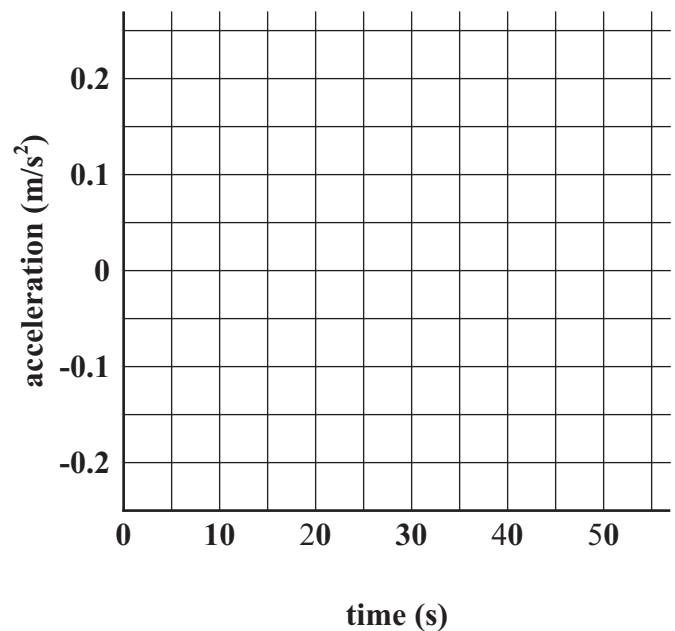

ANSWERS: 01. 1.1 m/s 02. 1.1 m/s 03. 2.0 m/s 04. 0.9 m/s 05. 35 s 06. -1.4 m/s 07. -1.0 m/s

One Dimensional Kinematics

Graphical Analysis-Velocity vs. Time

Homework #06

Velocity vs. Time

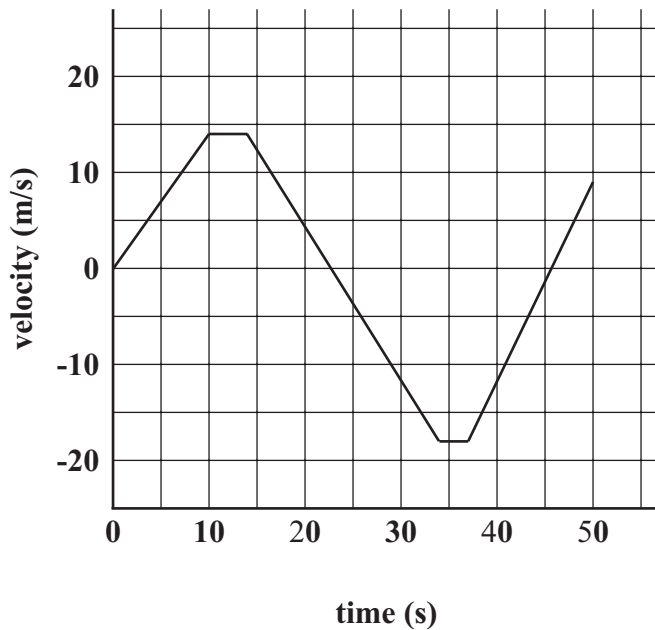

Position vs. Time

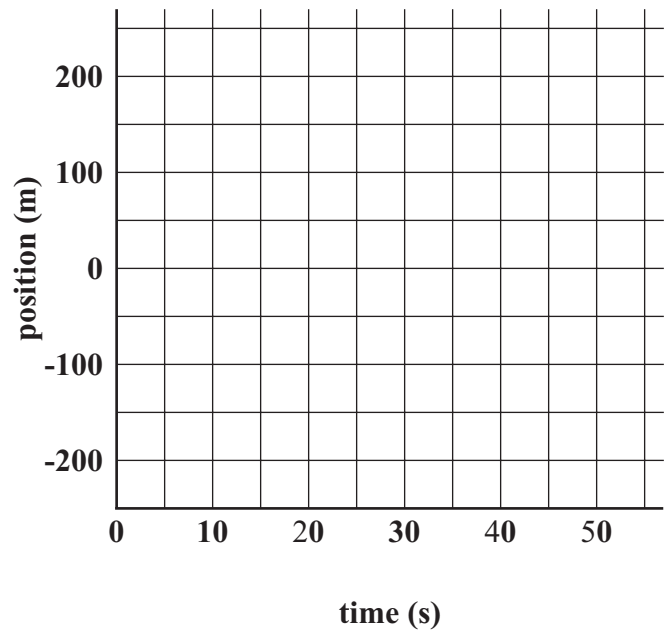

The top-left graph above is based on data obtained from observing a mouse moving through a long tube.

01. What is the instantaneous acceleration at 6 s?
02. What is the average acceleration for the first 10 s?
03. What is the average acceleration for the 20 s to 30 s time interval?
04. At what times is the rat at rest?
05. At what times is the acceleration rate 0 m/s^2 ?
06. Estimate the rat's displacement after the first 10 s?
07. Estimate the rat's displacement after the first 30 s?
08. Estimate the rat's displacement at the end of 50 s?
09. Sketch what the position vs. time graph would look like for this trip.
10. Sketch what the acceleration vs. time graph would look like for this trip.

Acceleration vs. Time

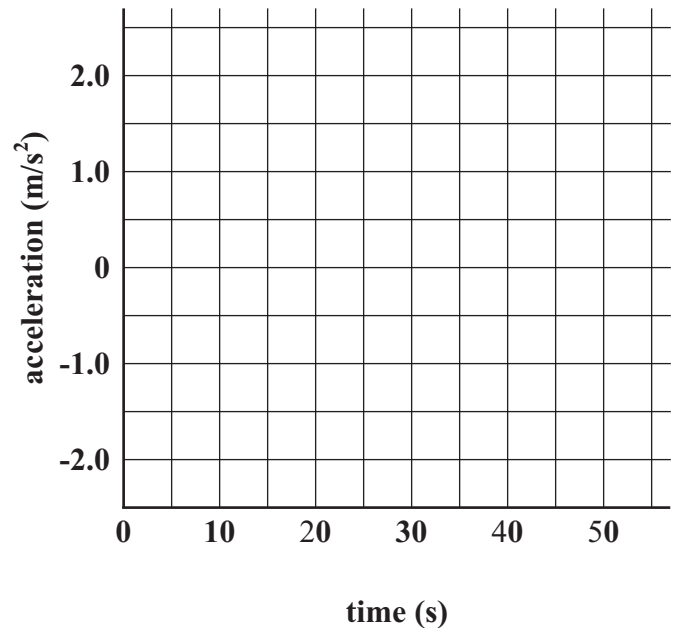

ANSWERS: **01.** 1.4 m/s^2 **02.** 1.4 m/s^2 **03.** -1.6 m/s^2 **04.** 23 s, 46 s **05.** 10 s - 14 s, 33 s - 37 s
06. 70 m **07.** 147 m **08.** -37 m

One Dimensional Kinematics

Graphical Analysis-Acceleration vs. Time

Homework #07

Acceleration vs. Time

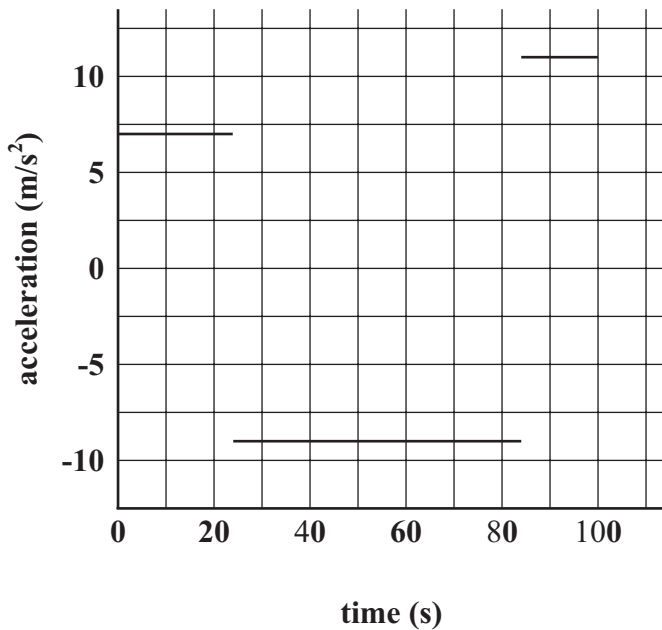

Velocity vs. Time

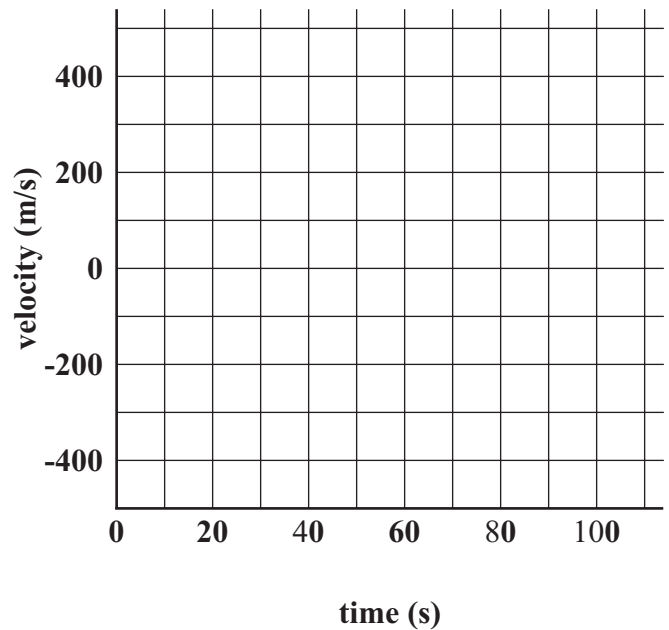

The top-left graph above is based on data obtained from a unknown lab by a unknown physics student . Assume the object in this lab started from rest.

01. What is the velocity of this object after 20 s?
02. What is the velocity of this object after 30 s?
03. What is the velocity of this object after 80 s?
04. What is the velocity of this object after 100 s?
05. Sketch what the velocity vs. time graph would look like for this trip.
06. Sketch what the position vs. time graph would look like for this trip.

Position vs. Time

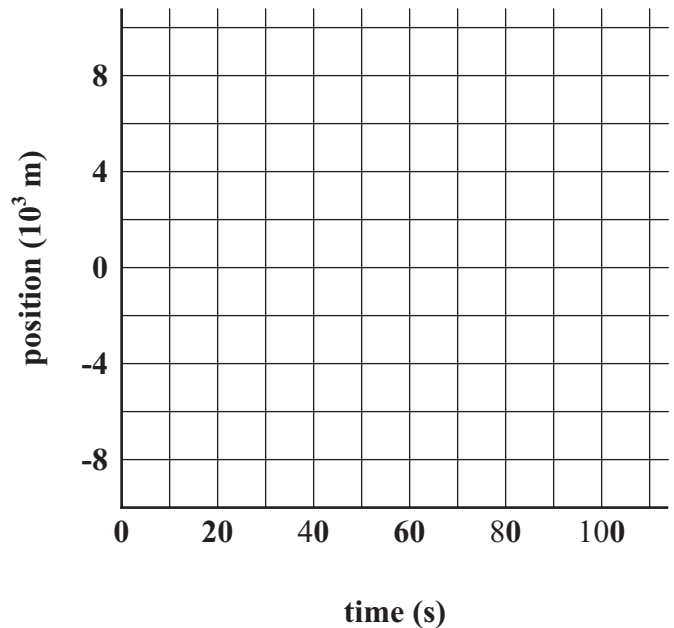

ANSWERS: 01. 140 m/s 02. 114 m/s 03. -336 m/s 04. -196 m/s

One Dimensional Kinematics

Conceptual Review

Homework #08

01. Does a car speedometer measure speed, velocity, or both? Explain.
02. If an accurate speedometer registers a constant value for a period of time, can you determine the average velocity over that period of time using only the speedometer? Explain.
03. Can the average velocity of a particle be zero over a given time interval if it is not zero over a shorter time interval? Explain.
04. Can an object have a varying velocity if its speed is constant? If yes, give examples; if no, explain why.
05. Can an object have a varying speed if its velocity is constant? If yes, give examples; if no, explain why.
06. When an object moves with a constant velocity, does its average velocity during any time interval differ from its instantaneous velocity at any instant? Explain.
07. Can the velocity of an object be zero at the same instant its acceleration is not zero? Give an example.
08. If one object (Object A) has a greater speed than another object (Object B) does it (Object A) necessarily have a greater acceleration? Explain, using examples.
09. Compare the acceleration of a motorcycle that accelerates from 80 km/h to 90 km/h with the acceleration of a bicycle that accelerates from rest to 10 km/h in the same time.
10. Can you conclude that a car is not accelerating if its speedometer indicates a steady 60 km/h? Explain.
11. Can an object have a northward velocity and a southward acceleration? Explain.
12. Can the velocity of an object be negative if its acceleration is positive? What about vice versa? Explain.
13. Give an example where both velocity and acceleration are negative.
14. A rock is thrown vertically upward with a speed of v from the edge of a cliff. A second rock is thrown vertically downward with the same initial speed. Which rock has the greater speed when it reaches the bottom of the cliff? Ignore air resistance.
15. A ball, thrown vertically upward, returns to the thrower's hand. Which part of the journey requires the longer time, upward or downward? Answer for (a) no air resistance, and (b) in the presence of air resistance.
16. An object that is thrown vertically upward will return to its original position with the same speed as it had initially, if air resistance is negligible. If air resistance is appreciable, will this result be altered, and if so, how?
17. How do you convert km/h to m/s?
18. How do you convert m/s to km/h?

Two Dimensional Kinematics

Equations

Homework #09

Pythagorean Theorem

$$a^2 + b^2 = c^2$$

Trigonometric Definitions

$$\cos \theta = \frac{a}{h}$$

$$\sin \theta = \frac{o}{h}$$

$$\tan \theta = \frac{o}{a}$$

Trigonometric Identities

$$\tan \theta = \frac{\sin \theta}{\cos \theta}$$

$$\cos^2 \theta + \sin^2 \theta = 1$$

$$2 \cdot \sin \theta \cdot \cos \theta = \sin 2\theta$$

Projectile Motion Equations

x	y
$v_x = v_{x0}$	$v_y = v_{y0} + gt$
$x = v_{x0}t$	$y = y_0 + v_{y0}t + \frac{1}{2}gt^2$
	$v_y^2 = v_{y0}^2 + 2g(y - y_0)$
	$\bar{v}_y = \frac{v_{y0} + v_y}{2}$

Two Dimensional Kinematics

Graphical Addition of Vectors

Homework #10

For each of numbers 1-3, execute the following operations on vectors **A**, **B**, and **C**: a.) $A + B + C$ and b.) $A + B - C$
Note: Include the arrowhead in any measurements of length. A margin of error of ± 0.3 cm and $\pm 4^\circ$ is allowed.

01.

a.) Resultant = $\frac{\quad}{\text{Magnitude}}$ @ $\frac{\quad}{\text{Direction}}$

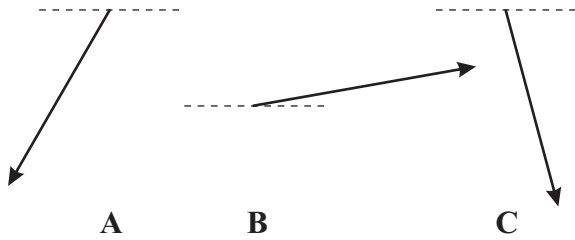

b.) Resultant = $\frac{\quad}{\text{Magnitude}}$ @ $\frac{\quad}{\text{Direction}}$

02.

a.) Resultant = $\frac{\quad}{\text{Magnitude}}$ @ $\frac{\quad}{\text{Direction}}$

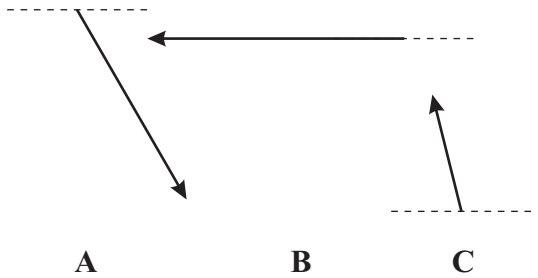

b.) Resultant = $\frac{\quad}{\text{Magnitude}}$ @ $\frac{\quad}{\text{Direction}}$

03.

a.) Resultant = $\frac{\quad}{\text{Magnitude}}$ @ $\frac{\quad}{\text{Direction}}$

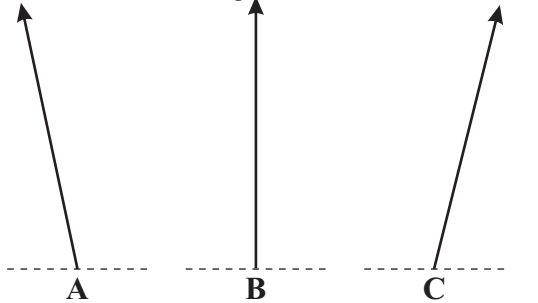

b.) Resultant = $\frac{\quad}{\text{Magnitude}}$ @ $\frac{\quad}{\text{Direction}}$

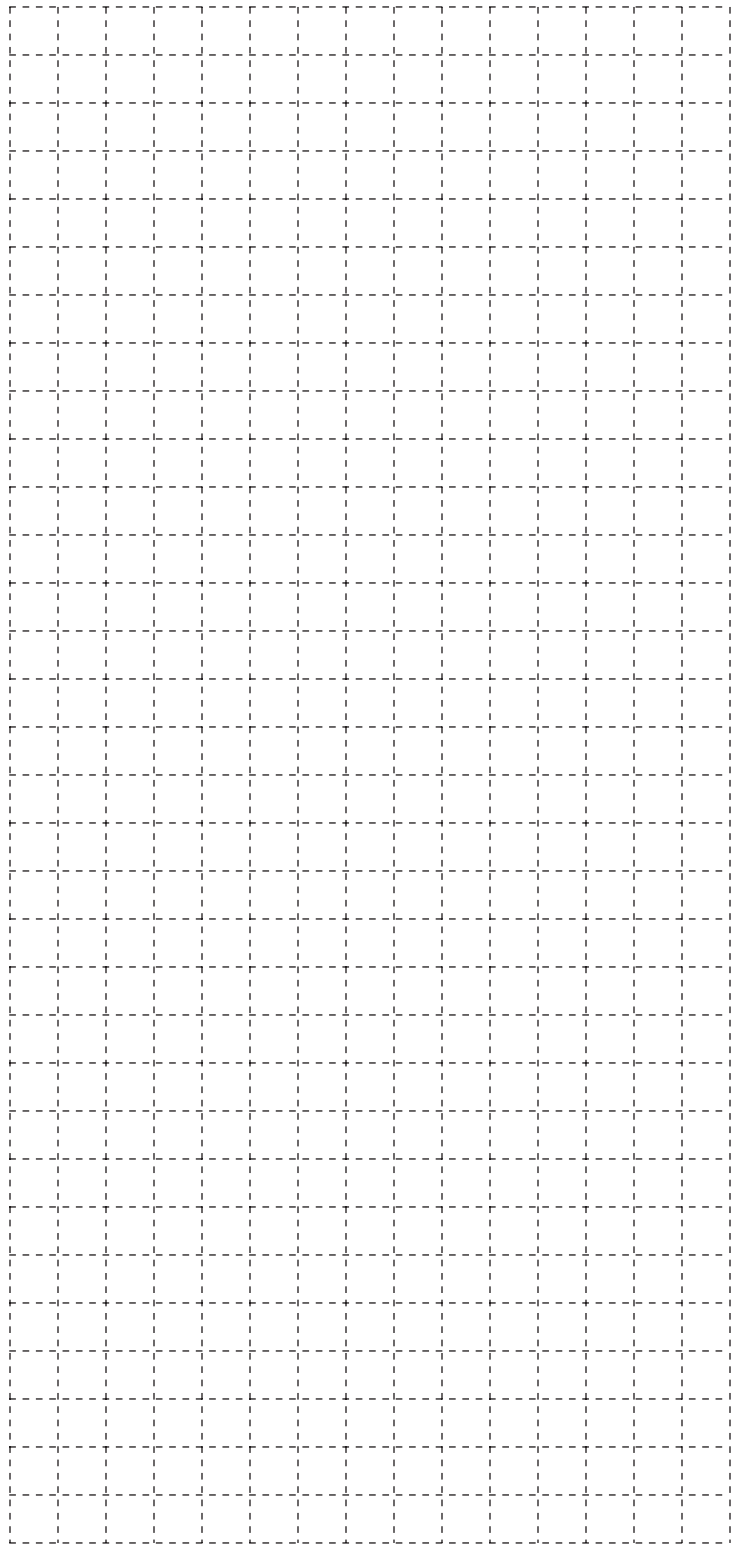

ANSWERS: 01. a.) 5.0 cm @ 62° S of E b.) 1.2 cm @ 40° N of E
 02. a.) 2.5 cm @ 21° S of W b.) 4.3 cm @ 69° S of W 03. a.) 10.2 cm @ 89° S of E b.) 4.0 cm @ 65° N of W

Two Dimensional Kinematics

Graphical Addition of Vectors

Homework # 11

For each of numbers 4-6, execute the following operations: a.) $A + B + C$ and b.) $A + B - C$

Note: Include the arrowhead in any measurements of length. A margin of error of ± 0.3 cm and $\pm 4^\circ$ is allowed.

04.

a.) Resultant = $\frac{\quad}{\text{Magnitude}}$ @ $\frac{\quad}{\text{Direction}}$

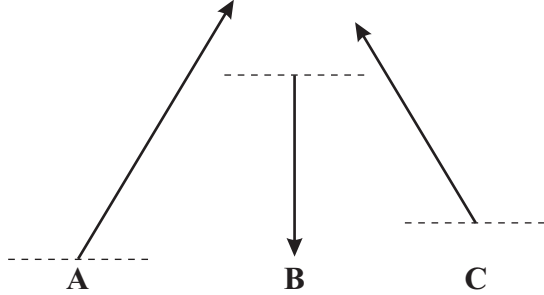

b.) Resultant = $\frac{\quad}{\text{Magnitude}}$ @ $\frac{\quad}{\text{Direction}}$

05.

a.) Resultant = $\frac{\quad}{\text{Magnitude}}$ @ $\frac{\quad}{\text{Direction}}$

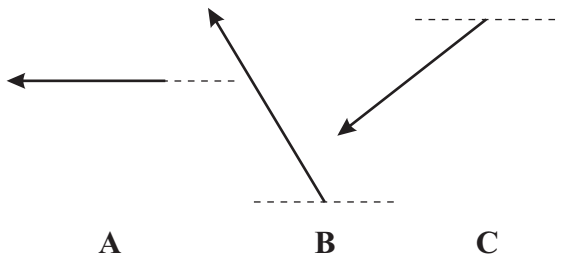

b.) Resultant = $\frac{\quad}{\text{Magnitude}}$ @ $\frac{\quad}{\text{Direction}}$

06.

a.) Resultant = $\frac{\quad}{\text{Magnitude}}$ @ $\frac{\quad}{\text{Direction}}$

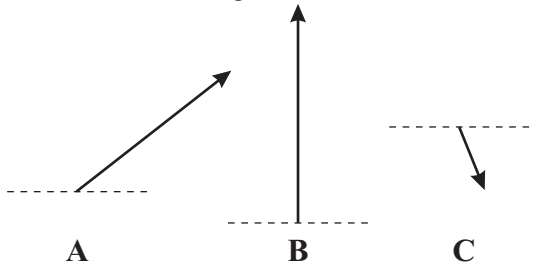

b.) Resultant = $\frac{\quad}{\text{Magnitude}}$ @ $\frac{\quad}{\text{Direction}}$

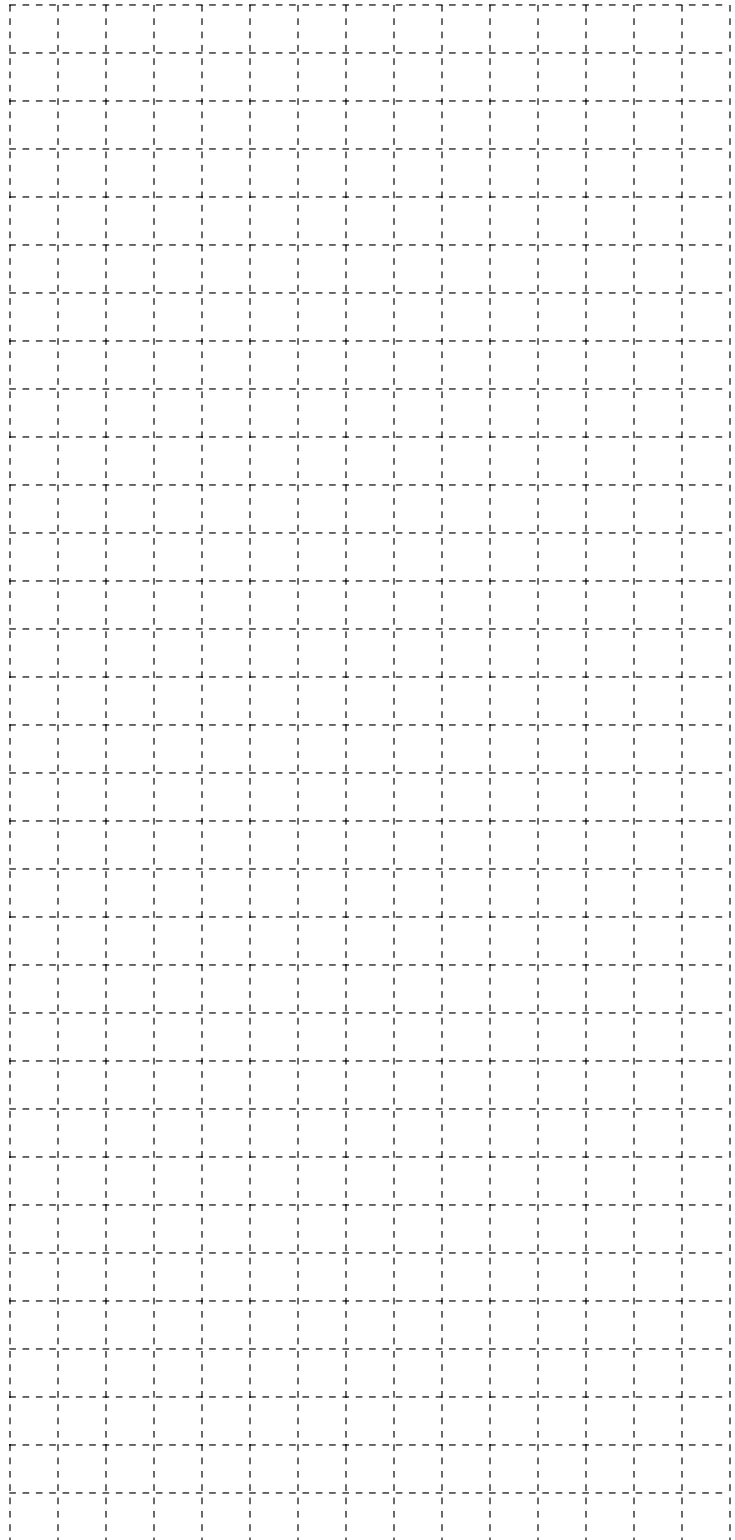

ANSWERS: 04. a.) 3.7 cm @ 82° N of E b.) 4.0 cm @ 24° S of E
05. a.) 5.7 cm @ 11° N of W b.) 4.4 cm @ 67° N of W 06. a.) 4.3 cm @ 57° N of E b.) 5.5 cm @ 72° N of E

Two Dimensional Kinematics

Trigonometry & Vector Components

Homework # 12

01.

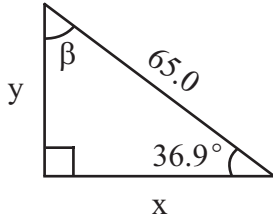

x = _____

y = _____

β = _____

02.

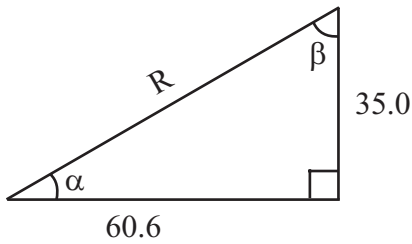

R = _____

α = _____

β = _____

03.

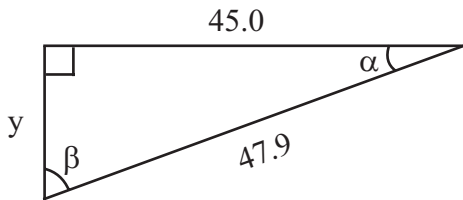

y = _____

α = _____

β = _____

04. Break each of the following vectors into components.

a.)

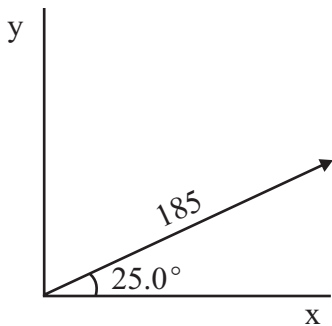

b.)

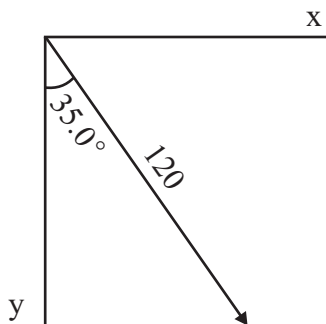

c.)

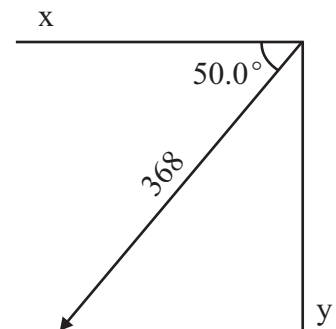

ANSWERS: **01.** x = 52.0, y = 39.0, β = 53.1° **02.** R = 70.0, α = 30°, β = 60° **03.** y = 16.4, α = 20°, β = 70°
04. a.) x = 168, y = 78.2 b.) x = 68.8, y = -98.3 c.) x = -237, y = -282

Two Dimensional Kinematics

Analytical Vector Addition

Homework #13

01. For each of the following, add the two vectors shown.

a.)

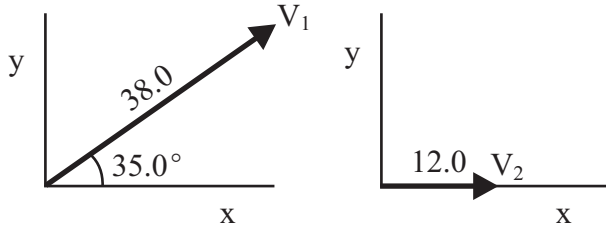

$$V_{1x} = \underline{\hspace{2cm}} \quad V_{1y} = \underline{\hspace{2cm}}$$

$$V_{2x} = \underline{\hspace{2cm}} \quad V_{2y} = \underline{\hspace{2cm}}$$

$$V_{Rx} = \underline{\hspace{2cm}} \quad V_{Ry} = \underline{\hspace{2cm}}$$

$$V_R = \underline{\hspace{2cm}} @ \underline{\hspace{2cm}}$$

b.)

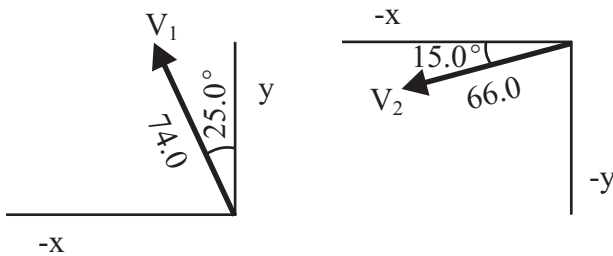

$$V_{1x} = \underline{\hspace{2cm}} \quad V_{1y} = \underline{\hspace{2cm}}$$

$$V_{2x} = \underline{\hspace{2cm}} \quad V_{2y} = \underline{\hspace{2cm}}$$

$$V_{Rx} = \underline{\hspace{2cm}} \quad V_{Ry} = \underline{\hspace{2cm}}$$

$$V_R = \underline{\hspace{2cm}} @ \underline{\hspace{2cm}}$$

c.)

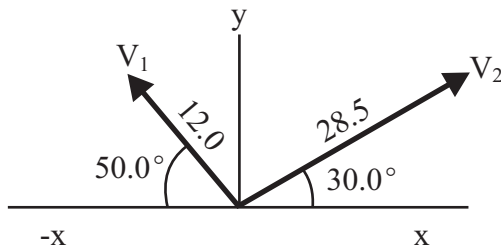

$$V_{1x} = \underline{\hspace{2cm}} \quad V_{1y} = \underline{\hspace{2cm}}$$

$$V_{2x} = \underline{\hspace{2cm}} \quad V_{2y} = \underline{\hspace{2cm}}$$

$$V_{Rx} = \underline{\hspace{2cm}} \quad V_{Ry} = \underline{\hspace{2cm}}$$

$$V_R = \underline{\hspace{2cm}} @ \underline{\hspace{2cm}}$$

02. A 4.80-m clothesline is hung between two poles that are 4.76 m apart. If a weight is hung in the very center, how much below the level of knots will the weight sit. (Assume the knots of the clothesline on each pole is at the same height and ignore any loss in the length of the line needed to tie the line on each pole).

03. A person walks 80.0 m east, then 25.0 m north. What is his final displacement?

04. A person walks 120 m west, then 65.0 m north, then 30.0 m east. What is his final displacement?

05. A person walks 40.0 m at 28.0° N of W, then walks 15.0 m at 37.0° N of E. What is his final displacement?

ANSWERS: **01.** a.) 48.3 @ 26.8° N of E b.) 107 @ 27.7° N of W c.) 28.9 @ 54.0° N of E **02.** 0.309 m
03. 83.8 m @ 17.4° N of E **04.** 111 m @ 35.8° N of W **05.** 36.2 m @ 49.9° N of W

Two Dimensional Kinematics

Relative Velocities

Homework # 14

I

01. A train is traveling down a track in a straight line at a constant velocity of 85 m/s. A boy is sitting on the floor at the back of a railroad car facing toward the front, while his sister is sitting at the front of the car facing him.
- If the boy rolls a ball toward the girl with a speed of 25 m/s relative to the train, what is the velocity of the ball as seen by an observer on the Earth?
 - If the girl rolls a ball toward the boy with a speed of 25 m/s relative to the train, what is the velocity of the ball as seen by an observer on the Earth?
02. A cyclist, we'll call him rider A, is riding a bike in an easterly direction at 40 km/h. A second rider, rider B is riding his bike at 25 km/h at a distance in front of rider A.
- If rider B is heading west, what is the velocity of rider A to B? What is the velocity of rider B to A?
 - If rider B is heading east, what is the velocity of rider A to B? What is the velocity of rider B to A?

II

03. A boat, capable of traveling 12.2 km/h in still water, motors at full speed in a heading that is directly across a 820-m wide river with a current of 5.40 km/h.
- What is the velocity of the boat as seen by an observer on the shore?
 - How far downstream will the boat land?
 - How long will it take for the boat to cross the river?
 - What is the net displacement of the boat as seen by an observer on the shore?
04. A motorboat, capable of traveling 3.85 m/s in still water, wishes to land at a port directly across a 428-m wide river. At what upstream angle must the boat head if the speed of the current is 1.12 m/s?
05. A boat, capable of traveling 10.8 km/h in still water, motors at full speed in a heading that is directly across a 740-m wide river with a current of 4.65 km/h. What is the net displacement of the boat as seen by a person on the shore?

III

06. A ferryboat, capable of traveling 1.95 m/s in still water, is crossing a 340-m wide river. The captain wishes to land at a port that is 120 m upstream. He calculates that to do so he must head the boat, motoring at full speed, at an angle of 40° upstream to successfully arrive at this port. What is the speed of the river's current?
07. An airplane, whose airspeed is 440 km/h, is heading on a course that is 23.0° N of W when it encounters a wind of 38.5 km/h that is blowing 65.0° S of E. What is the velocity of the plane as seen by an observer on the ground?
08. A plane traveling at 480 km/h is heading due north when it encounters a 42.0 km/h wind blowing **FROM** the SW.
- What is the velocity of the plane as seen by an observer on the ground?
 - How far off course will the plane be after 20 minutes?

ANSWERS: **01.** a.) 110 m/s b.) 60 m/s **02.** a.) 65 km/h b.) 15 km/h
03. a.) 13.3 km/h @ 23.9° with a line perpendicular to the shore b.) 363 m c.) 0.0673 h = 242 s
03. d.) 897 m @ 23.9° with a line perpendicular to the shore **04.** 16.9° **05.** 806 m @ 23.3° **06.** 0.724 m/s
07. 412 km/h @ 19.4° N of W **08.** a.) 511 km/h @ 86.7° N of E b.) 9.90 km E (or 14.0 km NE)

Two Dimensional Kinematics

Relative Velocities

Homework # 15

I

01. A cat walks at a speed of 1.65 m/s along the deck of a boat towards the bow. The boat is traveling at 6.60 m/s with respect to the water.
- What is the velocity of the cat with respect to the water?
 - What would be the velocity of the cat with respect to the water if it were walking toward the stern at this speed?
02. Two trains approach each other on parallel tracks. One is moving at a speed of 65 km/h relative to the earth while the other is moving in the opposite direction at 80 km/h relative to the earth. If they are initially 18 km apart, how long will it take before they pass each other?

II

03. A vacationer walks 3.50 km/h directly across (from starboard to port) a cruise ship whose speed relative to the earth is 11.4 km/h. What is the velocity of the vacationer with respect to the earth?
04. A swimmer is capable of swimming 1.35 m/s in still water. He heads directly across a 180-m wide river with a current of 0.85 m/s.
- What is the velocity of the swimmer as seen by his friend on the shore?
 - How far downstream will he land?
 - How long will it take him to reach the other side?
 - What is his displacement as seen by his friend?
05. At what upstream angle must the swimmer in problem 04 aim if he is to arrive at a point directly across the river?
06. Two cars approach a street corner at right angles to each another. Car A travels at 55.0 km/h while car B at 47.5 km/h.
- What is the velocity of car A as seen by car B?
 - What is the velocity of car B as seen by car A?

III

07. A motorcycle traveling 95.0 km/h approaches a car in front of it traveling 83.5 km/h in the same direction. When the motorcycle is 65.0 m behind the car, the rider turns the throttle to accelerate and passes the car 12.0 s later. What was the acceleration of the motorcycle?
08. An unmarked police car traveling at 95.0 km/h is passed by a speeder traveling at a constant 125.0 km/h. Exactly 1.00 s after the speeder passes the policeman steps on the accelerator. If the police car's acceleration is 2.25 m/s^2 , how much time elapses between when the police car is first passed and he overtakes the speeder?
09. A helicopter heads due south with an air speed of 40.0 km/h. The pilot observes, however, that he has covered 20.0 km in the previous 45.0 minutes in a southwesterly direction. What is the wind speed and direction?

ANSWERS: **01.** a.) 8.25 m/s to the bow b.) 4.95 m/s to the bow **02.** 0.124 h = 7.45 min
03. 11.9 km/h @ 17.1° **04.** a.) 1.60 m/s @ 32.2° with a line perpendicular to the shore b.) 113 m c.) 133 s
04. d.) 213 m @ 32.2° with a line perpendicular to the shore **05.** 39.0°
06. a.) 72.7 km/h @ 49.2° b.) 72.7 km/h @ 40.8° **07.** 0.536 m/s^2 **08.** 11.4 s **09.** 28.3 km/h @ 48.1° N of W

Two Dimensional Kinematics

Projectile Motion

Homework # 16

I

01. A marble is launched horizontally off a 93.0-cm high table causing the marble to land on the floor 1.85 m from the base of the table.
- How long was the ball in the air?
 - With what velocity must the marble have left the tabletop?
02. A baseball is thrown horizontally off a 92.8-m high cliff with a velocity of 16.7 m/s.
- How long was the ball in the air?
 - How far from the base of the cliff did the ball land?
03. A projectile is fired with an initial velocity of 80.0 m/s at a 30.0° angle from the top of a 120.0-m high cliff.
- What is the horizontal component of the projectile's initial velocity?
 - What is the vertical component of the projectile's initial velocity?
 - How high is the ball above the ground below when it is at its highest point in the trajectory?
 - What is the velocity of the projectile when it is at its highest point of the trajectory?
 - How long does it take to reach the highest point of the trajectory?
 - How long does it take to return to the height of the cliff?
 - How long does it take to hit the ground below?
 - How far from the base of the cliff will the projectile land?

II

04. A tennis ball is to be thrown horizontally from the top of a 86.4-m tall building to the roof of an adjacent 57.3-m tall building that is 25.0 m away. With what minimum speed must the ball be thrown?
05. A football is kicked from a tee at an angle of 40.0° . If the ball lands 38.6 m away and is in the air for 5.60 s, what was the initial speed of the ball?
06. A golf ball is hit with a velocity of 55.0 m/s as it leaves the tee and is angled at 50.0° from the top of a platform at a golf range that is 20.0 m above the ground.
- What horizontal distance does the golf ball travel?
 - With what velocity does the golf ball hit the ground below?
07. A bullet is fired with an initial velocity of 160.0 m/s at a 45.0° angle from the top of a 135.0-m high cliff.
- How high is the ball above the ground below when it is at its highest point in the trajectory?
 - How far from the base of the cliff will the projectile land?
 - With what velocity does the bullet hit the ground below?

III

08. Water leaves the nozzle of a sprinkler at ground level with a speed of 8.65 m/s and is observed to hit the ground 5.25 m away. At what angles could the hose be held at? Why are there two answers?

ANSWERS: **01.** a.) 0.436 s b.) 4.25 m/s **02.** a.) 4.35 s b.) 72.6 m **03.** a.) 69.3 m/s b.) 40.0 m/s
03. c.) 202 m d.) 69.3 m/s e.) 4.08 s f.) 8.16 s g.) 10.5 s h.) 728 m **04.** 10.3 m/s **05.** 9.00 m/s
06. a.) 320 m b.) 58.5 m/s @ 52.8° below the horizontal **07.** a.) 786 m b.) 2732 m
07. c.) 168 m/s @ 47.7° below the horizontal **08.** a.) 21.7° , 68.3°

Two Dimensional Kinematics

Projectile Motion

Homework #17

I

01. A diver running 2.15 m/s dives out horizontally from the edge of a cliff and reaches the water below 2.50 s later.
- How high is the cliff?
 - How far from the base of the cliff did the diver hit the water?
02. A tiger leaps horizontally from a 12.3-m-high cliff with a speed of 4.25 m/s. How far from the base of the rock will the tiger land?

II

03. A stone is cast horizontally at 25.0 m/s from a bridge spanning a river. If the stone lands 35.0 m away from the supports of the bridge, how high must be the height of the bridge?
04. A football is kicked from a tee at 18.5 m/s at a 40.0° angle to the horizontal.
- How high will the ball go?
 - What's its hang time? (for non-Americans, hang time is how long the ball is in the air)
 - How far from the initial placement of the tee will the ball land?
05. A marksman aims a rifle directly at a target that is 185 m away and on the same level as his rifle. If the bullet leaves his gun at 480 m/s, by how much will he miss his target?
06. A shotputter puts the shot (mass = 7.3 kg) with an initial speed of 15.0 m/s at a 35.0° angle to the horizontal. If the shot leaves the athlete's hand at a height of 2.25 m, what horizontal distance will the athlete score?
07. A long jumper leaves the ground at a 30.0° angle and travels 8.50 m. What was his takeoff speed?
08. An apple sits atop the head of William Tell's son who is 40.0 m away from his father. If he is to launch William Tell arrow at 37.5 m/s, at what upward angle must he aim an arrow to split the apple on his son's head? Assume the arrow leaves the bow at the same level as the apple.
09. A cannon sits on top of a castle built upon a cliff overlooking the sea. The cannon rests 185.0 m above the sea. When the cannon is fired the cannonball leaves the barrel at speed of 28.0 m/s. The cannon is raised to a 20.0° angle above the horizontal. How far away must a ship be if the cannonball is to hit the ship?

III

10. A military helicopter is flying at a constant 240 km/h horizontally. The soldiers inside wish to drop an explosive onto an enemy truck traveling at a constant speed of 125.0 km/h on a level straight highway that is 112.0 m below. At what angle below the horizontal (as shown to the right) should the truck be in their sights when the bomb is dropped?

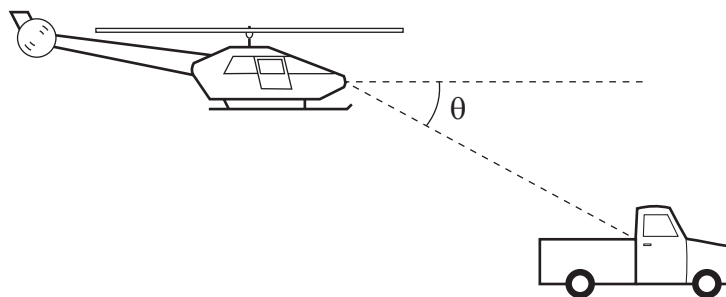

ANSWERS: **01.** a.) 30.6 m b.) 5.38 m **02.** 6.73 m **03.** 9.60 m **04.** a.) 7.21 m b.) 2.43 s c.) 34.4 m
05. 0.728 m **06.** 24.4 m **07.** 9.81 m/s **08.** 8.09° **09.** 187.0 m **10.** 36.2°

Two Dimensional Kinematics

Conceptual Review

Homework # 18

01. Does the odometer measure a scalar or vector quantity? What about the speedometer? Explain.
02. Give several examples of an object's motion in which a great distance is traveled but the displacement is zero?
03. Can the displacement vector for a particle moving in two dimensions ever be longer than the length of the path traveled by the particle over the same time interval? Can it ever be less? Can it ever be equal? Explain.
04. A baseball player hits a very high popfly, then runs in a straight line and catches it. Which had the greater displacement, the player or the ball? Which had the greater average velocity? Explain.
05. If $\vec{V}_R = \vec{V}_1 + \vec{V}_2$, is V_R necessarily greater than V_1 and/or V_2 ? Explain.
06. Two vectors have length of $V_1 = 3.5$ km and $V_2 = 4.0$ km. What are the maximum and minimum magnitudes of their vector sum?
07. Can two vectors of unequal magnitude add up to give the zero vector? Can three unequal vectors? Under what conditions? Explain.
08. Can the magnitude of a vector ever be equal to one of its components? Can it ever be less than one of its components? Explain.
09. Can a vector of magnitude zero have a nonzero component? Explain.
10. One car travels due east at 40 km/h, and a second car travels north at 40 km/h. Are their velocities equal? Discuss.
11. Two rowers, who can row at the same speed in still water, set off across a river at the same time. One heads straight across and is pulled downstream somewhat by the current. The other one heads upstream at an angle so as to arrive at a point opposite the starting point. Which rower reaches the other side first? Explain.
12. Two cars with equal speed approach an intersection at right angles to each other. Will they necessarily collide? Show that when the relative velocity of approach is collinear (along the same line) with the relative displacement, we use the nautical maxim "constant bearing means collision."
13. What physical factors are important for an athlete doing the broad jump? What about the high jump?
14. A projectile has the least speed at what point in its path?
15. A child wishes to determine the speed a slingshot imparts to a rock. How can this be done using only a meter stick and a calculator?

Dynamics: Motion and Force

Newton's 2nd Law-1D Acceleration-Horizontal Motion Homework #19

I

- A net force of 185.0 N is acting on a 25.0 kg object initially at rest.
 - What is the acceleration of the object?
 - What is the velocity of the object after 8.25 s?
- For the brief moment that a baseball bat is in contact with the baseball as a batter hits a pitched ball, the ball "feels" a force of 27,100 N causing it to accelerate at an incredible $193,600 \text{ m/s}^2$. What is the mass of the baseball?
- How much tension must a rope withstand if it is to accelerate a 1400.0-kg car at 0.85 m/s^2 . (Ignore friction)
- How much force is needed to accelerate a bicycle and its rider (total mass 125-kg) at a rate of 2.15 m/s^2 ?
- A net force of 285 N accelerates an object at 5.35 m/s^2 . What is the mass of the object?

II

- What average force is required to stop a 1200.0-kg car in 6.50 s if it is traveling 82.5 km/h?
- A 0.145-kg baseball traveling 38.5 m/s strikes the catchers mitt causing it to recoil backward 13.5 cm as the ball is brought to rest. What was the average force applied by the glove on the ball?
- Santa's sleigh, which has a mass of 62.5 kg (without Santa as an occupant), is pulled by eight tiny reindeer with an average force of 8350 N over a 60.0-m stretch of snow before becoming airborne. Assuming the sleigh started from rest, what was the sleigh's takeoff speed? (Ignore friction)
- A man pushes an 58.5-kg sofa 2.55 m across a carpet with a force of 315 N. If the retarding force (frictional force) is 280N, how long does it take the man to move sofa? (Assume it started from rest)
- A 170-g hockey puck leaves a hockey stick with an initial velocity of 11.2 m/s. If the puck travels 64.5 m, what is the retarding force on the puck from the ice?
- A 73.2-kg man runs 4.50 m/s into a padded wall. If the wall exerts an average force of 18,000 N to the man, how far did the padding compress to stop the man?

ANSWERS: **01.** a.) 7.40 m/s^2 b.) 61.1 m/s **02.** 140 g **03.** 1190 N **04.** 269 N **05.** 53.3 kg **06.** 4234 N
07. 796 N **08.** 127 m/s **09.** 2.92 s **10.** 0.165 N **11.** 4.12 cm

Dynamics: Motion and Force

Newton's 2nd Law-1D Acceleration-Vertical Motion Homework #20

I

01. A 16.5-kg box is sitting on the floor.
a.) What minimum force is needed to lift the box?
b.) If an upward force of 250.0 N is applied to the box, what will be its acceleration?
02. An upward force of 45.0 N is applied to catch a falling girl's bowling ball with a mass of 5.45 kg (12 lb). What is the acceleration of the ball?

II

03. An 800.0-N marine is trying to pull himself to the top of a 10.0-m high rope. If he pulls himself upward with an average force of 825.0 N, how long will it take him to reach the top?
04. A 103.0-kg SWAT team member descends a 27.5-m cable attached to a helicopter. If he wishes to reach the bottom in 3.50 s, what average force should he apply to the cable?
05. What minimum force is needed to lift a 3.72-kg object off the floor up onto the table 82.5 cm above?
06. A 640-kg elevator is supported by a cable. Find the tension in the cable if the elevator is _____.
a.) moving up at a constant speed of 3.00 m/s
b.) moving down at a constant speed of 3.00 m/s
c.) accelerating up at a constant speed of 3.00 m/s²
d.) accelerating down at a constant speed of 3.00 m/s²
07. A 0.100-g spider is descending a web strand by applying a force of 5.65×10^{-4} N. What is the acceleration of the spider? Ignore air resistance.
08. What is the average force exerted by a shotputter on a 7.26-kg shot if it is moved vertically through a distance of 2.75 m and is released with a speed of 12.5 m/s?
09. A 3250-kg elevator is designed to provide a maximum acceleration of 0.0750 g. What are the maximum and minimum forces the motor should exert on the supporting cable?
10. What is the acceleration of a 87.5-kg skydiver at a moment when the air resistance exerts a force of 275.0 N?
11. The supporting cable of a 1925-kg elevator has a maximum strength of 23,275 N. What maximum acceleration can it give the elevator without breaking?

III

12. A person jumps from a tower 4.65 m high. As he lands, his knees bend so that his torso decelerates over a distance of approximately 0.675 m. If the mass of his torso is 47.5 kg, what average force did his legs provide on his torso during the deceleration? Hint: Find his velocity just before he hits the ground as a start to the problem.

ANSWERS: **01.** a.) 162 N b.) 5.35 m/s² **02.** -1.54 m/s² **03.** 8.08 s **04.** 547 N **05.** 36.5 N
06. a.) 6270 N b.) 6270 N c.) 8190 N d.) 4350 N **07.** -4.15 m/s² **08.** 91.8 N
09. 34,239 N; 29,461 N **10.** -6.66 m/s² **11.** 2.29 m/s² **12.** 3675 N

Dynamics: Motion and Force

Newton's 2nd Law-2D Acceleration-Force Vectors

Homework #21

I

01. A child pulls on the handle of a 12.5-kg wagon with a force of 85.0 N. If the handle is making a 30.0° angle with the ground, what is the acceleration of the wagon (ignore frictional losses)?

II

02. A man pushes a 13.5-kg lawnmower at a constant speed with a force of 75.0 N directed along the handle which is at an angle of 45.0° with the horizontal. Calculate _____.

- a.) the horizontal retarding force on mower
- b.) the normal force exerted vertically upward on the mower by the ground
- c.) the force the man must exert on the handles of the mower to accelerate it from rest to 1.50 m/s in 2.50 s

03. A 67.5-kg sprinter exerts a force of 775 N on the starting block which is on a 20.0° with respect to the ground.

- a.) What was the horizontal acceleration of the sprinter?
- b.) If the force was exerted for 0.340 s, with what speed did the sprinter leave the starting block?

04. Two horses, on opposite sides of a canal, are pulling a boat through the canal via a rope tied from the boat to each horse. One horse is pulling with a force of 1200 N at angle of 40.0° with the direction of the boat's travel. If the other horse pulls with a force of 1000 N, what must be the direction of his pull if the boat moves parallel to the two sides of the canal? See the diagram to the right.

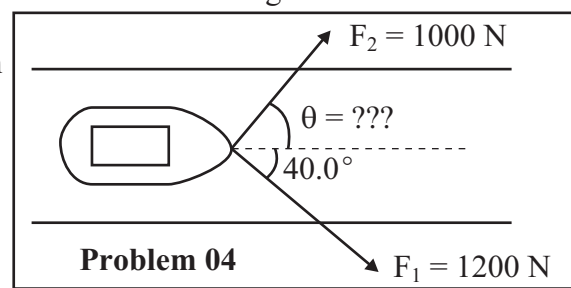

System of Objects

05. One paint bucket weighing 37.5 N (bucket I) is hanging by a massless cord from another paint bucket weighing 31.7 N (bucket II). The two are being pulled upward by a massless cord attached to the top bucket at 1.75 m/s^2 . Calculate the tension in each cord.

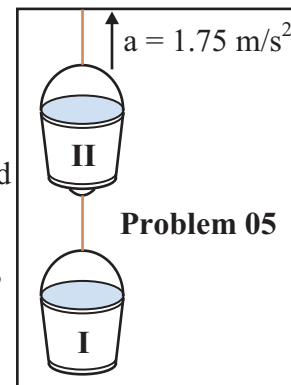

06. A 5350-kg helicopter accelerates upward at 0.625 m/s^2 while lifting a 1350-kg car attached by a cable.

- a.) What is the lift force exerted by the air on the rotors?
- b.) What is the tension in the cable (ignore its mass) that attaches the car to the helicopter?

07. A window washer pulls herself upward using a bucket-pulley apparatus. The mass of the window washer plus the bucket is 92.5 kg.

- a.) How hard must she pull downward to raise herself at a constant speed?
- b.) If she increases this force by 10 percent, what will her acceleration be?

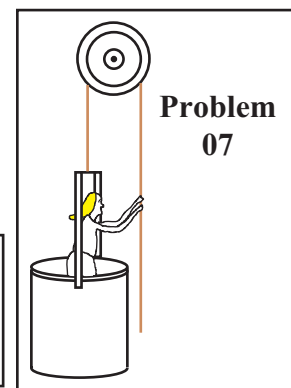

08. Three blocks on a frictionless horizontal surface are in contact with each other, as shown below. If a force \mathbf{F} is applied to block 1 (mass m_1). Determine _____.

- a.) the acceleration of the system (in terms of m_1 , m_2 , and m_3)
- b.) the net force on each block
- c.) the force that each block exerts on its neighbor
- d.) If $m_1 = 8.00 \text{ kg}$, $m_2 = 10.0 \text{ kg}$, $m_3 = 6.00 \text{ kg}$, and $\mathbf{F} = 100 \text{ N}$, give numerical answers to a.), b.), and c.).

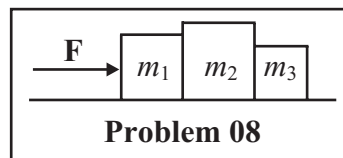

ANSWERS: 01. 5.89 m/s^2 02. a.) 53.0 N b.) 185 N c.) 86.4 N 03. a.) 3.93 m/s^2 b.) 1.34 m/s
 04. 50.5° 05. $F_{T1} = 44.2 \text{ N}$, $F_{T2} = 81.6 \text{ N}$ 06. a.) 69,848 N b.) 14,151 N 07. a.) 453 N b.) 0.98 m/s^2

Dynamics: Motion and Force

Newton's 2nd Law-2D Acceleration-Friction

Homework #22

Static Friction Causing Objects to Move

II

01. What is the maximum acceleration that a car can attain if the coefficient of static friction between the tires and the level ground is 0.80?
02. A flatbed truck is carrying a 61.7-kg sofa. If the coefficient of static friction between the feet of the sofa and the bed of the truck is 0.55, what is the maximum acceleration (or deceleration) the truck can undergo without the sofa sliding?
03. A magician pulls a table cloth off a table out from under a setting of plates and glasses. If the coefficient of static friction between the table settings and the table cloth is 0.67, what minimum acceleration must the magician give the table cloth as he pulls if the table settings are to remain in place?

Static and Kinetic Friction Opposing Objects' Motion

I

04. If the coefficient of kinetic friction between a 32.5-kg object and the floor is 0.20, what horizontal force is required to move the crate at a constant speed across the floor?
05. A 78.0 kg refrigerator has rubber feet. The coefficient of static friction between a floor and the feet has is 1.10, while its coefficient of kinetic friction is 0.90.
 - a.) What minimum force is needed to begin moving the refrigerator across the floor?
 - b.) Once the refrigerator begins moving, what minimum force is needed to keep it moving across the floor?

II

06. A man pushes an 58.5-kg sofa 2.30 m across a carpet with a horizontal force of 345 N. If coefficient of friction of 0.55, how long does it take the man to move sofa? (Assume it started from rest)
07. A man pushes a crate along a floor with a coefficient of friction of 0.48 until it reaches a speed of 6.25 m/s at which time the man stops pushing. How far across the floor will the crate slide after the man stops pushing?
08. A man wants to push a crate-framed box containing a 67.4-kg big screen television across a 32.3-m wide highway that has heavy traffic. He notices that the traffic light stays red, stopping the traffic, for 20.0 s. If the coefficient of kinetic friction between the road and the crate frame is 0.84, what minimum force must he apply to make it safely across the road before the traffic light turns green?

ANSWERS: **01.** 7.84 m/s^2 **02.** 5.39 m/s^2 **03.** 6.57 m/s^2 **04.** 63.7 N **05.** a.) 841 N b.) 688 N **06.** 3.01 s
07. 4.15 m **08.** 566 N

Dynamics: Motion and Force

Newton's 2nd Law-Inclined Planes

Homework #23

II

01. A 12.0-kg block, initially at rest, begins sliding 17.0 m down a 20.0° incline with negligible friction. See diagram to the right.
- Determine the acceleration of the block as it slides down the plane.
 - What will be the block's speed when it reaches the bottom of the incline?

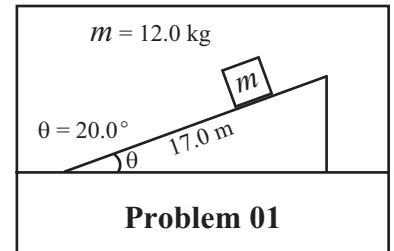

02. Repeat problem 05 if $\mu_k = 0.24$ between the block and the incline.

03. A block is given an initial speed of 12.50 m/s up a 35.0° incline with negligible friction.
- How far up the plane will it go?
 - How much time elapses before it returns to the starting point?

04. Repeat problem 07 if $\mu_k = 0.24$ between the block and the incline.

05. A man pushes a 39.0-kg crate, starting at rest, up a 30.0° incline that is 23.5 m long with a force of 335.0 N. The coefficient of sliding friction between the crate and the incline is 0.20. See diagram to the right.

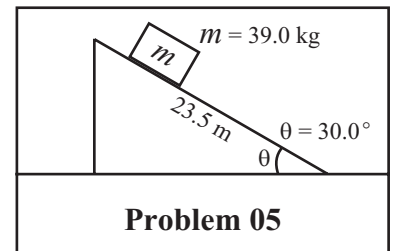

- What is the magnitude of the component of the force of gravity that tends to act parallel to the incline?
- What is the magnitude of the component of the force of gravity that tends to act perpendicular to the incline?
- What is the magnitude of the frictional force acting on the crate?
- What is the net force acting on the crate?
- What is the acceleration of the crate?
- What will be the speed of the crate when it reaches the top of the incline?

III

06. A 12.0-kg block lying on a 30.0° inclined plane is connected to a 15.0-kg block by a massless cord passing over a pulley as shown to the right. The coefficient of kinetic friction between the block and the inclined plane is 0.15.
- Determine the acceleration of the system.
 - Determine the tension in the cord joining the two masses.

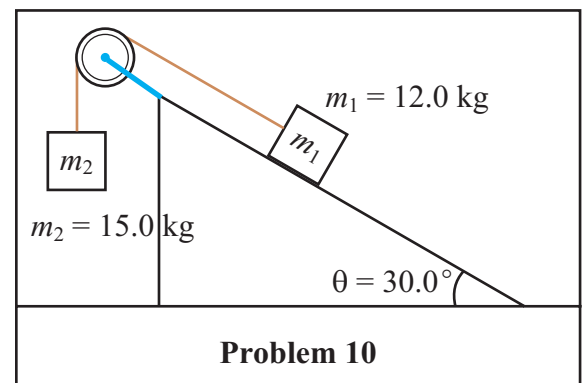

ANSWERS: **01.** a.) -3.35 m/s^2 b.) 10.7 m/s **02.** a.) -1.14 m/s^2 b.) -6.23 m/s **03.** a.) 13.9 m b.) 4.45 s
04. a.) 10.4 m b.) 4.03 s **05.** a.) 191 N b.) 331 N c.) 66.2 N d.) 77.8 N e.) 1.99 m/s^2 f.) 9.67 m/s
06. a.) 2.70 m/s^2 b.) 107 N

Dynamics: Motion and Force

Newton's 2nd Law-2D Equilibrium

Homework #24

II

01. A box with a mass of m sits on a 15.0° inclined plane as shown to the right. What is the minimum coefficient of static friction between the box and the inclined plane to keep the box from sliding down the incline?

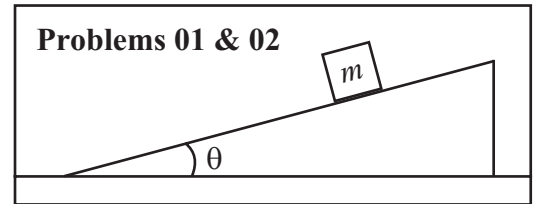

02. A box with a mass of m sits on an inclined plane as shown to the right. If the coefficient of static friction between the box and the inclined plane is 0.42, what is the maximum angle that the incline can be tilted before the box begins to slide?

03. An apparatus is set up, as in your lab, that resembles an old-fashioned street sign hanging from a city building as shown to the right. The meter stick is adjusted such that it makes a 90° angle with the ring stand. The following set of measurements were made: $\theta = 25.0^\circ$ and $m = 750$ g.
 a.) Calculate the tension, F_{T1} , in the lower string supporting the mass, m .
 b.) Calculate the tension, F_{T2} , in the string connecting the spring scale to the meter stick.

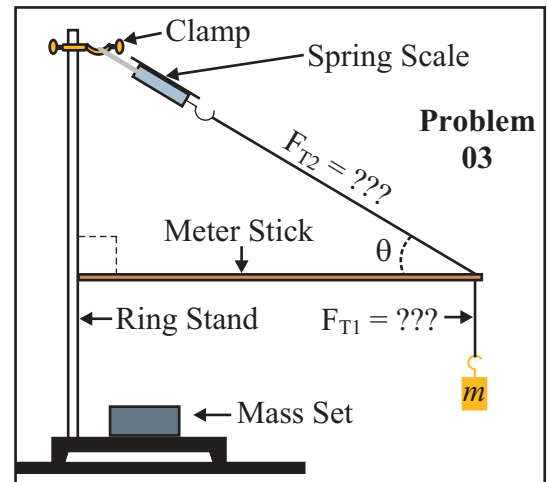

04. A car is traveling up a hill inclined at an average angle of 25.0° at a **CONSTANT** 40.0 km/h. If the friction of the mechanical moving parts of the car can be ignored, what is the minimum coefficient of static friction between the tires of the car and the road?

05. Three strings are tied together as shown to the right and placed on a lab table. A different mass is suspended from the free end of each of the three strings after the free ends are draped over pulleys as in the lab. Mass, m_2 , is 145 grams and mass, m_3 , is 210 grams. Angle α has a value of 65.0° and angle β has a value of 38.7° . What is the value of mass, m_1 , if the knot connecting the three strings is at equilibrium (rest)?

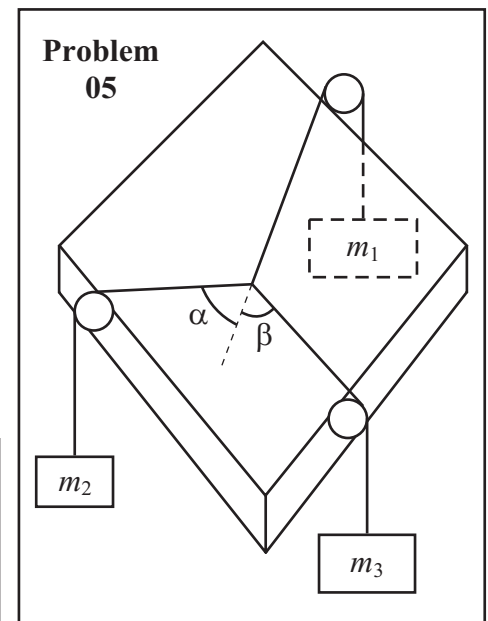

06. A 13.0-kg traffic light is tied to two supporting cables that are each attached to vertical poles as shown below. If the length of the one supporting cable is 11.806 m and the other is 7.461 m and the light hangs 0.786 m below the level of the supports, what is the tension in each supporting cable?

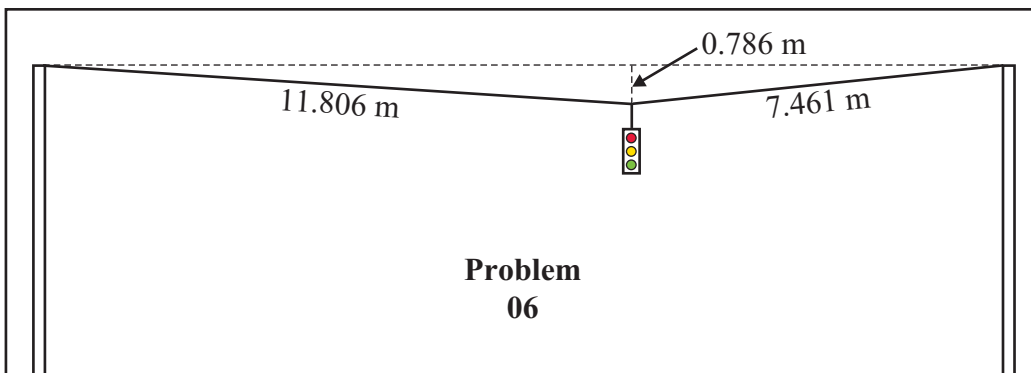

ANSWERS: 01. 0.268 02. 22.8° 03. a.) 7.35 N b.) 17.4 N 04. 0.47 05. 225 g 06. 757 N, 759 N

Dynamics: Motion and Force

Conceptual Review

Homework #25

01. Compare the effort (or force) needed to lift a 10-kg object when on the moon compared to being on the earth. Compare the force needed to throw a 2-kg object horizontally with a given speed when on the moon compared to being on the earth.
02. Why does a child in a wagon seem to fall backward when you give the wagon a sharp pull?
03. Whiplash sometimes results from an automobile accident when the victim's car is struck violently from the rear. Explain why the head of the victim seems to be thrown backward in this situation. Is it really?
04. When a golf ball is dropped to the pavement it bounces back up. Is a force needed to make it bounce back up? If so, what exerts the force?
05. A person wearing a cast on an arm or a leg experiences extra fatigue. Explain this on the basis of Newton's first and second laws.
06. If the acceleration of a body is zero, are no forces acting on it? Explain!!!
07. Why do you push harder on the pedals of a bicycle when first starting out then when moving at constant speed?
08. Only one force acts on an object. Can the object have zero acceleration? Can it have zero velocity?
09. When you are running and want to stop quickly, you must decelerate quickly. What is the origin of the force that causes you to stop?
10. In a log-rolling contest, when a contestant "walks" on a log floating in the water, does the log move in the opposite direction? How about if a person were walking along the length of the log in the water, does the log move? Explain!!!
11. Why might your foot hurt when you kick a football?
12. When you stand still on the ground, how large a force does the ground exert on you? Why doesn't this force make you rise up in the air?
13. The force of gravity on a 2-kg rock is twice as great as that on a 1-kg rock. Why then doesn't the heavier rock fall faster?
14. A person exerts an upward force of 40 N to hold onto a bag of groceries. Describe the "reaction" force (Newton's third law) by stating (a) its magnitude, (b) its direction, (c) *on* what body it is exerted, and (d) *by* what body it is exerted.
15. According to Newton's third law, each team in a tug-of-war pulls with equal force on the other team. What, then, determines which team will win?
16. Cross country skiers prefer their skis to have a large coefficient of static friction but a small coefficient of kinetic friction. Explain why.
17. When you brake your car very quickly, why is it safer if the wheels don't lock?
18. When driving on slick roads, why is it advisable to apply the brakes slowly?
19. Why is the stopping distance of a truck much shorter than for a train going the same speed?
20. Can a coefficient of friction exceed 1.0?
21. A block is given a push on a horizontal surface until it reaches a given speed. At this point, the force is removed (ignore friction) and the block moves at a constant speed until it encounters a ramp. It begins sliding up a ramp with sufficient friction that it can **NOT** be ignored. When the block reaches the highest point it slides back down. Why is its acceleration less on the descent than on the ascent?
22. A heavy crate rests on the bed of a flatbed truck. When the truck accelerates, the crate remains where it is on the truck, so it, too, accelerates. What force causes the crate to accelerate?

Circular Motion & Gravitation

Planetary Data

Homework #26

PLANETARY DATA

Planet	Mass (kg)	Mean Distance from Sun (m)	Radius (m)	Period (days)
Sun	1.99×10^{30}		6.970×10^8	
Mercury	3.30×10^{23}	5.791×10^{10}	2.439×10^6	87.97
Venus	4.87×10^{24}	1.082×10^{11}	6.052×10^6	224.70
Earth	5.98×10^{24}	1.496×10^{11}	6.378×10^6	365.26
Mars	6.42×10^{23}	2.279×10^{11}	3.398×10^6	686.98
Jupiter	1.90×10^{27}	7.783×10^{11}	7.149×10^7	4,332.71
Saturn	5.69×10^{26}	1.429×10^{12}	6.027×10^7	10,759.50
Uranus	8.69×10^{25}	2.870×10^{12}	2.556×10^7	30,685.00
Neptune	1.02×10^{26}	4.497×10^{12}	2.476×10^7	60,190.00
Pluto	1.32×10^{22}	5.900×10^{12}	1.160×10^6	90,550

NATURAL SATELLITES

Moon	Orbits	Mass (kg)	Mean Distance from Planet (m)	Radius (m)	Period (days)
Ganymede	Jupiter	1.48×10^{23}	1.070×10^9	2.631×10^6	7.15
Callisto	Jupiter	1.08×10^{23}	1.883×10^9	2.400×10^6	16.69
Io	Jupiter	8.93×10^{22}	4.22×10^8	1.815×10^6	1.77
Europa	Jupiter	4.80×10^{22}	6.71×10^8	1.569×10^6	3.55
Titan	Saturn	1.35×10^{23}	1.222×10^9	2.575×10^6	15.95
Triton	Neptune	2.14×10^{22}	3.55×10^8	1.353×10^6	-5.88
Moon	Earth	7.35×10^{22}	3.84×10^8	1.738×10^6	27.32

Circular Motion & Gravitation

Centripetal Acceleration

Homework #27

II

01. A car traveling at 80.0 km/h rounds a circular curve of radius 95.0 m. What is the car's centripetal acceleration?
02. A ball in a roulette wheel makes 85 revolutions in 45.0 s before falling. If the radius of the wheel is 57.5 cm, what is the average centripetal acceleration of the ball?
03. If a coin is placed 5.00 cm from the center of a 45 rpm record, what is the centripetal acceleration of the coin when the record reaches its rated speed?
04. A bicycle tire is making 12.5 revolutions per minute. If the diameter of the tire is 68.0 cm, what centripetal acceleration of a point on the edge of the tire?
05. A car tachometer indicates the flywheel is spinning at 2200 rpm. The flywheel is 35.0 cm in diameter.
 - a.) what is the centripetal acceleration of a point on the edge of the wheel?
 - b.) what is the centripetal acceleration of a point on the wheel that is halfway between the center and the edge of the wheel?
06. A jet plane traveling at 1800 km/h pulls out of a dive by moving in an arc of radius 4.00 km. What is the plane's acceleration in g's?
07. A child on a merry-go-round experiences a centripetal acceleration of 5.25 m/s^2 . The wooden horse on which the child sits is 6.25 m from the center of the rotating disk.
 - a.) What is the linear speed of the child?
 - b.) What is the frequency (in rpm's) of the child?
08. Calculate the centripetal acceleration of the earth in its orbit around the sun. Assume the earth's orbit is a circle with a radius of $1.50 \times 10^{11} \text{ m}$.
09. The hammer throw is an Olympic sport in which the contestant twirls a steel cord attached to a "weight" (mass) called the hammer and releases the cord so the hammer is "thrown" across a field. The length of the hammer is 1.195-1.215 m and the mass is 7.256 kg while the diameter of the head is 11 cm. The throwing circle is 2.135m in diameter. If the cord is swung in a radius of 2.65 m and the hammer experiences a final centripetal acceleration of 211 m/s^2 , what is the frequency (rpm's) of the contestant as he releases the hammer?
10. One aspect of training for an astronaut involves experiencing and enduring extreme accelerations. To achieve this a device that rotates in a circle was designed. The astronaut is strapped into a chair in a spherical chamber. This chamber is attached to a motor in the center of the room by a metallic, multiple-poled structure I will call the arm. If the arm is 4.50 m long and the astronaut is to experience an acceleration of $5g$'s, calculate the following.
 - a.) What is the linear speed of the spherical chamber?
 - b.) What frequency (in rpm's) must the motor generate to achieve this acceleration?

ANSWERS: **01.** 5.21 m/s^2 **02.** 81.0 m/s^2 **03.** 1.11 m/s^2 **04.** 0.582 m/s^2
05. a.) $9.29 \times 10^3 \text{ m/s}^2$ b.) $4.64 \times 10^3 \text{ m/s}^2$ **06.** $6.39g$'s **07.** a.) 5.73 m/s b.) 8.75 rpm **08.** $5.95 \times 10^{-3} \text{ m/s}^2$
09. 85.2 rpm's **10.** a.) 14.8 m/s b.) 31.5 rpm's

Circular Motion & Gravitation

Centripetal Dynamics

Homework #28

I

01. A 6.35-kg object is twirled in a circle of radius 18.3 m at a speed of 12.5 m/s. What is the centripetal force?
02. A 1.35-kg ball in a roulette wheel makes 85 revolutions in 45.0 s before falling. If the radius of the roulette wheel is 57.5 cm, what is the average centripetal force on the ball of the ball?

II-Horizontal Circular Motion

03. A 0.453-kg ball attached to the end of a cord is rotated in a circle with a radius of 1.25 m on a frictionless horizontal surface. If the cord will break when the tension in it exceeds 57.5 N, what is the maximum speed the ball can have?
04. A 1250-kg car traveling at 40.0 km/h rounds a flat curve of radius 87.5 m. What is the minimum coefficient of friction between the tires and the road surface that is necessary to make this turn?
05. A coin is placed 11.5 cm from the axis of a rotating turntable of variable speed. The speed of the turntable is slowly increased. The coin remains fixed at the same location on the turntable until it reaches a rate of 38.5 rpm, at which point the coin slides off. What is the coefficient of friction between the coin and the turntable?
06. On an icy day a car approaches a flat curve with a radius of 68.2 m. If the coefficient of friction between the tires and ice is 0.13, what is the maximum speed that the car should make the turn?

07. In a "Rotor-ride" at a carnival, riders are pressed against the inside wall of a vertical cylinder 2.50 m in radius rotating at 0.40 revolutions per second when the floor drops out. What minimum coefficient of friction is needed so a person won't slip down?

II-Vertical Circular Motion

08. A roller coaster enters a vertical circle with a radius of curvature of 9.25 m.
a.) What is the minimum speed must the roller coaster be moving at the top so the passengers do not fall out?
b.) Assuming uniform circular motion, what is the force the tracks experience at the bottom (mass = 2000 kg)?
09. A ball is tied to the end of a string that is 1.65 m long and is rotated in a vertical circle at a constant speed.
a.) What is the minimum speed needed to maintain this circular motion throughout the path?
b.) If the ball has a mass of 0.375 kg, what is the maximum tension in the string?
10. A 0.335-kg ball is cleverly rotated at a uniform rate of 3.25 m/s in a vertical circle of radius 82.5 cm.
a.) Calculate the tension in the string when the ball is at the top of its path.
b.) Calculate the tension in the string when the ball is at the bottom of its path.

III-Banked Curves

11. A curve, with a radius of 60.0m, is to be constructed for a car traveling 60.0 km/h.
a.) What angle is needed for proper banking?
b.) What minimum coefficient of friction is needed if a car were round this curve, once constructed, at 90.0 km/h?
12. What must be the coefficient of static friction for a car rounding a curve of radius 68.6 m at 92.3 km/h if it is properly banked for 55.0 km/h?

ANSWERS: 01. 54.2 N 02. 109 N 03. 12.6 m/s 04. 0.14 05. 0.19 06. 9.32 m/s 07. 0.62
08. a.) 9.52 m/s b.) 39,200 N 09. a.) 4.02 m/s b.) 7.35 N 10. a.) 1.01 N b.) 7.57 N
11. a.) 25.3° b.) 0.39 12. 0.47 (Angle = 19.1°)

Circular Motion & Gravitation

Universal Gravitation

Homework #29

I

01. Calculate the gravitational force between a 55.3-kg woman and a 87.5-kg man if they are _____.
a.) 20.0 m apart b.) 0.300 m apart (from center to center)
02. What is the force of gravity on a 1250-kg spacecraft that is two earth radii **ABOVE** the earth's surface?
03. Calculate the acceleration due to gravity on _____.
a.) Jupiter b.) the moon
04. Calculate the acceleration due to gravity on _____, a moon of Jupiter.
a.) Io b.) Europa
05. A hypothetical planet has the same radius as earth but a mass that $2\frac{1}{2}$ that of earth. Calculate the acceleration due to gravity on this planet.
06. A hypothetical planet has the same mass as earth but a radius that $2\frac{1}{2}$ that of earth. Calculate the acceleration due to gravity on this planet.

II

07. A hypothetical planet has a mass 100 times that of earth and a radius 20 times that of earth. Calculate the acceleration due to gravity on this planet's surface.
08. What is the distance from the earth's center to a point outside the earth where the gravitational acceleration due to earth is $\frac{1}{25}$ that of its value at the earth's surface?
09. At the surface of a certain planet, the acceleration due to gravity is 2.0 m/s^2 . A 5.0 kg copper ball is transported to this planet. Find _____.
a.) the mass of the ball on earth b.) the mass of the ball on this planet
c.) the weight of the ball on earth d.) the weight of the ball on this planet
10. Calculate the value of the acceleration due to gravity at _____.
a.) 3200 m above the earth's surface b.) 3200 km above the earth's surface
11. Given the acceleration due to gravity at the surface of Mars is 0.378 that of earth and Mars' radius is 3400 km, determine the mass of Mars.

III

12. Four 6.00-kg balls are placed at the corners of a rectangle of dimensions 0.800 m x 1.200 m. Calculate the force of gravity on one sphere due to the other three.
13. If the mass of the earth were doubled, but it kept the same density and spherical shape. How would the weight of an object change at the earth's surface?

ANSWERS: **01.** a.) $8.07 \times 10^{-10} \text{ N}$ b.) $3.59 \times 10^{-6} \text{ N}$ **02.** 1361 N **03.** a.) 24.8 m/s^2 b.) 1.62 m/s^2
04. a.) 1.81 m/s^2 b.) 1.30 m/s^2 **05.** 24.5 m/s^2 **06.** 1.57 m/s^2 **07.** 2.45 m/s^2 **08.** $3.19 \times 10^7 \text{ m}$
09. a.) 5.0 kg b.) 5.0 kg c.) 49 N d.) 10 N **10.** a.) 9.79 m/s^2 b.) 4.35 m/s^2 **11.** $6.42 \times 10^{23} \text{ kg}$
12. $5.26 \times 10^{-9} \text{ kg}$ (Angle = 26.1°) **13.** Every object would have weight approximately 1.26 times on earth now

Circular Motion & Gravitation

Satellite Motion & Apparent Weightlessness

Homework #30

I

01. What is the apparent weight of a 52.5-kg woman in an elevator that moves _____?
a.) with a constant upward speed of 6.50 m/s
b.) with a constant downward speed of 6.50 m/s?
c.) with an upward acceleration of $\frac{1}{4}g$
d.) with an downward acceleration of $\frac{1}{4}g$
02. What is the _____ of a satellite that is 3200 km above the earth's surface?
a.) speed b.) period
03. What is the _____ of a satellite that is 3200 km above the Callisto's surface? (Callisto is a moon of Jupiter)
a.) speed b.) period

II

04. A 112.5-kg businessman carries a 4.25-kg briefcase onto an elevator. The elevator begins to move causing the briefcase to have an apparent weight of 35.0 N.
a.) What is the acceleration of the elevator? b.) What force does the floor feel at that moment?
c.) What is the net force acting on the businessman
05. A satellite is to be placed in an orbit such that it is to remain over the same geographical point on the equator of the earth.
a.) What must be the height of this satellite above the earth's surface?
b.) What must be the velocity of this satellite?
06. What is the apparent weight of an 82.5-kg astronaut 3800 km from the center of the earth's moon in a space vehicle moving at _____ toward the moon's surface? (Include magnitude and direction)
a.) constant velocity of 125 m/s
b.) accelerating toward the moon at 0.0750 m/s^2
c.) accelerating toward the moon at 3.25 m/s^2
07. A space station is designed so that astronauts can enjoy long-term residence of several months or years. To simulate gravity, the space station would be a large circular tube (like a bicycle tire) with a diameter of 200 m.
a.) What part of the structure would people walk?
b.) With what linear speed would the space station have to be rotating to exactly simulate gravity here on earth?
c.) Studies show that making more than two rpm's causes dizziness and nausea. How could the space station be redesigned so that astronauts can live comfortably while still experiencing earth-like gravitational simulation?
08. A roller coaster goes into a vertical circle of diameter 18.5 m and takes 5.25 s to complete the loop. Assuming uniform circular motion, calculate the ratio of a person's apparent weight to their actual weight when they are at the _____.
a.) top b.) bottom

ANSWERS: **01.** a.) 515 N b.) 515 N c.) 643 N d.) 386 N **02.** a.) 6453 m/s b.) 2.59 h (9328 s)
03. a.) 1134 m/s b.) 8.62 h (31,023 s) **04.** a.) -1.56 m/s^2 b.) 962 N c.) -176 N
05. a.) $3.59 \times 10^7 \text{ m}$ b.) $3.07 \times 10^3 \text{ m/s}$ **06.** a.) 28.0 N b.) 21.8 N c.) -240 N
07. a.) on the inside of the outermost wall of the tube b.) 31.3 m/s c.) Diameter > 447 m
08. a.) 0.352 (this is not a safe roller coaster) b.) 2.35

Circular Motion & Gravitation

Kepler's Laws

Homework #31

I

01. Calculate the length of a Venusian year. Show work!!!
02. What is the period of a satellite of Jupiter that is orbiting 5.65×10^7 m from its center? Show work!!!
03. What is the radius of orbit of a satellite of Saturn if it takes 6.25 days to complete an orbit? Show work!!!
04. Calculate the length of a Neptunian year. Show work!!!
05. Calculate the period of a communications satellite of the earth that is at an altitude of 3200 km. Show work!!!
06. What is the altitude of a satellite that remain over the same geographical point on the equator of the earth. Show work!!!
07. How old would you be on Pluto? Show work!!! (Answer on bottom assumes an age of 17 earth years)
08. How far is Mercury from the sun? Show work!!!

ANSWERS: **01.** 225 days (0.615 yrs) **02.** 2.08 h (0.0867 days) **03.** 6.54×10^8 m **04.** 165 yrs
05. 2.58 hrs (0.108 days) **06.** 3.60×10^7 m **07.** 25.0 days old (0.0685 yrs) **08.** 5.79×10^{10} m

Circular Motion & Gravitation

Conceptual Review

Homework #32

01. It is sometimes said that water is removed from clothes in a spin dryer by centrifugal force throwing the water outward. Is this correct? Explain!!!
02. Will the acceleration of a car be the same when it travels around a sharp curve at 60 km/h as when it travels around a gentle curve at the same speed? Explain!!!
03. Suppose a car moves at a constant speed along a mountain road. At what place does it exert the greatest and least forces on the road: (a) at the top of the hill, (b) at a dip between two hills, (c) on a level stretch near the bottom of the hill. Explain!!!
04. Describe all the forces acting on a child on a merry-go round.
05. A bucket of water can be whirled in a vertical circle without the water spilling out even at the top of the circle when the bucket is upside down. Explain!!!
06. Does an apple exert a gravitational force on the earth? If so, how large a force? Consider an apple (a) attached to a tree, and (b) falling. Explain!!!
07. If the earth's mass were suddenly to double, in what ways would the moon's orbit change? Explain!!!
08. Describe how careful measurements of the variation of g in the vicinity of an ore deposit might be used to estimate the amount of ore present.
09. When will your apparent weight be greatest, as measured by a scale in a moving elevator: when the elevator (a) accelerates downward, (b) accelerates upward, (c) is in freefall, (d) moves upward at a constant speed? In which cases would your apparent weight be the least? When would it be the same as when you are on the ground? Explain!!!
10. The sun is directly below us at midnight, in line with the earth's center. Are we then heavier at midnight due to the sun's gravitational force on us than at noon? Explain!!!
11. If you were in a satellite orbiting the earth, how might you cope with walking, drinking or putting a pen on a table?
12. An antenna loosens and becomes detached from a satellite in a circular orbit around the earth. Describe the antenna's motion subsequently. If it will land on the earth, describe where; if not, describe how it could be made land on the earth.
13. Astronauts who spend long periods in outer space could be adversely affected by weightlessness. One way to simulate gravity is to shape the space station like a bicycle wheel that rotates, with the astronauts walking on the inside of the "tire." Explain how this simulates gravity. Consider (a) how objects fall, (b) the force we feel on our feet, and (c) any other aspects of gravity of which you can think.
14. People sometimes ask, "What keeps a satellite up in its orbit around the earth?" How would you respond?
15. Explain why a person running experiences "freefall" or "apparent weightlessness" between steps.
16. The sun's gravitational pull on the earth is much larger than the moon's. Yet the moon is mainly responsible for tides. Explain!!!
17. The earth moves faster in its orbit around the sun in winter than in summer. Is it closer to the sun in the summer or winter? Does this affect the season's? Explain!!!

Work, Energy, Power, & Simple Machines

Work-Constant Force

Homework #33

I

01. How much work is done when a 3.25-kg book is _____ at constant speed for a distance of 2.25 m?
a.) lifted vertically b.) pushed across a floor with a frictional force of 6.45 N
c.) pushed across a floor with a coefficient of friction of 0.22
02. A boy pulls with a 92.5-N force on the handle of a 27.5 kg wagon while the handle makes an angle of 35.0° . If friction is negligible, and the boy pulls the wagon around the block a total distance of 215.6 m, how much work has the boy done?
03. how much work did a horse do that pulled a 225-kg wagon 52.5 km without acceleration with an effective coefficient of friction of 0.060?
04. A car does 7.25×10^4 J of work in traveling 2.35 km at a constant speed. What was the average force of friction (from all sources) acting on the car?
05. How far must a 212-kg pile driver fall if it is capable of doing 12,500 J of work?
06. What minimum work is done in pushing a 65.0-kg crate up a 25.0° incline with negligible friction that is 11.0 m long? See diagram to the right and below.

II

07. A 277.6-kg piano slides down an 11.0-m long ramp that makes a 25.0° angle and is kept from accelerating by a man pushing up along the incline (see diagram to the right). The effective coefficient of friction is 0.42. What is the minimum work done by the man on the piano when he reaches the second floor?

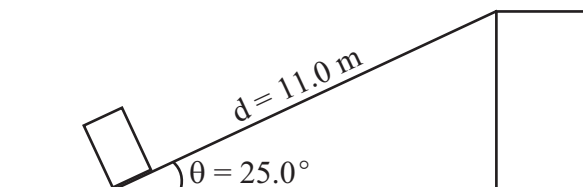

Problems 06, 07, & 08

08. A man pushes a 112.8-kg washing machine up a 11.0-m long ramp that makes a 25.0° angle with the ground to get it to the second floor for his wife as a Valentine's gift (see diagram above). He pushes with a force of 840 N parallel to the incline. The coefficient of sliding friction between the ramp and the washing machine is 0.24.
- a.) How much work was done by the man in reaching the second floor?
b.) How much work was done by the gravity when the dryer reached the second floor?
c.) How much work was done by the friction when the dryer reached the second floor?
d.) What was the **NET** work done on the dryer when it reached the second floor?

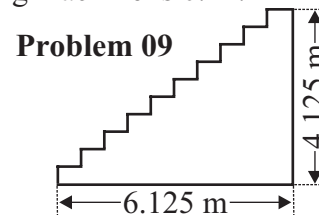

Problem 09

09. A woman walks a flight of stairs 4.125 m high and 6.125 m in breadth carrying a 38.6-N bag of groceries. What is the minimum work done by the woman on the bag of groceries? See diagram above.
10. In pedaling a bicycle, a particular cyclist exerts a downward force of 82.5 N during each stroke. If the diameter of the circle traced by each pedal is 36.6 cm, calculate how much work is done during each stroke.
11. Eight bricks, each 6.00 cm thick with a mass of 1.25 kg, lie on a flat table. What minimum work is required to stack them one on top of another?

ANSWERS: 01. a.) 71.7 J b.) 14.5 J c.) 15.8 J 02. 16,336 J 03. 6.95×10^3 kJ 04. 30.9 N 05. 6.02 m
06. 2961 J 07. -1256 J 08. a.) 9240 J b.) -5139 J c.) -2645 J d.) 1456 J 09. 159 J 10. 30.2 J 11. 20.6 J

Work, Energy, Power, & Simple Machines

Work-Varying Force

Homework #34

II

01. Use the graph to the right to estimate the work done in moving a 5.65-kg object from 6.0 m to 30.0 m. Use at least five intervals.
02. Use the graph to the right to estimate the work done in moving a 12.6-kg object from 0.0 m to 40.0 m. Use at least five intervals.

Problems 01 & 02

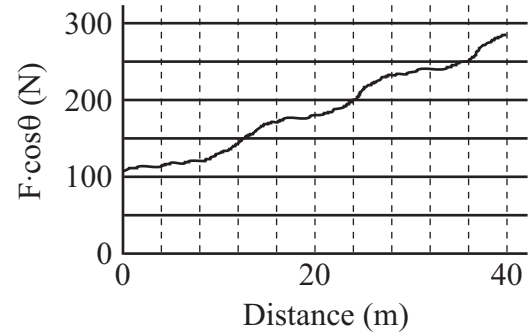

03. Use the graph to the right to answer the following.
- Estimate the work done for the first 3.0 m.
 - Estimate the work done for the first 10.0 m.
 - Estimate the work done for the first 11.5 m.
 - Estimate the work done for the first 15.0 m.

Problem 03

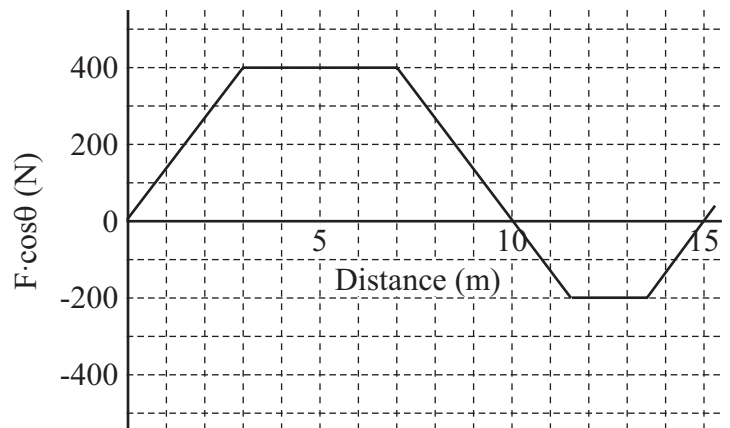

III

04. A 1000-kg space vehicle falls vertically from a height of 3000 km above the earth's surface. Determine, approximately, how much work is done by the force of gravity in bringing the vehicle to the earth's surface. (Use the graph to the right to construct an $F \cdot \cos\theta$ -vs- r graph, where r is the distance from the earth's center. Then determine the work graphically.)

Problem 04

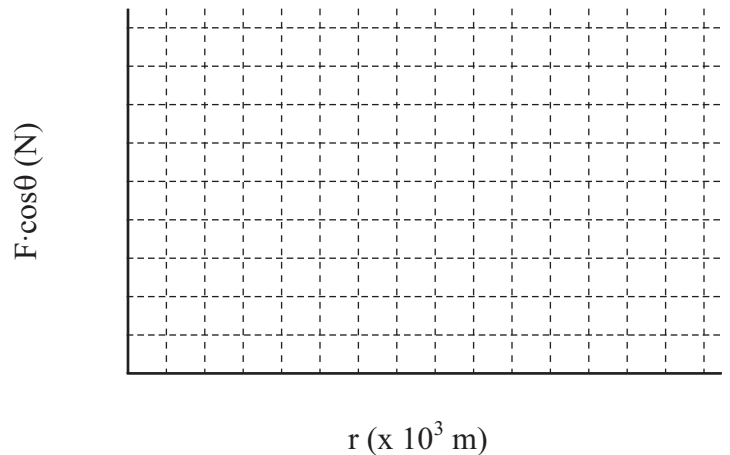

ANSWERS: 01. 4230 J 02. 7428 J 03. a.) 600 J b.) 2800 J c.) 2650 J d.) 2100 J 04. 2.00×10^{10} J

Work, Energy, Power, & Simple Machines

Kinetic Energy & the Work-Energy Theorem

Homework #35

I

01. What is the initial KE of a 0.450 mg flea that leaves the ground at 27.5 cm/s?
02. An electron ($m_e = 9.11 \times 10^{-31}$ kg) has 30.0 eV ($1 \text{ eV} = 1.6 \times 10^{-19}$ J) of energy. How fast is it moving?
03. If the KE of a particle is doubled, by what factor has its speed increased?
04. If the speed of a particle is doubled, by what factor has its KE increased?
05. How much work does it take to accelerate an electron ($m = 9.11 \times 10^{-31}$ kg) from rest to 8.00×10^5 m/s?
06. How much work must be done to stop a 1250-kg car traveling at 90.0 km/h?

II

07. A 140-g baseball traveling 31.6 m/s moves a fielder's glove backward 14.7 cm when the ball is caught. What was the average force exerted by the ball on the glove?
08. If the speed of a car is increased by 50.0%, by what factor will its minimum braking distance be increased assuming all else is the same? Ignore the driver's reaction time.
09. In 1955 a paratrooper fell 370 m after jumping from an aircraft without his parachute opening. He landed in a snowbank, creating a crater 1.1 m deep, but survived with only minor injuries. Assuming the paratrooper's mass was 80 kg and his terminal velocity was 50 m/s, estimate _____.
 - a.) the work done by the snow
 - b.) the average force exerted on him by the snow to stop him
 - c.) the work done on him by air resistance as he fell
10. A 230-kg load is lifted 18.0 m vertically upward with an acceleration of $a = 0.180g$ by a single cable. Determine _____.
 - a.) the tension in the cable
 - b.) the net work done on the load
 - c.) the work done by the cable on the load
 - d.) the work done by gravity on the load
 - e.) the final speed of the load assuming it started from rest.

III

11. Car A has twice the mass of car B, but only half as much KE. When both cars increase their speed by 5.0 m/s, they have the same KE. What were the original speeds of the two cars?

ANSWERS: **01.** 1.70×10^{-8} J **02.** 3.25×10^6 m/s **03.** $2^{\frac{1}{2}} = \sqrt{2}$ **04.** 4 **05.** 2.92×10^{-19} J **06.** 3.91×10^5 J
07. 476 N **08.** $(1.5)^2 = 2.25$ **09.** a.) -1.0×10^5 J b.) 9.1×10^4 N c.) -1.9×10^5 J
10. a.) 2660 N b.) 7303 J c.) 4.79×10^4 J d.) -4.06×10^4 J e.) 7.97 m/s **11.** $v_A = 3.54$ m/s, $v_B = 7.07$ m/s

Work, Energy, Power, & Simple Machines

Potential Energy

Homework #36

I

01. A spring has a spring constant, k , of 4350 N/m. How much must this spring be compressed to store 15.0 J?
02. A 4.45 kg monkey swings from one branch to another 1.25 m higher. What is the change in potential energy?

II

03. A 1.85-m tall person lifts a 345-g book so it is 2.32 m off the ground.
- What is the potential energy of the book relative to the ground?
 - What is the potential energy of the book relative to the top of the person's head?
 - How is the work done by the person to lift the book affected by the answers in parts a.) and b.)?
04. A 76.4-kg hiker starts at an elevation of 1440 m and climbs to the top of a 3280-m peak.
- What is the hiker's change in potential energy?
 - What is the minimum work required of the hiker?
 - Can the actual work done be more than the answer to part b.)? Explain!!!
05. A 350-g mass is hung from a 32.50-cm long vertical spring causing its length to increase to 41.75 cm.
- What is the spring constant of this spring?
 - What is the elastic potential energy of the system after the mass has stretched the spring?
 - What is the change in gravitational potential energy of the system after the mass has stretched the spring?
 - What is the change in total potential energy of the system after the mass has stretched the spring?
- For parts e.) through g.) assume someone pulls the mass down, stretching the spring an additional 9.25 cm and releases the mass. Answers to parts e.) through g.) are in relation to the original unstretched spring and refer to the instant the spring is released.**
- What is the elastic potential energy of the system after the mass has stretched the spring?
 - What is the change in gravitational potential energy of the system after the mass has stretched the spring?
 - What is the change in total potential energy of the system after the mass has stretched the spring?

ANSWERS: **01.** 8.30 cm **02.** 54.5 J **03.** a.) 7.84 J b.) 1.59 J c.) it's the same (7.84 J)
04. a.) 1.38×10^6 J b.) 1.38×10^6 J c.) Yes, if the hiker has an average acceleration during the trip.
05. a.) 37.1 N/m b.) 0.159 J c.) -0.317 J d.) -0.159 J e.) 0.635 J f.) -0.635 J g.) 0 J

Work, Energy, Power, & Simple Machines

The Law of Conservation of Energy

Homework #37

I

01. A box slides down a frictionless incline that is 15.0 m high. If it starts from rest at the top of the incline, what will be the speed of the box when it reaches the bottom?
02. Tarzan, running 5.85 m/s, grabs a vine hanging from a branch of a tall tree. How high can he swing?
03. A dart gun has a spring with a spring constant of 297.5 N/m. A 35.0-g dart depresses the spring 6.50 cm and is locked into place until the trigger releases it. The gun is pointed horizontally and the trigger is pulled. What will be the speed of the dart as it leaves the gun?
04. A ball is thrown straight up by a person standing in a foxhole such that it leaves the person's hand at 68.4 m/s just as the hand is level with the ground. How high will the ball go?
05. A rock is dropped from a cliff that is 238.7 m above the ground. With what speed will the rock hit the ground?

II

06. The bumper of a 1200-kg car has two springs, each with a spring constant of 8250 N/m. This car is pulling into a parking space and goes too far, running into the wall of a building. If the bumper depresses 7.25 cm as a result of the collision, how fast was the car going when it hit the wall. Ignore any losses of energy to dissipative forces.
07. An arrow is fired from a bow with a speed of 27.5 m/s at an unknown angle from the top of a 65.0-m high cliff. What will be its speed as it hits the ground below?
08. A ski is sliding along the snow-covered ground at 23.7 m/s when it encounters an incline. Ignore friction throughout the problem.
 - a.) How high will the ski go?
 - b.) If the incline is at angle of a 25.0° , how far along the incline will ski roll?

09. A 5.75-kg mass is hung from a vertical spring causing it to stretch 23.6 cm.
 - a.) What is the elastic potential energy of the system?
 - b.) What is the change in gravitational potential energy of the system?
 - c.) What is the total change in potential energy of the system?
10. The high jump is a track event in which the KE of the athlete is converted to GPE without the aid of a pole. With what minimum speed must a high jumper leave the ground if he is to raise his center of mass 1.92 m and cross the bar with a horizontal velocity of 0.875 m/s?
11. A dart gun has a spring with a spring constant of 297.5 N/m. A 35.0-g dart depresses the spring 6.50 cm and is locked into place until the trigger releases it. The gun is pointed vertically and the trigger is pulled. How high above the barrel of the gun will the dart go?

III

12. A 3.65-kg mass falls 75.0 cm before striking the top of a vertical spring with a stiffness constant of 975 N/m. How far will the spring compress? The 75.0-cm fall occurs before the mass depresses the spring. See diagram shown to the right.

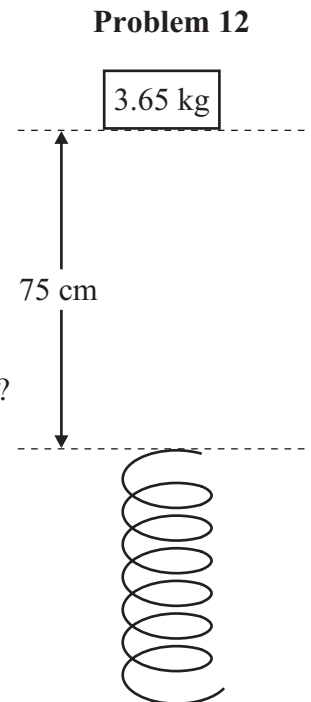

ANSWERS: **01.** 17.1 m/s **02.** 1.75 m **03.** 5.99 m/s **04.** 238.7 m **05.** 68.4 m/s **06.** 0.269 m/s **07.** 45.1 m/s
08. a.) 28.7 m b.) 67.8 m **09.** a.) 6.65 J b.) -13.3 J c.) -6.65 J **10.** 6.20 m/s **11.** 1.76 m **12.** 27.4 cm

Work, Energy, Power, & Simple Machines

Thermal Energy & Energy Conservation

Homework #38

I

01. A 170.0-g hockey puck is given a push from a hockey stick such that it leaves contact with the stick traveling at 12.25 m/s and slides 84.6 m.
- How much thermal energy is produced?
 - What is the coefficient of kinetic friction between the puck and the ice?

II

02. A 32.6-kg child, starting from rest, slides down 30.0°-slide that is 2.15 m high.
- If thermal losses are ignored, what will the speed of the child be at the bottom?
For parts b.) and c.), assume the speed of the child at the bottom of the incline was actually 5.00 m/s.
 - How much thermal energy was produced during the ride?
 - What is the coefficient of kinetic friction between the slide and the child's clothing?
03. A 39.5-kg crate, starting from rest, is pulled across a large room with a constant force of 70.0 N. For the first 8.00 m the floor is essentially frictionless. The next 9.00 m is carpeted creating a coefficient of friction of 0.28. What is the final speed of the crate?
04. Two identical railroad cars, each of mass 6400 kg, and traveling at identical speeds of 95.0 km/h are on the same track heading in opposite directions toward each other. They collide head on bringing both cars to rest. How much thermal energy is generated in this collision?

05. A ski, starting from rest, slides down a 12.5-m high slope that is angled at 60.0°. If the coefficient of kinetic friction between the ski and the snow is 0.07, how far will the ski slide across the level snow **AFTER** reaching the bottom of the slope _____?
- if friction along the slope is ignored
 - if friction along the slope is included in calculations
 - Why are the answers to parts a.) and b.) so close in magnitude?
06. A crate falls of the back of a pickup truck, from a height of 1.05 m, when it is traveling 65.0 km/h. If the coefficient of kinetic friction between the crate and the road surface is 0.60, how far will the crate slide?

III

07. A 7.50-kg box is attached to a horizontal spring whose other end is attached to the wall as shown below. The box can slide along the floor where the coefficient of friction is 0.35. A force of 85.0 N is applied to the box so as to compress the spring 22.0 cm. If the force compressing the spring is removed, how far beyond the equilibrium position will the spring stretch on its first swing?



ANSWERS: **01.** a.) 12.8 J b.) 0.09 **02.** a.) 6.49 m/s b.) 279 J c.) 0.23 **03.** 3.30 m/s
04. 4.46×10^6 J **05.** a.) 179 m b.) 171 m **06.** 29.5 m **07.** 8.68 cm

Work, Energy, Power, & Simple Machines

Power

Homework #39

I

- A motor with a rating of 25,000 W is used to wind the supporting cable of an elevator that has a mass of 1850 kg when empty.
 - How long will it take the empty elevator to go from the first to fifth floor which is 15.0 m above the ground?
 - How long will it take this elevator to go from the first to fifth floor with three people on board with masses of 45.0 kg, 62.5 kg, and 81.6 kg?
- What is the average force exerted on a car from friction and air resistance if the car generates 12.5 hp when traveling at a constant 85.0 km/h?
- Power companies send itemized bills each month to your home expressing the amount of electrical energy consumed by the household during the previous month. This energy is expressed as kilowatt-hours. How much energy is one kilowatt-hour expressed in metric units?
- How much work can a 1.5 hp motor do in 20 minutes?
- If a $\frac{1}{2}$ -hp garage door opener lifts a 7.00-ft door in 12.0 s, what is the average force being applied against gravity and friction? (1 foot = 30.5 cm)

II

- What power rating should a motor have if it is to pump 5.65 kg of water per minute to a height of 2.70 m?
- A 1250-kg car slows down from 80.0 km/h to 60.0 km/h in 6.0 s when on a level stretch of road.
 - What power is needed to keep the car traveling at a constant 70.0 km/h on this level stretch of road?
 - What power is needed to keep the car traveling at a constant 70.0 km/h up a 15.0° -incline? Assume the same force of friction as part a.)
- What **AVERAGE** power was developed by the brakes of a 1350-kg car in bringing a car traveling 20.0 km/h to a halt over a distance of 60.0 m?
- A 1425-kg car is advertised to have 150 hp under the hood. What is the steepest angle of a hill it climb at a constant 50.0 km/h if the force of friction and air resistance total 600 N?
- What average power is created by a shotputter in bringing a 7.27-kg shot from rest to 16.5 m/s in 1.85 s?
- A cyclist coasts down 7.50° -hill at a constant 8.50 m/s. The cyclist and his bicycle have a total mass of 82.6 kg.
 - What must be the cyclist's power output to go up the same hill at the same speed?
 - If the pedals rotate once every 0.285 s in a circle with a diameter of 18.0 cm what must be the average force applied to the pedals during each downward stroke to go up this hill at this speed?

III

- A small, above-ground pool with a diameter of 18.00 feet (1 foot = 30.5 cm) is filled to a height of 4.00 feet. How long would it theoretically take to circulate all of the water of the pool through a pump with a $\frac{1}{2}$ -hp rating and a $\frac{3}{4}$ -inch (1 inch = 2.54 cm) diameter hose? Assume the average force on the water by the pump is 40.0 N.

ANSWERS: **01.** a.) 10.9 s b.) 12.0 s **02.** 397 N **03.** 3.60×10^6 J **04.** 1.35×10^6 J **05.** 2108 N
06. 2.49 W **07.** a.) 30.0 hp b.) 112 hp **08.** 1.29 hp **09.** 32.5° **10.** 1.50 hp
11. a.) 2.39 hp b.) 2844 N **12.** 3.00 hours

Work, Energy, Power, & Simple Machines

Simple Machines

Homework #40

Inclined Planes

01. An inclined plane has a length 12.0 m and a height of 5.50 m.
 a.) What is the Ideal Mechanical Advantage (IMA) of this machine?
 b.) What is the minimum force needed to push a 720-kg box to the top?
02. An inclined plane has a length 17.5 m and a height of 4.25 m. A force of 255 N is required to push a 96.3-kg object to the top at a constant speed.
 a.) What is the IMA? b.) What is the AMA? c.) What is the percent efficiency?
03. What is the efficiency of a 20.0° -incline if a force of 65.0 N is required to push a 15.0-kg crate to the top?

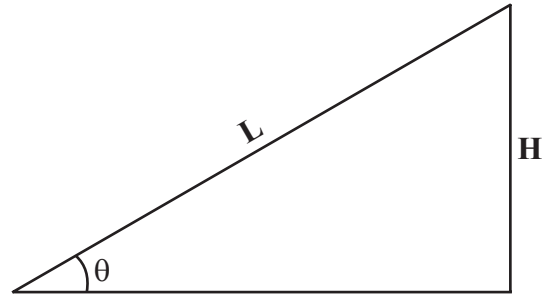

Wheel and Axle

04. A wheel and axle assembly is used at the top of a well to lift a bucket of water. The radius of the axle is 11.5 cm and the handle rotates in a circle with a radius of 48.0 cm. A force of 11.5 N must be applied to the handle to lift a 3.50-kg bucket of water.
 a.) What is the IMA b.) What is the AMA? c.) What is the percent efficiency?
05. A wheel and axle has an efficiency of 84.5%. One end of a string is tied to a 350-g mass, and the other end is wrapped around the axle. This object is lifted off the table-top at a **CONSTANT** speed when a minimum mass of 85.0 g, tied to a string wrapped around the wheel, is allowed to fall toward the table-top. If the diameter of the wheel is 12.5 cm, what is the diameter of the axle?

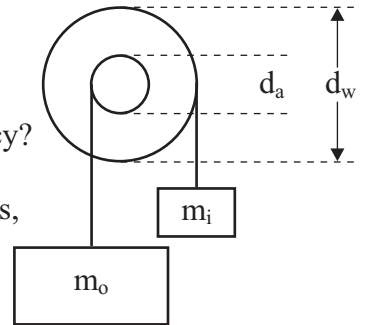

Pulleys

06. Consider the pulley system shown to the right. Assume $m_i = 91.0$ g and $m_o = 300.0$ g.
 a.) What is the IMA? b.) What is the AMA? c.) What is the percent efficiency?
07. A pulley system with 6 pulleys is used to lift a 925 lb engine out of a car. The engine must be lifted 3.00 feet to get it out of the car. The system has a percent efficiency of 79.5%.
 a.) How far must a person pull the cable to lift the engine far enough to get it out of the car?
 b.) What force is needed to lift the engine out of the car?

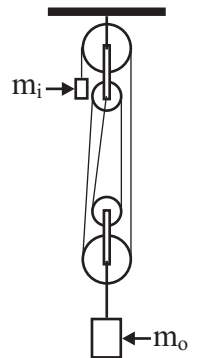

Levers

08. A lever, as shown to the right has an Effort Arm (EA) of 1.800 m and a Resistance Arm (RA) of 0.450 m. Assume m_i has a weight of 3.00 lb and m_o has a weight of 10.5 lb.
 a.) What is the IMA? b.) What is the AMA? c.) Find the % efficiency.

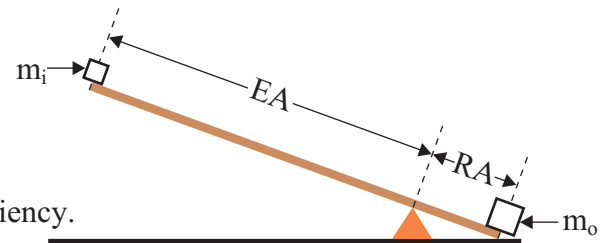

ANSWERS: **01.** a.) 2.18x b.) 3234 N **02.** a.) 4.12x b.) 3.70x c.) 89.8% **03.** 77.3%
04. a.) 4.17x b.) 2.98x c.) 71.5% **05.** 2.57 cm **06.** a.) 4x b.) 3.30x c.) 82.4%
07. a.) 18.0 ft b.) 194 lb **08.** a.) 4.00x b.) 3.50x c.) 87.5%

Work, Energy, Power, & Simple Machines

Conceptual Review

Homework #41

01. Can a centripetal force ever do work? Explain!!!
02. Can the normal force on an object ever do work? Explain!!!
03. A person is swimming upstream such that they are not moving with respect to the shore.
 - a.) Is he doing any work?
 - b.) If he stops swimming and floats, is work done on him?
04. Is the work done by kinetic friction forces always negative? Explain!!! Consider a magician pulling the tablecloth from underneath a set of china and glassware.
05. A person pushes as hard as he can against a wall for a considerable amount of time. The person has done no work, but is tired at the end. Explain!!!
06. Consider two springs with the same length. Spring 1 is stiffer (has a larger spring constant) than spring 2. On which spring is more work done if they are stretched _____? Explain!!!
 - a.) the same distance
 - b.) using the same force
07. Can kinetic energy ever be negative? Explain!!!
08. Can gravitational potential energy ever be negative? Explain!!!
09. Can elastic potential energy ever be negative? Explain!!!
10. Is the net work done on an object reference-frame dependant (depend on the reference frame)?
11. Is the change in kinetic energy reference-frame dependant? Explain!!!
12. How do the answers to 10 and 11 affect the work-energy theorem? Explain!!!
13. Is the change in gravitational potential energy reference-frame dependant? Explain!!!
14. Is the change in elastic potential energy reference-frame dependant? Explain!!!
15. Does the angle at which a projectile is launched from the top of a cliff affect the speed at which it hits the ground below? Explain!!!
16. If you compress a spring sitting upright on a table with your hand, and then release it, can it leave the table? Explain!!!
17. In the 1972 summer Olympics, a United States pole vaulter was disqualified for using an illegal pole. It was a pole made of fiberglass. Is it true that fiber glass poles can lead to higher pole vaults because the additional potential energy of bending was converted to gravitational potential energy? Explain!!!
18. What happens to the gravitational energy of the water at the top of Niagra hits the river below? Explain!!!
19. Describe all of the energy transformations that take place when a child hops on a pogo stick.
20. Describe all of the energy transformations that take place in the path of a pendulum when friction is _____.
 - a.) ignored
 - b.) taken into account and explain why a grandfather clock has to be wound
21. If an object is released from the top of an incline, does the speed it reaches at the bottom depend on the angle of the incline when _____? Explain!!!
 - a.) the incline is frictionless
 - b.) the friction of the incline is considered
22. Why do experienced hikers step over a fallen log in their path rather than stepping on the log and down on the other side? Explain!!!
23. A car accelerates uniformly from rest.
 - a.) From where does the kinetic energy of the car come?
 - b.) What is the relation between the increase in kinetic energy and the friction force the road exerts on the tires?
24. Can a "superball" that is dropped rebound to height greater than its original height?? Explain!!!
25. Which of the following factors affect the work you do in lifting a box from the floor to the table? Explain!!!
 - a.) the angle at which you lift it (straight up vs. some other path)
 - b.) time it takes
 - c.) the height of the table
 - d.) the weight of the suitcase
26. Why are mountain roads cut in a zigzag fashion rather than straight up?
27. Can a simple machine have a mechanical advantage less than one? If so what would be the purpose of such a machine?

Linear Momentum

Momentum, Force, & Momentum Conservation

Homework #42

I

01. What is the momentum of a 1225-kg car traveling 45.0 km/h?
02. A 115-kg fullback has a momentum of 517.5 kg•m/s. How fast is he moving?
03. Water leaves a hose at a rate of 1.25 kg/s with a speed of 25.0 m/s and strikes a window which stops it. What is the force exerted by water on the window?

II

04. A 68.4-kg fisherman throws a 3.15-kg fish horizontally at 12.0 m/s from a small boat with a mass of 93.6 kg. If the boat is initially at rest, calculate the velocity of the boat after the fish is thrown?
05. A 10.0-g bullet traveling horizontally at 365 m/s strikes and becomes embedded in a 2.25-kg block of wood placed on a large table. What will be the speed of the bullet-block combination immediately after impact?
06. A 131.8-kg tackler moving at 3.25 m/s tackles a 105.6-kg tailback moving at 6.35 m/s.
 - a.) What will be their mutual velocity immediately after the collision?
 - b.) What is the change in momentum of the tackler?
 - c.) What is the change in momentum of the tailback?
 - d.) What is the change in the momentum of the system consisting of the tackler and the tailback?
 - e.) If the exchange of momentum lasts 0.285 s, what force did the tackler impart on the tailback?
 - f.) If the exchange of momentum lasts 0.285 s, what force did the tailback impart on the tackler?
07. A 12,000-kg railroad car traveling at 12.0 m/s couples with an identical car. What is the speed of the joined cars?

08. An atomic nucleus undergoes an alpha decay which produces an alpha particle (Helium nucleus) and a daughter nucleus. If the recoiling daughter nucleus has a mass 59 times that of the alpha particle and the decay sends the alpha particle moving at 7.50×10^5 m/s, what will be the speed of the daughter nucleus?

III

09. A 22.0-g bullet is fired from a rifle leveled horizontally. The bullet penetrates and becomes embedded in a 1.87-kg block of wood sitting on a flat horizontal surface with a coefficient of friction of 0.32. What is the muzzle speed of the bullet, if the collision causes the block of wood to slide 6.75 m?
10. A 2.15-kg block of wood is placed on stand that has an opening in the bottom to conduct an experiment. A 15.0-g bullet is fired vertically at 620 m/s through the opening in the stand and buries itself in the wood. How high above the stand will the block of wood fly into air?
11. A small pickup truck is parked on a 14.5-m high hill. It is accidentally left in neutral without the parking brake applied and begins rolling down the hill. When it reaches the bottom it continues rolling along a horizontal road. A 122.5-kg man jumps in the back to gain control. If the speed of the truck is reduced to 15.2 m/s upon the man's entry, what is the mass of the pickup truck?
12. What is the momentum of the earth relative to the sun?

ANSWERS: **01.** 15,300 kg•m/s **02.** 4.50 m/s **03.** 31.3 N **04.** -0.233 m/s **05.** 1.62 m/s
06. a.) 1.02 m/s b.) 563 kg•m/s c.) -563 kg•m/s d.) 0 e.) -1975 N f.) 1975 N **07.** 6.00 m/s
08. 1.27×10^4 m/s **09.** 560 m/s **10.** 0.941 m **11.** 1120 kg **12.** 1.78×10^{29} kg•m/s

Linear Momentum

Impulse

Homework #43

I

01. A 0.391-kg football is thrown by a quarterback at 21.5 m/s, and caught by a receiver. What is the impulse given to the ball?
02. A 45.93-g golf ball is hit off a tee at 60.3 m/s (135 mph). The club head was in contact with the ball for a period of 8.50×10^{-3} s.
- What is the impulse imparted to the ball by the club?
 - What is the impulse imparted to the club by the ball?
 - What is the average force given to the ball by the club?
 - What is the average force given to the club by the ball?
03. A 107-kg fullback running at 7.25 m/s is stopped by a tackler in 0.945 s.
- What is the original momentum of the fullback?
 - What is the change in momentum that the fullback undergoes?
 - What is the impulse delivered to the fullback?
 - What is the average force exerted on the fullback?

II

04. A 140-g baseball pitched at 32.7 m/s is hit in a line drive at 48.5 m/s right back over the pitcher's mound. If the bat was in contact with the ball for 4.35×10^{-4} s, what was the average force given to the ball by the bat?
05. The graph to the right shows the force given to a 0.05669-kg tennis ball as a function of time by a racket.
- Estimate the impulse given to the ball?
 - If the ball were struck by the racket at the top of its path (at rest), with what speed will the ball leave the racket?
06. A kickball of mass m and a speed of v strikes a solid wall at a 45.0° angle and rebounds at the same speed and angle. What is the impulse given to the wall?

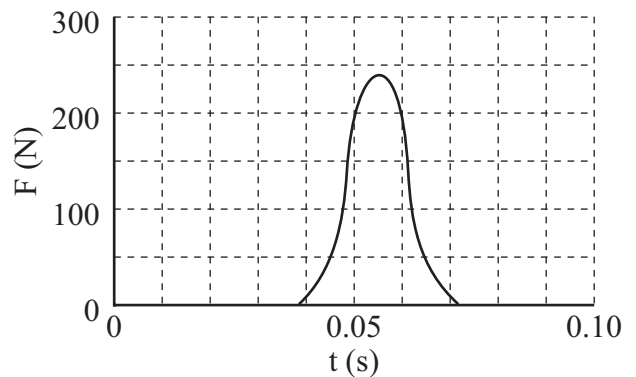

ANSWERS: **01.** $8.41 \text{ kg}\cdot\text{m/s}$ **02.** a.) $2.77 \text{ kg}\cdot\text{m/s}$ b.) $-2.77 \text{ kg}\cdot\text{m/s}$ c.) 326 N d.) -326 N
03. a.) $776 \text{ kg}\cdot\text{m/s}$ b.) $-776 \text{ kg}\cdot\text{m/s}$ c.) $-776 \text{ kg}\cdot\text{m/s}$ d.) -821 N **04.** $27,100 \text{ N}$
05. a.) $3.50 \text{ kg}\cdot\text{m/s}$ b.) 61.7 m/s (138 mi/h) **06.** $2mv\sin(45)$ [$2mv\cos(45)$]

Linear Momentum

Elastic Collisions in One Dimension

Homework # 44

II

01. A cue ball traveling 6.75 m/s collides in a perfectly elastic head-on collision with an 8-ball, which is identical to the cue ball other than the markings, sitting on the pool table. What is the velocity of each ball after the collision?

02. A girl's 5.45-kg (12 lb) bowling ball is stopped in the gutter. A boy then throws his 7.27-kg (16 lb) bowling bowl and it enters the gutter at a point on the lane well before the location of the girl's ball. The boy's ball strikes the girl's ball head-on with a speed of 32.2 km/h (20 mi/h). Assume the collision is perfectly elastic. See the diagram to the right.

- What is the velocity of each ball after the collision?
- What is the change in momentum of the girl's ball?
- What is the change in momentum of the boy's ball?
- What is the change in momentum of the system?
- What is the impulse delivered to the girl's ball?
- What is the impulse delivered to the boy's ball?
- What is the change in kinetic energy of the girl's ball?
- What is the change in kinetic energy of the boy's ball?
- What is the change in kinetic energy of the system?

03. A 4.50-kg exercise ball traveling at 3.75 m/s strikes a 2.25-kg exercise ball sitting on the gym floor in a perfectly elastic head-on collision. What are the velocities of the two balls after the collision?

04. A pool ball is moving at 4.00 m/s to the right. A second identical pool ball moving 5.00 m/s to the left collides in a perfectly elastic head-on collision with the first. What are the velocities of the two balls after the collision?

Problem 02

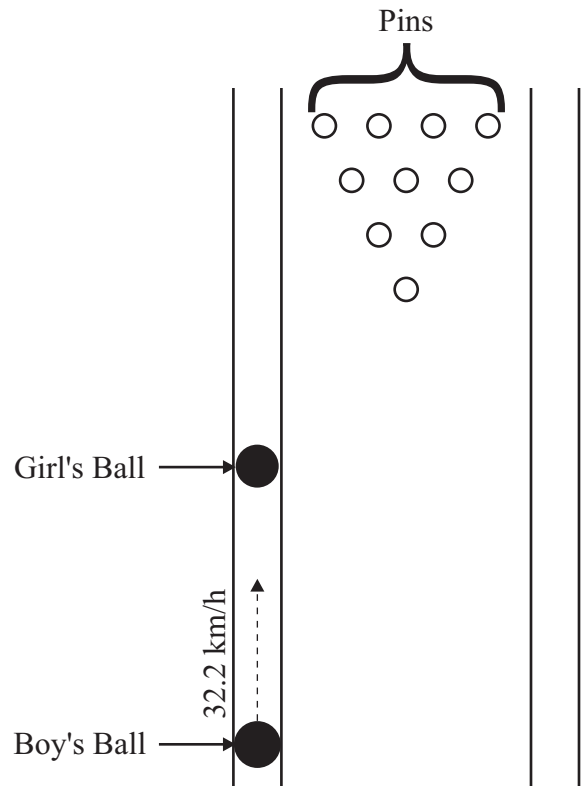

III

05. A 0.600-kg ball makes a perfectly elastic head-on collision with a second ball initially at rest. After the collision, the second ball travels off at half the original speed of the first ball.

- What is the mass of the second ball?
- What fraction of the original kinetic energy gets transferred to the second ball?

ANSWERS: **01.** 6.75 m/s **02.** a.) 1.29 m/s, 10.2 m/s b.) 55.6 kg•m/s c.) -55.6 kg•m/s d.) 0 kg•m/s
02. a.) 55.6 kg•m/s f.) -55.6 kg•m/s g.) 284 J h.) -284 J I.) 0 J **03.** 1.25 m/s, 5.00 m/s
04. -4.00 m/s, 5.00 m/s **05.** a.) 1.80 kg b.) 0.75

Linear Momentum

Elastic Collisions/Explosions in Two Dimensions

Homework #45

II

01. A Lead-211 atom undergoes a β decay to form Bismuth-211. In the process an electron and a neutrino are emitted at right angles with momenta of $6.50 \times 10^{-23} \text{ kg}\cdot\text{m/s}$ and $4.25 \times 10^{-23} \text{ kg}\cdot\text{m/s}$, respectively. What is the momentum (magnitude and direction) of the recoiling Bismuth-211 atom?
02. A boccie ball moving at 3.60 m/s strikes a second identical ball initially at rest in a perfectly elastic collision. The first ball moves off at a 36.0° angle from its original path and is moving at 2.91 m/s. Find the velocity of the second ball (magnitude and direction).
03. A blue marble traveling 1.75 m/s strikes a red marble initially at rest in a perfectly elastic collision causing the blue marble to move off at a 22.3° angle from its original path and the red marble to ricochet of at a 67.7° angle from the original path of the blue marble. Find the speed of each marble after the collision.
04. A quate (a disc used for table shuffleboard) is traveling at 2.25 m/s when it strikes a second quate at rest at the other end of the table in a perfectly elastic collision. After the collision, the first quate moves off at 1.15 m/s and the second quate moves off at an angle of 30.7° . What is the direction of the first quate and the speed of the second quate after the collision?

III

05. Two identical pool balls are approaching one another at right angles and collide in a perfectly elastic collision. The first ball was moving to the right (as seen by an observer) at 4.00 m/s and the second was moving directly away from the observer at 7.50 m/s before the collision. After the collision the first ball is moving directly away from the observer. What are the velocities (magnitude and direction) of the two balls after the collision?
06. A pool ball (Ball A) traveling 5.00 m/s strikes a second pool ball (Ball A) sitting on the table in a perfectly elastic collision. If Ball A moves off at a 23.0° angle from its original path, find the velocity of each ball (magnitude and direction).
07. An α particle (helium nucleus) moving at $5.65 \times 10^5 \text{ m/s}$ strikes a carbon atom with 3 times the mass of the α particle in a perfectly elastic collision. The α particle deflects at angle of 25.0° to its original path. Find the velocity of each ball (magnitude and direction).
08. A golf ball is traveling at 4.25 m/s when it strikes a second golf ball at rest on the green in a perfectly elastic collision. After the collision, the first ball moves off at 1.70 m/s and the second ball moves off at 3.90 m/s. What is the direction of each ball after the collision?

ANSWERS: **01.** $7.77 \times 10^{-23} \text{ kg}\cdot\text{m/s}$ @ 33.2° (56.8°) **02.** 2.12 m/s @ 54.0° **03.** 1.62 m/s, 0.664 m/s
04. 59.3° , 1.93 m/s **05.** 7.50 m/s to the right, 4.00 m/s away, 4.00 m/s to the right
06. 4.60 m/s @ 23.0° , 1.96 m/s @ 67.0° **07.** $5.48 \times 10^5 \text{ m/s}$ @ 25.0° , $8.05 \times 10^4 \text{ m/s}$ @ 73.5° **08.** 66.4° , 23.6°

Linear Momentum

Kinetic Energy Changes in Inelastic Collisions/Explosions

Homework #46

II

01. Two hockey players are skating at right angles toward one another. Just before they collide, they both fall to their butts and slide at a constant speed. Player 1 has a mass of 85.0 kg is moving at 6.25 m/s, while player 2 has a mass of 77.5 kg and is moving at 7.60 m/s. Upon colliding they cling to one another. What is their velocity (magnitude and direction) after the collision?
02. A 7000-kg railroad car (Car 1) is moving along a track at 12.5 m/s when it couples with a 10,500 kg car (Car 2) sitting on the track.
- What is the velocity (magnitude and direction) of each car after the collision?
 - What was the change in kinetic energy of system?
 - What was the change in kinetic energy of Car 1?
 - What was the change in kinetic energy of Car 2?
 - What fraction of the original kinetic energy of the system was transferred to the second car?
 - What fraction of the original kinetic energy was lost during the collision?
 - What fraction of the kinetic energy of Car 1 was lost during the collision?
03. A 20.0-g bullet traveling 275 m/s strikes and becomes embedded in a 4.25-kg pendulum hanging on a 2.95-m long string as shown in the diagram to the right.
- How high will the pendulum swing?
 - How far does the pendulum swing horizontally?
04. A radioactive decay of radium-226 can be described by ${}^{226}_{88}\text{Ra} \rightarrow {}^{222}_{86}\text{Rn} + {}^4_2\text{He}$. The helium nucleus (${}^4_2\text{He}$), which has a mass of 4.00 u , is emitted with a kinetic energy of 3.93 MeV (6.29×10^{-13} J). Assuming the ${}^{226}_{88}\text{Ra}$ nucleus (mass = 226 u) to be at rest. [Hint: This is an explosion with ${}^{226}_{88}\text{Ra}$ as one particle and ${}^4_2\text{He}$ as the other. There is no need to convert units (u and MeV) to metric units (kg and J).]
- Determine the kinetic energy of the recoiling ${}^{222}_{86}\text{Rn}$ nucleus (mass = 222 u).
 - Determine the total energy released in the decay.

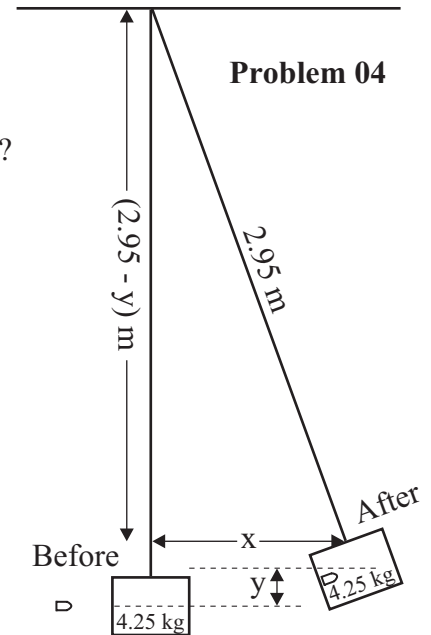

- [Note: A megaelectronvolt is a unit of energy on an atomic level. 1 MeV = 1 million electron volts = 1.6×10^{-13} J.]
- [Note: An atomic mass unit, u , is a unit of mass on the atomic level. $1 u = 1.67 \times 10^{-27}$ kg]
- [Note: The two notes above are just points of interest-they are not needed to calculate the solutions]

III

05. An explosion breaks an object into two pieces. One piece has a mass 2.5 times the other. If 8500 J of energy are released during the explosion, how much kinetic energy did each piece acquire?

ANSWERS: 01. 4.88 m/s @ 48.0° , (42.0°)

02. a.) 5.00 m/s b.) -3.28×10^5 J c.) -4.59×10^5 J d.) 1.31×10^5 J e.) 0.24 f.) 0.6 g.) 0.84

03. a.) 0.0846 m b.) 0.702 m 04. a.) 0.07 MeV (1.12×10^{-14} J) b.) 4.00 MeV (6.40×10^{-13} J)

05. $KE_1 = 6071$ J, $KE_2 = 2429$ J

Linear Momentum

Center of Mass

Homework #47

Center of Mass of Parts of Typical Male Human Body
(Taken From *Bioastronautics Data Book*, NASA, Washington, DC)

Distance of Hinge Points (%)	Hinge Points (•) (Joints)	Center of Mass (x) (% of Height Above Floor)	Percent Mass	
91.2	Base of skull on spine	Head	93.5	6.9
81.2	Shoulder joint	Trunk and Neck	71.1	46.1
		Upper Arms	71.7	6.6
	Elbow 62.2	Lower Arms	55.3	4.2
	Wrist 46.2	Hands	43.1	1.7
52.1	Hip	Upper Legs (Thighs)	42.5	21.5
28.5	Knee	Lower Legs	18.2	9.6
4.0	Ankle	Feet	1.8	3.4
				100.0

II

01. The distance between a carbon atom ($m = 12.0 u$) and an oxygen atom ($m = 16.0 u$) in a carbon monoxide molecule (CO) is 113 pm ($1\text{pm} = 10^{-12} \text{ m}$). Calculate the center of mass of the molecule.
02. A 6'2" person fits the mold of the typical male human being described above. Using the floor as an x-axis and a vertical plane passing through his shoulder as y-axis. Determine the center of mass of his arm if it is _____.
- outstretched (answer in terms of a percentage of his height)
 - outstretched (answer in inches)
 - bent at a 90.0° angle upward (answer in terms of a percentage of his height)
 - bent at a 90.0° angle upward (answer in inches)
03. A 1400-kg car has a center of mass that is 3.25 m from the front of the car. Determine the center of mass of the car when two 85.0-kg adults sit in the front seat (2.90 m from the front of the car) and three children (with an average mass of 55.0 kg) sit in the back seat (4.30 m from the front of the car).

III

04. A 30.0-lb piece of plywood (8 foot by 4 foot) is placed on two saw horses. A 7.25-lb power saw is placed on one corner while a 10.1 lb-kg can of nails is placed on the corner that is 4 feet from the saw. Determine the center of mass of system (from the end with the power saw and nails).

ANSWERS: **01.** 64.6 pm from C atom (48.4 pm from O atom) **02.** a.) $X_{\text{cm}} = 18.9\%$, $Y_{\text{cm}} = 81.2\%$
02. b.) $X_{\text{cm}} = 14.0 \text{ in}$, $Y_{\text{cm}} = 60.1 \text{ in}$ c.) $X_{\text{cm}} = 14.0\%$, $Y_{\text{cm}} = 86.1\%$ d.) $X_{\text{cm}} = 10.3 \text{ in}$, $Y_{\text{cm}} = 63.7 \text{ in}$
03. 3.32 m **04.** $X_{\text{cm}} = 2.12 \text{ ft}$, $Y_{\text{cm}} = 2.53 \text{ ft}$ from power saw ($X_{\text{cm}} = 1.88 \text{ ft}$, $Y_{\text{cm}} = 2.53 \text{ ft}$ from can of nails)

Linear Momentum

Center of Mass and Translational Motion

Homework #48

II

01. A rocket is fired into the air as shown in the diagram below. Once the rocket is airborne, the engines for liftoff have exhausted their fuel so the rocket is following a projectile motion path. At the exact moment it reaches the highest point of its path (a horizontal distance D from its starting point) rockets between the two stages fire causing the two stages to separate. The separation blast has just the exact amount of force between the two stages to completely stop the momentum of stage I causing it to fall straight down to the ground below at the horizontal distance D from its starting point. Determine how far from the starting point stage II will land if

a.) $m_I = m_{II}$

b.) $m_I = 2m_{II}$

c.) $2m_I = m_{II}$

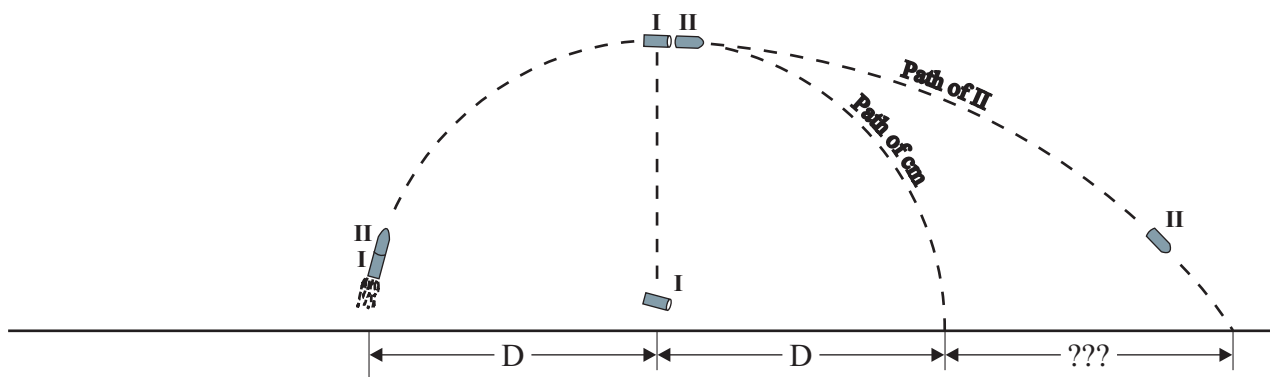

02. A 60.0-kg girl and an 85.0-kg boy are standing 12.0 m apart on frictionless ice each holding onto one end of a rope with negligible mass that is between them.
- How far from the girl is the center of mass of the system (boy and girl)?
 - If the girl pulls on her end of the rope (while the boy is holding tightly onto his end), how far away from the girl will the boy be when the girl moves 3.0 m.?
 - How far will the boy move before colliding with the girl?
03. Use the planetary data from Homework #26 (from the chapter on "Circular Motion and Gravitation") to determine how far from the earth's center is the location of the center of mass between the earth and the moon. Does the moon really orbit the earth in an elliptical path? Does the earth really orbit the sun in an elliptical path?

ANSWERS: **01.** a.) $3D$ b.) $4D$ c.) $\frac{5}{2}D$ **02.** a.) 7.03 m b.) 6.88 m c.) 4.97 m **03.** 4.66×10^6 m

Linear Momentum

Conceptual Review

Homework #49

01. Most objects that are moving eventually slow down and stop. Is this a violation of the law of conservation of momentum? Explain!!!
02. When a person jumps off a chair, what happens to the momentum of the person after landing on the floor?
03. Use the law of conservation of momentum to explain how a fish propels itself forward in the water as it swishes its tail back and forth.
04. A balloon is inflated and then released. Why does it fly across the room?
05. It is said that in ancient times a rich man with a bag of gold coins froze to death stranded on the surface of a frozen lake. Because the ice was frictionless, he could not push himself to shore. Had he not been so miserly, what could he have done to save himself?
06. How can a rocket that is coasting through outer space, which is essentially a vacuum, change direction? Explain!!!
07. The concept of impulse implies that the shorter the time interval for a given change in momentum of an object, the greater force acting on that object. Using this concept, explain how air bags reduce the possibility of injury or death during an automobile accident?
08. An object (Object 1) is to receive an impulse from a second object (Object 2) in one of two possible ways. Object 2 can deliver the impulse with a relatively large force in Scenario A, or it can deliver the impulse with a relatively small force in Scenario B. Can Object 1 receive a larger impulse from Scenario B than Scenario A? Explain!!!
09. A light body and a heavy body have the same kinetic energy. Which has greater momentum? Explain!!!
10. A light body and a heavy body have the same momentum. Which has greater kinetic energy? Explain!!!
11. Is it possible for an object to have momentum without having energy? Can it have energy without having momentum? Explain!!!
12. Which of the following types of accidents is more likely to result in injuries to the occupants in a head-on collision: Scenario A in which two cars collide such that the front of each car crumples considerably and the two cars remain together, or Scenario B in which the two cars rebound backward after colliding? Explain!!!
13. A superball is dropped from a certain height, falls, and hits a hard steel plate securely attached to the earth. The superball bounces back to nearly its same height, though not quite. Is momentum conserved? Is momentum conserved if instead a piece of putty is dropped and it sticks to the steel plate instead of rebounding? Explain!!!
14. Why does one tend to lean backward when carrying a heavy load in his arms?
15. The cm of a piece of iron pipe is right at its midpoint. This is not true for your arm or leg. Why? Explain!!!
16. Using a diagram, show how one's center of mass changes when he shifts from a lying position to a sitting position.
17. A uniform rectangular brick can be placed on the edge of the table such that slightly less than half of its length can be suspended over the edge, but no more or it will fall. Why? Explain!!!

Rotational Motion

Angular Quantities

Homework #50

I

01. Convert the following angle measurements to radians.
a.) 30.0° b.) 45.0° c.) 90.0°
02. The Empire State Building has a total height of 443.2 m (including the lightning rod). From one observation point on a street in New York, it subtends an angle of 5.50° . How far from the building is this observation point?
03. A laser beam, shining from the earth's surface, is directed at the moon whose distance from the earth on this day is 370,000 km. If the beam diverges at an angle of only 1.65×10^{-5} rad, what diameter circle will it make on the moon?
04. A Compact Disc (CD) has a diameter of 12.0 cm, rotates at a constant 207 rpm, and has a total playing time of 74.0 minutes.
 - a.) What is the angular velocity of the CD?
 - b.) What is the linear speed of a point on the edge of the disc?
 - c.) What is the angular displacement of the CD during its total play time?
 - d.) What is the distance traveled by a point on the edge of the CD?
 - e.) What is the distance traveled by a point 4.00 cm from the center of the CD?
 - f.) What is the angular acceleration of the CD during its total play time?
 - g.) What is the tangential acceleration of a point on the edge of the CD?
 - h.) What is the centripetal acceleration of a point on the edge of the CD?
05. An antique grinding wheel rotating at 85.0 rpm is brought to rest in 22.5 s. What is its angular acceleration?

II

06. A centrifuge is rotated from rest to 18,000 rpm in 4 minutes and 45 seconds. What is the average angular acceleration of the centrifuge during this time?
07. A bicycle with tires of diameter 68.0 cm travels 13.5 km. How many revolutions do the wheels make?
08. Calculate the angular velocity of the earth _____.
 - a.) in its orbit around the sun
 - b.) about its axis
09. What is the linear speed of a point _____ due to the earth's rotation about its axis. (See [Homework #26](#) of "Circular Motion & Gravitation" for Planetary Data)
 - a.) on the equator
 - b.) at a latitude of 60.0° N
10. A phonograph record with a diameter of 30.0 cm reaches its rated speed of 33 rpm in 3.5 s.
 - a.) What is the tangential component of the linear acceleration of a point on the edge of the record?
 - b.) What is the centripetal component of the linear acceleration of a point on the edge of the record 2.50 s after it starts rotating?

ANSWERS: **01.** a.) 0.524 rad b.) 0.785 rad c.) 1.57 rad **02.** 4617 m **03.** 6105 m **04.** a.) 21.7 rad/s
04. b.) 1.30 m/s c.) 9.62×10^4 rad d.) 5775 m e.) 3850 m f.) 0 rad/s² g.) 0 m/s² h.) 28.2 m/s²
05. -0.396 rad/s² **06.** 6.61 rad/s² **07.** 6320 rev **08.** a.) 1.99×10^{-7} rad/s b.) 7.27×10^{-5} rad/s
09. a.) 464 m/s b.) 232 m/s **10.** a.) 0.148 m/s² b.) 0.914 m/s²

Rotational Motion

Uniformly Accelerated Rotational Motion

Homework #51

I

01. A phonograph turntable reaches its rated speed of 33 rpm in 2.25 revolutions. What is its angular acceleration?
02. A centrifuge accelerates from rest to 12,000 rpm in 235 s. What was the centrifuge's angular acceleration?

II

03. A truck engine slows down from 3700 rpm to 1800 rpm in 4.25 s. How many revolutions were made by the engine during this time?
04. A car, with 26-inch (66.0-cm)-diameter wheels, accelerates from rest to 72.5 km/h (45.0 mi/h) in 295 m.
- What is the angular displacement of the wheels?
 - What is the **AVERAGE** angular velocity of the wheels?
 - What is the angular acceleration of the wheels?
 - How long did it take to reach this speed?
05. A train that has wheels with a diameter of 91.44 cm (36 inches used for 100 ton capacity cars) slows down from 82.5 km/h to 32.5 km/h as the train approaches a town. The wheels of the train make 95.0 revolutions in this time.
- What is the angular acceleration of the wheels?
 - How long does it take the train to make this reduction in speed?
 - How far does the train travel during this deceleration period?
 - Assuming the same rate of deceleration, how many **MORE** revolutions will the wheels make before stopping?
 - Assuming the same rate of deceleration, how much **FARTHER** will the train travel before stopping?
06. A bicycle wheel (Wheel 1) with a diameter of 68.0 cm is mounted such that its circular edge touches that of a second bicycle wheel (Wheel 2) with a diameter of 42.0 cm. Wheel 1 accelerates at a rate of 1.28 rad/s^2 and drives the second wheel through its contact with negligible slipping.
- How long will it take Wheel 1, starting from rest, to reach a rotation rate of 25.0 rpm?
 - What is the linear speed of a point on the edge of Wheel 1 when it rotates at 25.0 rpm?
 - How far does a point on the edge of Wheel 1 travel in the time needed to reach a rotation rate of 25.0 rpm?
 - What is the angular acceleration of Wheel 2?
 - How long will it take Wheel 2, starting from rest, to reach a rotation rate of 25.0 rpm?
 - What is the linear speed of a point on the edge of Wheel 2 when it rotates at 25.0 rpm?
 - How far does a point on the edge of Wheel 2 travel in the time needed to reach a rotation rate of 25.0 rpm?

III

07. A 68.0-cm bicycle wheel accelerates from 165 rpm to 280 rpm in 8.45 s. How far will the bicycle have traveled in this time?

ANSWERS: **01.** 0.422 rad/s^2 **02.** 5.35 rad/s^2 **03.** 195 rev **04.** a.) 894 rad b.) 30.5 rad/s
04. c.) 2.08 rad/s^2 d.) 29.3 s **05.** a.) -1.78 rad/s^2 b.) 17.1 s c.) 273 m d.) 17.5 rev e.) 50.1 m
06. a.) 2.05 s b.) 0.890 m/s c.) 0.910 m d.) 2.07 rad/s^2 e.) 1.26 s f.) 0.550 m/s g.) 0.348 m
07. 66.9 m

Rotational Motion

Torque

Homework #52

I

01. An 76.5-kg person is riding a bike whose pedals rotate in a circle with a diameter of 34.6 cm. What is the maximum torque exerted by the rider on the pedals assuming he puts all of his weight on the pedals?
02. A woman opens an 75.8-cm wide door for a man by applying a force of 34.3 N to the edge of the door.
- Calculate the maximum torque applied to the door.
 - Calculate the torque applied to the door if the force is applied at a 60.0° angle to the face of the door.

II

03. What is the net torque applied to the wheel and axle assembly shown in the diagram to the right? Assume a frictional torque of $0.40 \text{ N}\cdot\text{m}$. The axle has a radius of 30.0 mm and the wheel has a radius of 80.0 mm. All forces are tangent.
04. The wheel lug nuts of a 1988 Jeep Wrangler require tightening to a torque of $80 \text{ ft}\cdot\text{lb}$ ($108.6 \text{ N}\cdot\text{m}$). A mechanic uses a 30.0-cm long wrench (shown in the diagram below).
- What is the minimum force needed by a mechanic to tighten this nut to factory specifications?
 - What force is applied to each point on the six-sided nut with a diameter of 20.0 mm when the bolt is tightened to factory specifications?

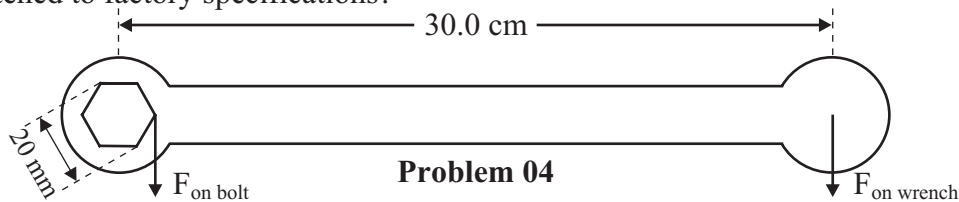
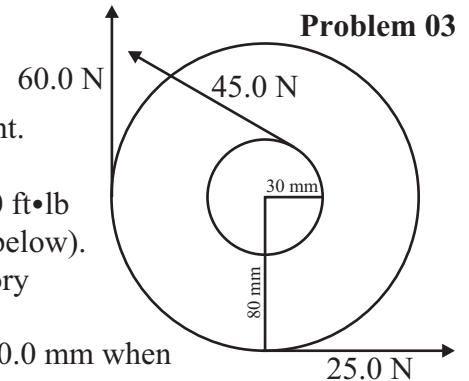

Problem 04

III

05. The torque lab apparatus is assembled as shown below. The hooks of the spring scales are inserted in holes drilled in the meter stick exactly 1.00 cm from the ends of the meter stick. Spring scale 1 has a reading of 2.62 N. The weights are hung from paper clips that are inserted in holes drilled in the meter stick as follows: $m_1 = 200 \text{ g}$ hung at 30.0 cm; $m_2 = 100 \text{ g}$ hung at 60.0 cm; $m_3 = 50 \text{ g}$ hung at 70.0 cm (all distances given are from the left edge of the meter stick). The mass of the meter stick is 135.0 g and the mass of each paperclip is 3.325 g. The apparatus is at rest and in dynamic equilibrium. Determine _____.
- the reading on spring scale 2
 - the net clockwise torque
 - the net counter-clockwise torque
 - the net experimental torque

Note: The spring scales (not shown) are supported by ring stands (not shown).

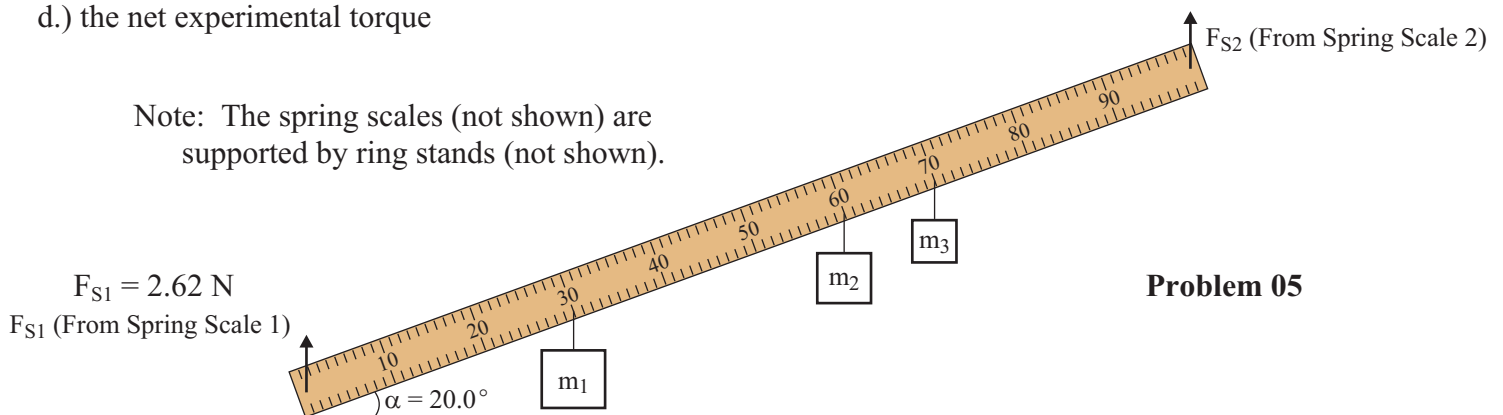

Problem 05

ANSWERS: **01.** $130 \text{ N}\cdot\text{m}$ **02.** a.) $26.0 \text{ N}\cdot\text{m}$ b.) $22.5 \text{ N}\cdot\text{m}$ **03.** $-1.05 \text{ N}\cdot\text{m}$ **04.** a.) 362 N b.) 1810 N
05. a.) 2.23 N b.) $-2.18 \text{ N}\cdot\text{m}$ c.) $2.19 \text{ N}\cdot\text{m}$ d.) $0.01 \text{ N}\cdot\text{m}$

Rotational Motion

Moment of Inertia

Homework #53

1.) Mass on a String, Planet Orbiting a Star

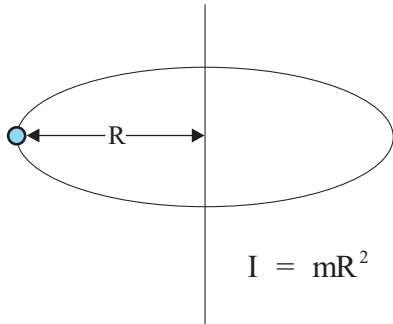

$$I = mR^2$$

2.) Ring, Hoop

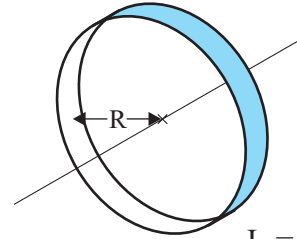

$$I = mR^2$$

3.) Disk, Cylinder

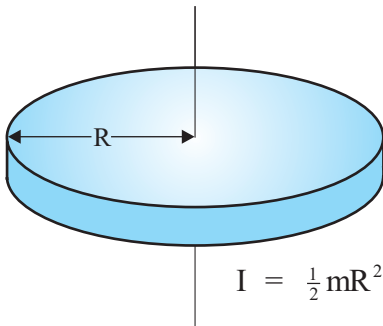

$$I = \frac{1}{2}mR^2$$

4.) Solid Sphere

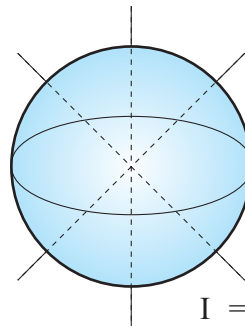

$$I = \frac{2}{5}mR^2$$

5.) Thin Rod Rotating About One End

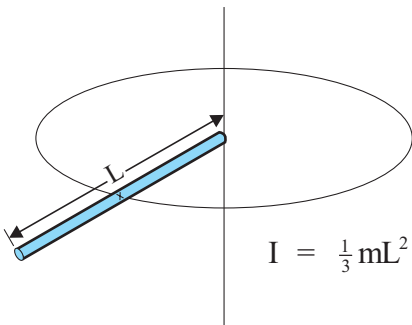

$$I = \frac{1}{3}mL^2$$

6.) Thin Rod Rotating About Center

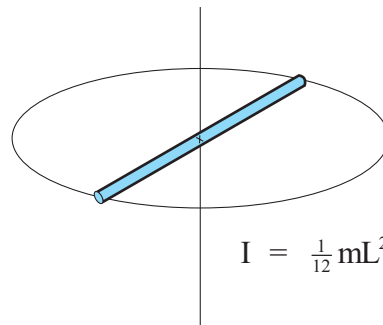

$$I = \frac{1}{12}mL^2$$

Rotational Motion

Rotational Dynamics

Homework #54

I

01. What is the moment of inertia of a 6.75-kg solid sphere with a radius of 0.682 m with a rotation axis passing through the center of the sphere?
02. A bicycle wheel has a diameter of 68.0 cm. The combined mass of its tire and rim is 1.18 kg while the inertial factor of the hub can be ignored. What is the moment of inertia of the wheel?

II

03. A 0.875-kg solid ball is tied to a string and rotated in a circle of radius 0.925 m. A force of air resistance of 0.0245 N acts as the ball rotates.
- What is the moment of inertia of the ball?
 - What torque must be applied to the ball to keep it rotating at a constant angular velocity?
04. A pottery wheel is a uniform cylinder that has a diameter of 30.48 cm and a mass of 5.00 kg. The wheel starts from rest and accelerates to 125 rpm in 10.5 s. A frictional torque of 0.0460 N•m acts as it rotates. What is the torque applied to this wheel to cause this acceleration?
05. A solid sphere with a diameter of 0.784 m is spun around an axis passing through the center of the sphere. If a torque of 17.5 N•m is applied for 22.5 s causing the sphere to rotate from rest through 215 revolutions. What is the mass of the sphere?
06. Treat a merry-go-round as a uniform disc that has a diameter of 19.0 m and a mass of 35,000 kg. Assuming a frictional torque of 1220 N•m, what torque is needed to accelerate it from rest to 2.25 rad/s in 12.5s?
07. A 15.4-lb (7.00-kg) medicine ball with a diameter of 28.0 cm is sitting on the gym floor. A force of 178 N is applied to the top edge of the ball (tangent to the surface) for 0.125 s.
- What is the moment of inertia of the ball?
 - What is the torque applied to the ball?
 - What is the angular acceleration of the ball while the force is being applied?
 - What is the angular velocity of the ball after the acceleration period of 0.125 s?
 - What is the angular displacement of the ball during the acceleration period?
 - How far across the floor will the ball roll during the acceleration period?
08. A centrifuge rotor rotating at 12,000 rpm is shut off. The centrifuge has a radius of gyration of 0.0685 m and a frictional torque of 1.48 N•m. The mass of the rotor is 4.45 kg.
- How many revolutions will the rotor make before coming to rest?
 - How long will it take to stop?

ANSWERS: **01.** 1.26 kg•m² **02.** 0.136 kg•m² **03.** a.) 0.749 kg•m² b.) 0.0227 N•m **04.** 0.118 N•m
05. 53.3 kg **06.** 2.85 x 10⁵ N•m
07. a.) 0.0549 kg•m² b.) 24.9 N•m c.) 454 rad/s² d.) 56.8 rad/s e.) 3.55 rad f.) 0.497 m
08. a.) 1773 rev b.) 17.7 s

Rotational Motion

Rotational Work & Kinetic Energy

Homework #55

I

01. A phonograph record (uniform disc) has a mass of 112 g and a diameter of 30.0 cm. It is rotating on a turntable at 33 rpm when the turntable is turned off. How much energy does the record lose in coming to rest?
02. A 68.0-cm bicycle wheel, with a mass of 4.50 kg, is mounted on a lab table. A student grabs the tire and applies a 65.0-N force tangentially for $\frac{1}{2}$ of a rotation and releases it.
- How much work was done by the student?
 - What is the kinetic energy of the wheel after the student releases it?
 - What is the angular velocity of the wheel after the student releases it?

II

03. What is the kinetic energy of the earth _____? (See [Homework #26](#) of "Work, Energy, Power, and Simple Machines" for Planetary Data)
- in rotating about its axis
 - in revolving around the sun
04. A 3.50-kg solid ball, with a radius of 0.345 m, begins rolling down a 4.50-m high incline without slipping.
- What speed will it have when it reaches the ground?
 - What is the angular velocity it is rolling at when it reaches the ground?
 - What is the **TOTAL** kinetic energy of the ball when it reaches the ground?
05. A car has a mass of 1400 kg including the four tires which each have a mass of 35.0 kg (including the wheels), a diameter of 86.36 cm, and a radius of gyration (of tire and wheel) of 32.5 cm.
- What is the translational kinetic energy of the car when it is traveling 90.0 km/h?
 - How much total (trans. + rot.) kinetic energy is in the wheels of the car when it is traveling 90.0 km/h?
 - If the car is pulled by a tow truck with a force of 2500 N, what will be the acceleration of the car?
Hint: The force of friction on the tires from the road creates a torque on the tires and rotates them.

III

06. A 68.0-cm bicycle wheel, with a mass of 4.50 kg, is mounted on a lab table. A string that is 60.0 cm long has loops tied on both ends. One loop is placed over a nail sticking out of the hub of the wheel and the length of the string is wrapped around the hub that has a diameter of 2.75 cm. A 500-g mass is hung from the other loop. The mass is released and the wheel begins to rotate as the weight falls and unwraps the string. All questions below refer to the time when the string is completely unraveled. See the diagram to the right. Ignore frictional losses.
- How much work is done by the mass?
 - What is the angular velocity of the wheel?
 - What is the kinetic energy of the wheel?
 - What is the kinetic energy of the falling mass?
 - What is the total kinetic energy of the system?

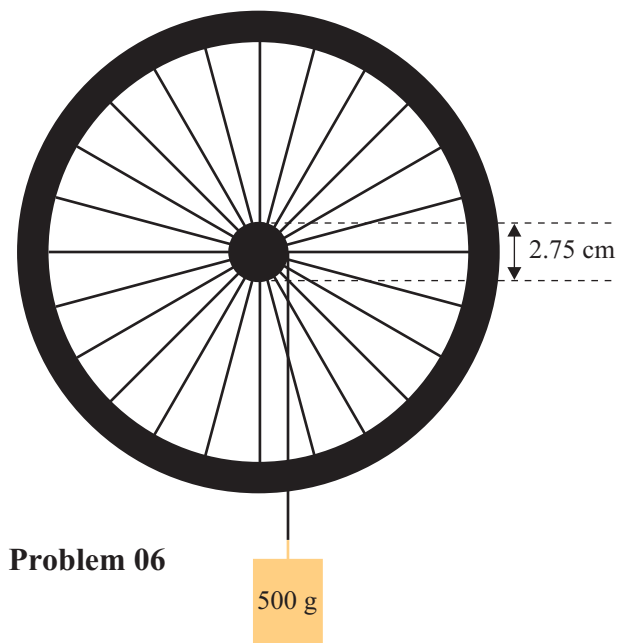

ANSWERS: **01.** 0.00754 J **02.** a.) 69.4 J b.) 69.4 J c.) 16.3 rad/s **03.** a.) 2.57×10^{29} J b.) 2.64×10^{33} J
04. a.) 7.94 m/s b.) 23.0 rad/s c.) 154 J **05.** a.) 4.38×10^5 J b.) 6.85×10^4 J c.) 1.69 m/s^2
06. a.) 2.94 J b.) 3.36 rad/s c.) 2.94 J (2.939465 J) d.) 5.34×10^{-4} J e.) 2.94 J

Rotational Motion

Conceptual Review

Homework #57

01. How can you determine the height of a telephone pole or tree using only your finger, a meter stick, and a calculator. Explain!!!
02. Could an odometer designed for bicycles with 27-inch wheels be used accurately on a bike with 24-inch wheels? Explain!!!
03. Consider a 33-rpm record rotating at its rated speed on a turntable.
 - a.) Does a point on the outer edge have centripetal and/or tangential acceleration? Explain!!!
 - b.) Does a point on the outer edge have centripetal and/or tangential acceleration during the time the record increases its angular velocity from rest to its rated speed? Explain!!!
 - c.) Discuss when the magnitudes of the centripetal and tangential acceleration change in parts a.) and b.) above.
04. Is it possible for a small force to create a larger torque on an object than a larger force acting on this object? Explain!!!
05. A force acts on object at such an orientation that its lever arm, r , is zero. Does this force have any effect on the object's motion? Explain!!!
06. Racing bicyclists use very lightweight "sew-up" (tubular) tires. The assumption is that reducing the mass of the tires is more significant than an equal reduction in mass elsewhere on the bike. Explain why this is true.
07. Mammals that must run quickly to survive have slender lower legs and most of the muscle and flesh of the leg concentrated high, close to the body. Why is this advantageous to speed for the animal? Explain!!!
08. Why do tightrope walkers carry a long, narrow beam? Explain!!!
09. Is the net torque on a system zero if the net force is zero? Explain!!!
10. Is the net force on a system zero if the net torque is zero? Explain!!!
11. A meter stick stands vertically on one end on a **FRICTIONLESS** surface. Describe the motion of its cm and of each end when it is tipped slightly to one side and falls? Explain!!!
12. A ring, a disc, and a solid ball all start from rest and begin simultaneously rolling down an incline. Give the order of their finish. Explain!!!
13. Solid ball 1 is rolled down an incline while an identical ball, solid ball 2, starting at the same height as ball 1, is rolled down another incline with a larger angle.
 - a.) Which ball will have the greatest speed at the bottom if they both start from rest? Explain!!!
 - b.) Which ball will reach the bottom first if they both start from rest? Explain!!!
14. Two solid balls simultaneously begin rolling from rest down an incline. Ball 2 has twice the mass and twice the radius of ball 1.
 - a.) Which ball has the greater speed at the bottom? Explain!!!
 - b.) Which ball reaches the bottom of the incline first? Explain!!!
 - c.) Which ball has the greater total kinetic energy at the bottom? Explain!!!
15. A solid ball and a disc with the same mass and radius simultaneously begin rolling from rest down an incline.
 - a.) Which object has the greater speed at the bottom? Explain!!!
 - b.) Which object has the greater total kinetic energy at the bottom? Explain!!!
 - c.) Which object has the greater translational kinetic energy at the bottom? Explain!!!
 - d.) Which object has the greater rotational kinetic energy at the bottom? Explain!!!
16. A cyclist rides over the top of a hill. Is the bike's motion considered rotational, translational, or a combination? Explain!!!
17. If there were a great migration of people toward the equator, how would this affect the length of the day? Explain!!!
18. In our experience, rotating objects eventually slow down and stop. Is this a violation of the law of conservation of momentum? Explain!!!
19. Describe the direction of the earth's angular velocity in its daily rotation about its axis.

Rotational Motion

Conceptual Review

Homework #58

20. Evil Knevil jumps a line of cars. While in the air, the motorcycle's throttle is left open causing the rear wheel to spin. Why does this cause the front of the motorcycle to rise up?
21. Consider the second hand of a clock that moves continuously.
 - a.) What is the direction of the angular velocity? Explain!!!
 - b.) What is the direction of the angular acceleration? Explain!!!
 - c.) What is the direction of the **NET** torque? Explain!!!
 - d.) What is the direction of the angular momentum? Explain!!!
22. A wheel is rotating such that its angular velocity has a horizontal direction pointing due west.
 - a.) What is the direction of the linear velocity of a point on the top edge of the wheel? Explain!!!
 - b.) Is the angular velocity increasing or decreasing if the angular acceleration of the wheel has a direction east? Explain!!!
23. A quarterback leaps into the air to throw a forward pass. While in the air, his upper body rotates to make the pass. Why does his hips and legs rotate in the opposite direction? Explain!!!
24. Use the law of conservation of momentum to explain why a helicopter must have a rotor, or propeller, on its tail section at right angles to its main rotor on the top of the cab. How does this affect stability? Explain!!!
25. A physics teacher is sitting on a stool that is free to rotate. The teacher is currently at rest and is holding a bicycle wheel with one hand on either side of the axle. The wheel is spinning very quickly and is oriented so that its angular momentum is in a direction straight up toward the ceiling. With his feet off the ground, the physics teacher quickly rotates the wheel's orientation $\frac{1}{2}$ turn such that the direction of the angular momentum of the wheel is now down. Describe the resulting motion of the physics teacher. Explain!!!

Simple Harmonic Motion & Waves

Simple Harmonic Motion-Elastic Oscillators

Homework #59

I

01. If an object is vibrating in SHM with an amplitude of 7.00 cm, what is the total distance traveled in one cycle?
02. A rubber band is 12.5 cm long when a 50.0-g mass is hanging from one end. This same rubber band is 16.3 cm when an 80.0-g mass is **ADDED** to the original mass. What is the effective "spring" constant of the rubber band?
03. The springs in a 1350-kg car compress 1.85 cm when a 92.5-kg person gets in the car.
 - a.) What is the spring constant of the spring system?
 - b.) What is the frequency of vibration when the car hits a bump in the road?
04. A fly with a mass of 0.650 g is caught in a spider's web that vibrates at 12.5 Hz.
 - a.) What is the effective "spring" constant for the web?
 - b.) What would be the frequency of the web if a 1.15-g insect were trapped and struggling to escape?

II

05. A fisherman's scale stretches 4.25 cm when a 3.85-kg fish is hung from it. If the fish is pulled down an additional distance and released, with what frequency will the fish vibrate?
06. A 400-g mass at the end of a spring vibrates 3.00 times per second with an amplitude of 14.00 cm.
 - a.) What is velocity when it passes the equilibrium point?
 - b.) What is its maximum velocity during a cycle?
 - c.) What is its velocity when it is 9.00 cm from the equilibrium position?
 - d.) Write an equation that describes the position of this vibrating system as a function of time assuming the displacement is a maximum when the vibration begins.
07. The position as a function of time of a 1.25-kg mass vibrating on a spring can be described as $x = 0.56 \cos(2.80t)$.
 - a.) What is the amplitude of the vibration?
 - b.) What is the frequency of the vibration?
 - c.) What is the total energy of the system?
08. A 75.0-N force is required to compress the spring of a dartgun 18.0 cm to load a 125-g dart. With what speed will the ball leave the gun?

09. A 1500-g mass is hung from a vertical spring causing it to stretch 14.0 cm. The mass is struck with a hammer vertically upward giving it an initial speed of 2.25 m/s.
 - a.) What is the spring constant?
 - b.) What is the frequency of the vibration?
 - c.) What is the period of the vibration?
 - d.) What is the amplitude of the vibration?
 - e.) What is the total energy of the system?
 - f.) What equation describes the position as a function of time?

III

10. A 15.0-g bullet is fired and becomes embedded in a 0.525-kg block sitting on a surface and attached to a horizontal spring with the other end of the spring attached firmly to the wall. The spring has a spring constant of 7200 N/m. The impact of the bullet sets the system into vibration with an amplitude of 14.5 cm. What was the muzzle speed of the bullet? See Diagram on the bottom of the next page (Homework #58).

ANSWERS: **01.** 28.0 cm **02.** 20.6 N/m **03.** a.) 49,000 N/m b.) 0.928 Hz **04.** a.) 4.01 N/m b.) 9.39 Hz
05. 2.42 Hz **06.** a.) 2.64 m/s b.) 2.64 m/s c.) 2.02 m/s d.) $x = 0.14 \cos(18.85 t)$
07. a.) 0.56 m b.) 0.446 Hz c.) 1.54 J **08.** 10.4 m/s
09. a.) 105 N b.) 1.33 Hz c.) 0.751 s d.) 26.9 cm e.) 3.80 J f.) $x = 0.269 \sin(8.37 t)$ **10.** 603 m/s

Simple Harmonic Motion & Waves

Simple Harmonic Motion-Pendulums

Homework # 60

I

01. A pendulum makes 20.0 vibrations in 34.6 s.
a.) What is the frequency of the pendulum? b.) What is the period of the pendulum?
02. What is the length of a pendulum that makes completes exactly one cycle per second?

II

03. What is the period of a pendulum 1.45 m long _____?
a.) on earth b.) on an elevator in freetail
04. A pendulum is pulled back 1.45 m and released as a stopwatch is started. The pendulum oscillates with a frequency of 1.25 Hz. Ignoring any losses of energy, what will be the position of the bob at $t =$ _____?
a.) 0.200 s b.) 0.400 s c.) 11.7 s d.) 400 s
05. A pendulum has a bob with a mass of 2.50 kg and is 1.85 m long. The bob is pulled back 1.10 m and released.
a.) What is the frequency of the pendulum?
b.) What is the bob's speed as it passes through the lowest point of the swing?
c.) What is the bob's speed when it is 35.0 cm from the lowest point of its path?
d.) Write an equation that describes the position of this bob as a function of time.
e.) Where is the bob after 14.0 s?
f.) Write an equation that describes the velocity of this bob as a function of time.
g.) What is the velocity of the bob after 14.0 s?
h.) Write an equation that describes the acceleration of this bob as a function of time.
I.) What is the acceleration of the bob after 14.0 s?
06. What is the effective value of the acceleration due to gravity at a location on the earth where a pendulum that is 2.50 m long has a frequency of 0.316 Hz?
07. A pendulum has a length of 0.750 m and is pulled back 0.150 m and released. By what factor will the period change if the following alterations to the pendulum are made?
a.) Quadrupling the amplitude.
b.) Quadrupling the mass.
c.) Quadrupling the length.

Problem 10 Homework #59 Previous Page

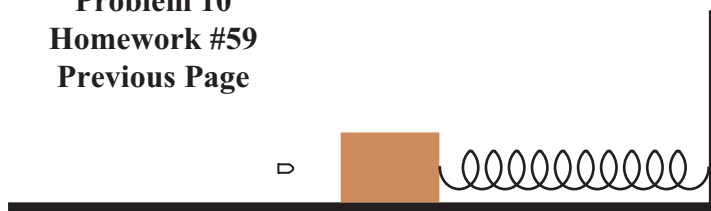

ANSWERS: **01.** a.) 0.578 Hz b.) 1.73 s **02.** 0.248 m **03.** a.) 2.42 s b.) ∞
04. a.) 0 m b.) -1.45 m c.) -1.03 m d.) 1.45 m **05.** a.) 0.366 Hz b.) 2.53 m/s c.) 2.40 m/s
05. d.) $x = 1.10 \cos(2.30 t)$ e.) 0.761 m f.) $v = -2.53 \sin(2.30 t)$ g.) -1.83 m/s h.) $a = -5.83 \cos(2.30 t)$
05. i.) -4.03 m/s^2 **06.** 9.85 m/s^2 **07.** a.) no effect b.) no effect c.) 2 x greater

Simple Harmonic Motion & Waves

Simple Harmonic Motion-Review

Homework # 61

II

01. A vertical spring with a spring constant of 58.7 N/m has a 320.0-g mass hanging from it and is vibrating with an amplitude of 26.3 cm. Assume a stopwatch begins timing when the mass is at the amplitude.
- Write an equation describing the position of this mass as a function of time.
 - At what times will the mass be at a maximum displacement?
 - At what times will the mass be at minimum displacement?
 - At which time after the start of the clock will the mass be 17.5 cm from the equilibrium point?
02. Two springs are vibrating. The two springs have identical frequencies and masses. Spring 1 has exactly 16 times the energy of Spring 2. How do the amplitudes of these two springs compare?
03. A 750-g mass is hung from a vertical spring causing it to stretch 26.25 cm. The mass is then stretched an additional 12.00 cm and released just as a stopwatch is started.
- What is the spring constant?
 - What is the frequency of the vibration?
 - What is the maximum velocity of the mass?
 - What is the **TOTAL** energy of this system?
 - What is the velocity of the mass when it is 7.00 cm from the equilibrium point?
 - What are the elastic **AND** kinetic energies when the mass is 7.00 cm from the equilibrium point?
 - Write an equation that describes the position of **THIS** mass as a function of time.
 - What is the position of this mass after 12.0 s?
 - Write an equation that describes the velocity of **THIS** mass as a function of time.
 - What is the velocity of this mass after 12.0 s?
 - Write an equation that describes the acceleration of **THIS** mass as a function of time.
 - What is the acceleration of this mass after 12.0 s?
04. The displacement of a 1.65-kg mass on the end of a vibrating spring can be described by $x = (0.485 \text{ meters}) \sin(3.92t)$.
- What is the amplitude of this vibration?
 - What is the frequency of this vibration?
 - What is the maximum velocity of this vibrating mass?
 - What is the spring constant?
 - What is the **TOTAL** energy of this system?
05. A 1.75-meter long pendulum whose bob has a mass of 2.30 kg is pulled back 0.450 meters and released.
- Determine the period of the pendulum.
 - By what factor would the period of the pendulum change if the mass were quadrupled?
 - By what factor would the period of the pendulum change if the length were increased by a factor of 16?
 - By what factor would the period of the pendulum change if the amplitude were quintupled?

ANSWERS: **01.** a.) $x = 0.263 \cos(13.5 t)$ b.) 0.232 s, 0.464 s, 0.696 s, etc. c.) 0.116 s, 0.348 s, 0.580 s, etc. d.) 0.0624 s, 0.294 s, etc. **02.** $A_1 = 4A_2$ **03.** a.) 28.0 N/m b.) 0.972 Hz c.) 0.733 m/s d.) 0.202 J **03.** e.) 0.596 m/s f.) EPE = 0.0686 J, KE = 0.133 J g.) $x = 0.120 \cos(6.11 t)$ h.) -5.82 cm **03.** I.) $v = -0.733 \sin(6.11 t)$ j.) 0.641 m/s k.) $a = -4.48 \cos(6.11 t)$ l.) 2.17 m/s² **04.** a.) 0.485 m **04.** b.) 0.624 Hz c.) 1.90 m/s d.) 25.4 N/m e.) 2.98 J **05.** a.) 2.66 s b.) no effect c.) 4 x d.) no effect

Simple Harmonic Motion & Waves

Simple Harmonic Motion-Graphical Analysis A

Homework #62

Position of an Oscillating Mass as a Function of Time

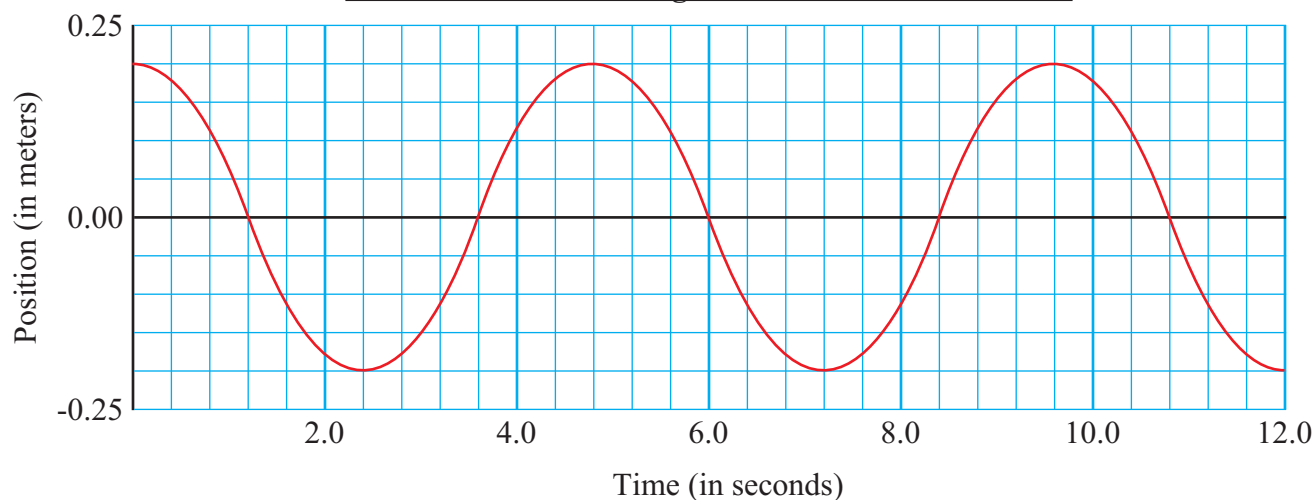

I

Use the graph above to answer each of the following questions.

01. What is the amplitude of this vibration?
02. What is the period of this vibration?
03. What is the frequency of this vibration?
04. What is the maximum velocity of this mass?
05. What is the velocity of this mass when it is 0.13 m from the equilibrium point?
06. Write an equation that describes the position of this vibrating mass as a function of time.
07. What will be the position of the mass at $t = 18.6$ s?
08. Write an equation that describes the velocity of this vibrating mass as a function of time.
09. What will be the velocity of the mass at $t = 18.6$ s?
10. Write an equation that describes the acceleration of this vibrating mass as a function of time.
11. What will be the acceleration of the mass at $t = 18.6$ s?

ANSWERS: **01.** 0.200 m **02.** 4.80 s **03.** 0.208 Hz **04.** 0.262 m/s **05.** 0.199 m/s
06. $x = 0.200 \cos(1.31 t)$ **07.** 0.141 m **08.** $v = -0.262 \sin(1.31 t)$ **09.** 0.185 m/s
10. $a = -0.343 \cos(1.31 t)$ **11.** -0.242 m/s^2

Simple Harmonic Motion & Waves

Simple Harmonic Motion-Graphical Analysis B

Homework #63

Position of an Oscillating Mass as a Function of Time

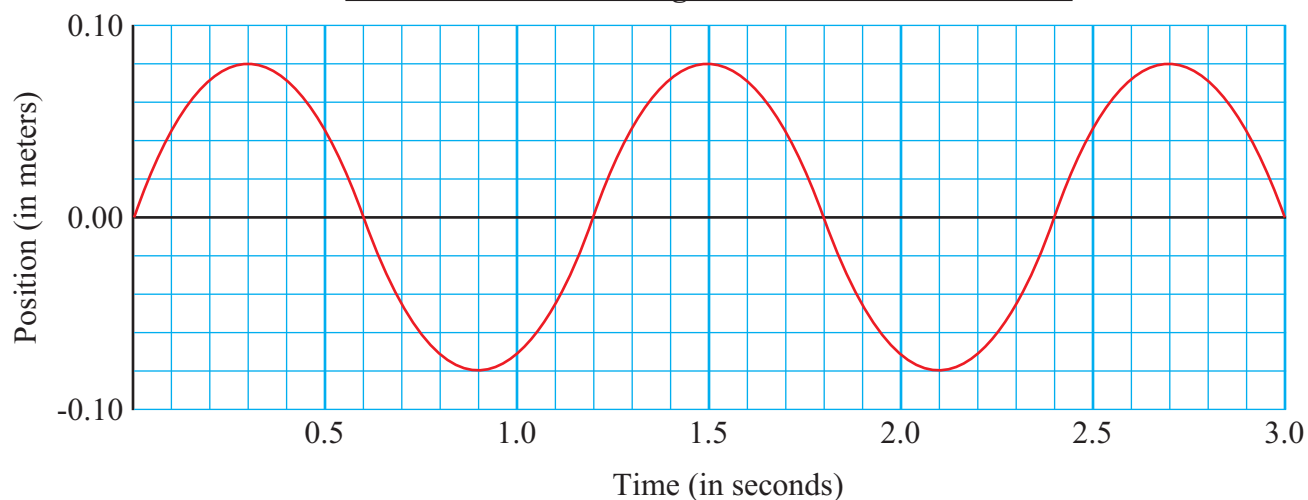

I

Use the graph above to answer each of the following questions.

01. What is the amplitude of this vibration?
02. What is the period of this vibration?
03. What is the frequency of this vibration?
04. What is the maximum velocity of this mass?
05. What is the velocity of this mass when it is 0.065 m from the equilibrium point?
06. Write an equation that describes the position of this vibrating mass as a function of time.
07. What will be the position of the mass at $t = 18.6$ s?
08. Write an equation that describes the velocity of this vibrating mass as a function of time.
09. What will be the velocity of the mass at $t = 18.6$ s?
10. Write an equation that describes the acceleration of this vibrating mass as a function of time.
11. What will be the acceleration of the mass at $t = 18.6$ s?

ANSWERS: **01.** 0.080 m **02.** 1.20 s **03.** 0.833 Hz **04.** 0.419 m/s **05.** 0.244 m/s
06. $x = 0.080 \sin(5.24 t)$ **07.** 0 m **08.** $v = 0.419 \cos(5.24 t)$ **09.** -0.419 m/s
10. $a = -2.19 \sin(5.24 t)$ **11.** 0 m/s²

Simple Harmonic Motion & Waves

Damped Harmonic Motion

Homework # 64

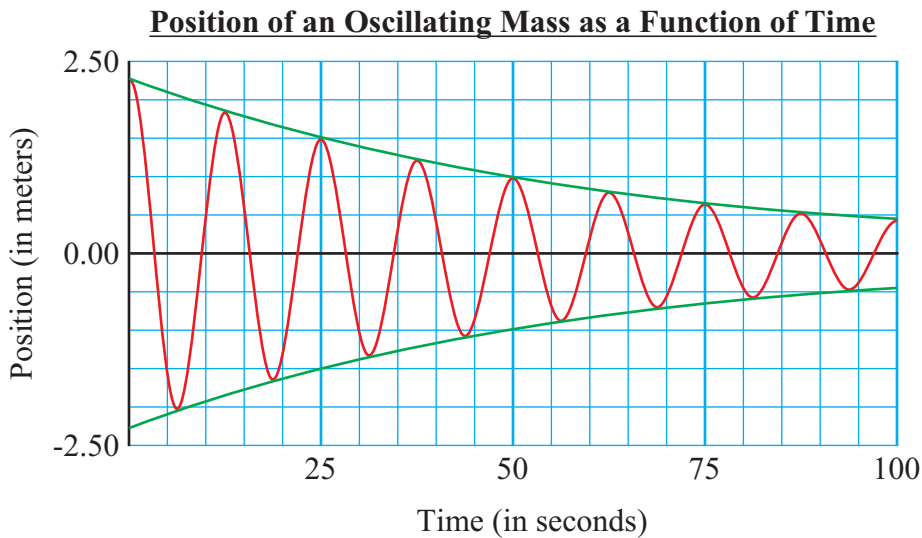

II

01. A 4545-kg (10,000-lb) wrecking ball on the end of a long cable attached to a crane is swinging back and forth. The graph above shows the position (from the natural rest position) of this swinging wrecking ball as a function of time (red line) and its amplitude as a function of time (green line).
- What is the period of the wrecking ball's vibration?
 - What is the length of the cable?
 - What is the initial amplitude of the wrecking ball's vibration?
 - Estimate the time constant.
 - Write an equation that will predict the amplitude of the wrecking ball as a function of time.
 - What will be the amplitude of the wrecking ball after 120 s?
 - How long will take the amplitude of the wrecking ball to be reduced to 1.00 cm?
 - How long will take the amplitude of the wrecking ball to be reduced to 1.00% of its initial value?
 - What is the frequency of the wrecking ball's vibration?
 - What is the wrecking ball's approximate maximum velocity during its first vibration?
 - What is the approximate energy of the wrecking ball during its first vibration?
 - Write an equation that will predict the energy of **THIS** vibrating system as a function of time.
 - What is the energy of the system after 50.0 s?
 - When will the energy be 1.00% of its initial value?
02. A damped harmonic system has an initial amplitude of 50.0 cm and a time constant of 10.00 s.
- What will be its amplitude after 35.00 s?
 - How long will take the amplitude to drop to 0.100% of its original value?
 - How long will it take the energy of the system to be 0.100% of its original value?

ANSWERS: **01.** a.) 12.5 s b.) 38.787 m c.) 2.25 m d.) 30.0 s e.) $A = (2.25 \text{ m})e^{-(t/30.0 \text{ s})}$ f.) 30.5 cm
01. g.) 325 s h.) 276 s i.) 0.0800 Hz j.) 1.13 m/s k.) 2907 J l.) $E = (2907 \text{ J})e^{-(t/30.0 \text{ s})}$ m.) 549 J
01. n.) 138 s **02.** a.) 8.68 cm b.) 138.2 s c.) 69.1 s

Simple Harmonic Motion & Waves

Wave Motion & Types of Waves

Homework # 65

Selected Physical Properties of Various Materials

<u>Material</u>	<u>Elastic Modulus</u> <u>E (N/m²)</u>	<u>Bulk Modulus</u> <u>B (N/m²)</u>	<u>Density</u> <u>ρ (kg/m³)</u>
Aluminum	70×10^9	70×10^9	2700
Brass	100×10^9	80×10^9	8560
Iron	100×10^9	40×10^9	7800
Steel	200×10^9	80×10^9	7800
Water		2.0×10^9	1000
Helium		1.01×10^5	0.179

I

01. A curious sailor with a stopwatch and a meter stick is looking at waves from the side of his anchored ship. He notices that the waves pass the bow every 4.35 s and the distance between the crests is 14.5 m. How fast are the waves moving?
02. Sound waves travel in air at 343 m/s on a particular day. How far apart are the compressions for a 383 Hz sound?
03. Electromagnetic waves (light) travel at 3.00×10^8 m/s. An AM radio station is granted a license to produce a carrier wave with an assigned frequency. These assigned frequencies range from 550 kHz to 1600 kHz. The FM frequencies range from 88 MHz to 108 MHz. [1 Megahertz (MHz) = 1×10^6 Hz = 1,000,000 Hz]
- What is the wavelength of the AM radio carrier wave with the lowest frequency?
 - What is the wavelength of the AM radio carrier wave with the highest frequency?
 - What is the wavelength of the FM radio carrier wave with the lowest frequency?
 - What is the wavelength of the FM radio carrier wave with the highest frequency?
04. What is the speed of a longitudinal wave in _____?
- water
 - aluminum

II

05. A rope with a mass of 675 g is stretched and tied tautly between two rigid poles that are 37.5 m apart. If the tension in the rope is 225 N, how long will it take a wave to travel from one end of the rope to the other?
06. What is the wavelength of a 12,000 Hz sound traveling along steel rod?
07. A deep-sea fisherman is pulling up his anchor (using a winch) out of the water. At the top, the anchor bangs against the side of the ship. Part of the sound wave produced travels to the ocean floor below and reflects (echos) back up to the ship 2.75 s later. How deep is the ocean at this location?

ANSWERS: **01.** 3.33 m/s **02.** 0.896 m/s **03.** a.) 545 m b.) 187.5 m c.) 3.41 m d.) 2.78 m
04. a.) 1414 m/s b.) 5092 m/s **05.** 0.335 s **06.** 0.422 m **07.** 1945 m

Simple Harmonic Motion & Waves

Energy of Waves & Refraction

Homework #66

I

01. Wave 1 on the ocean surface has twice the energy of Wave 2. What is the ratio of their amplitudes?
02. An earthquake wave traveling 8.25 km/s strikes a boundary where the earth changes to a different material. The direction of the wave in the first material makes a 26.0° angle with the boundary. If the direction of the wave in the second material changes to 36.5° with the boundary, what is the speed of the wave in the second medium?
03. The Atlantic Ocean's floor drops dramatically as you go from the coast of the Eastern United States eastward. This is known as the Continental Shelf. If water waves coming from the west toward the coastline approaches the shelf at 40.0° angle and is traveling at 2.80 m/s, what will be the angle of refraction if the wave travels 2.15 m/s in the shallow water?

II

04. Leaves on the surface of a pond move a total vertical distance of 24.00 cm between lowest and highest points as a wave passes through the pond.
- What is the amplitude of the wave?
 - By what factor would the energy of the wave change if the amplitude were reduced to 9.00 cm?
05. An earthquake passes through two towns. Town X is 20.0 km from the epicenter while town Y is 100.0 km from the epicenter.
- Compare the intensities, I_X to I_Y , as the earthquake passes through the respective towns.
 - If the intensity of the wave at town X was $2.5 \times 10^7 \text{ W/m}^2$, at what rate does energy pass through a person's property with an area of 1200.0 m^2 in town Y.
 - Compare the amplitudes, A_X to A_Y , as the earthquake passes through the respective towns.
06. Waves on the surface of water controlled by a dam have swells that are 0.640 m high and have an intensity of 64.5 W/m^2 . If the dam is 400 m wide, how much energy does it absorb each hour from the waves battering its face? Note: The height of a swell is the distance between the lowest and highest points of the wave (from trough to crest).
07. A longitudinal earthquake wave strikes a boundary between two types of rock at 38.5° angle. As it crosses the interface, the density of the rock changes from 3800 kg/m^3 to 2700 kg/m^3 , while the elastic modulus of the two rocks are similar. Calculate the angle of refraction.

ANSWERS: **01.** $A_1 = \sqrt{2}A_2$ **02.** 7.38 km/s **03.** 54.0° with the shelf edge (36.0° with normal to shelf edge)
04. a.) 12.0 cm b.) $E_2 = 0.563 E_1$ **05.** a.) $I_X = 25I_Y$ b.) $1.2 \times 10^9 \text{ W}$ c.) $A_X = 5A_Y$ **06.** $5.94 \times 10^7 \text{ J}$
07. 21.8° with the interface (68.2° with the normal to the interface)

Simple Harmonic Motion & Waves

Standing Waves & Two Point Sources of Waves

Homework #67

I

- If a violin string has a fundamental frequency of 294 Hz, what are its first four harmonics?
- A violin string vibrates at 440 Hz when unfingered. At what frequency will it vibrate when fingered one-fourth of the way down the neck?
- A standing wave is produced on a string tied between two supports with four loops by vibrating at 180 Hz. List the fundamental frequency and the next four harmonics.

II

- A standing wave on a string tied between two supports is created by vibrating the string at 380 Hz. If the speed of the waves is 240 m/s, how far apart are the _____?
 - nodes
 - antinodes
- If two successive overtones of a vibrating string are 660 Hz and 715 Hz, what is the frequency of the fundamental?
- A guitar string is 90.0 cm long and has a mass of 3.60 g. The string is "strung" on a guitar with a distance from the bridge to the support post of 60.0 cm. If the tension in the string is 520 N, what are the frequencies of the fundamental and first two overtones?
- A particular violin string vibrates at 440 Hz. If the tension in the string is increased by 12.5%, at what frequency will it now resonate?
- The electric company produces AC electricity with a frequency of 60.0 Hz which causes a tickertape timer plugged into an outlet to vibrate at this frequency. A 2.00-m long string with a mass of 3.15 g has one end attached to the vibrating mechanism of the timer with the rest of the string draped across a lab table, over a pulley on the far edge of the table and supporting a mass of $m = 200$ g. The position of the timer can be adjusted. How far from the pulley must the timer be located to produce three antinodes on the string? See diagram below and to the left.

- Two point sources are generating waves simultaneously as shown in the diagram (not drawn to scale) to the right. The wavelength of the waves produced is 1.60 cm and the distance between the two sources is 9.00 cm as shown.
 - At what angle will the third order antinode appear?
 - What will be the maximum order of the antinodes that these two sources can generate?

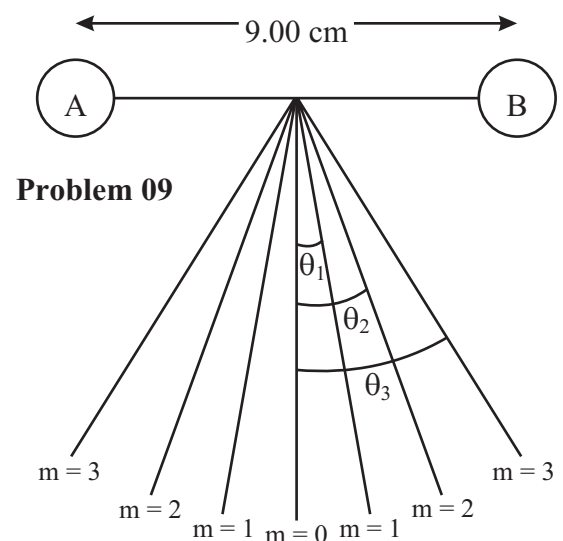
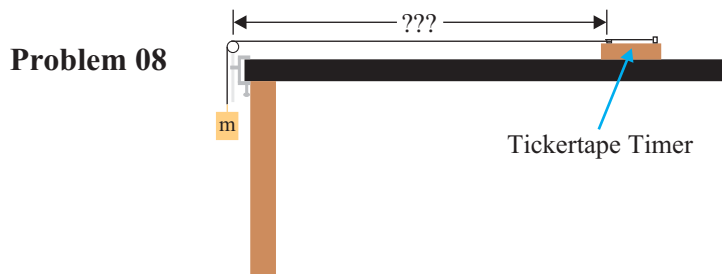

ANSWERS: **01.** $f_1 = 294$ Hz, $f_2 = 588$ Hz, $f_3 = 882$ Hz, $f_4 = 1176$ Hz **02.** 587 Hz
03. $f_1 = 45.0$ Hz, $f_2 = 90.0$ Hz, $f_3 = 135$ Hz, $f_4 = 180$ Hz **04.** a.) 0.316 m b.) 0.316 m
05. 55.0 Hz **06.** $f_1 = 300$ Hz, $f_2 = 600$ Hz, $f_3 = 900$ Hz **07.** 467 Hz **08.** 0.882 m **09.** a.) 32.2° b.) 5

Sound

Speed & Intensity of Sound

Homework # 68

I

01. A hiker, who is also an avid physics student, encounters a lake with a high cliff at the far border of the lake on a 20.0°C day. The student estimates the breadth of the lake by emitting a short shout and timing when the echo from the cliff is heard. If it takes 2.85 s for the echo to return, what is the breadth of the lake?
02. What is the intensity level of a sound wave whose intensity is $1.0 \times 10^{-7} \text{ W/m}^2$?
03. What is the intensity of a sound whose intensity level is 40 dB?

II

04. Studies indicate that humans can distinguish a difference of sound intensities of two sounds as small as about 1.0 dB.
 - a.) What is the ratio of the intensities of these two sounds?
 - b.) What is the ratio of the amplitudes of these two sounds?
05. A stereo tape recorder is rated to have a signal-to-noise ratio of 67 dB (in other words the signal, or music that is played, is 67 dB louder than the noise, or hissing, that the recorder inherently plays). What is the ratio of the intensities of the signal and the background noise?
06. If two firecrackers produce an intensity level of 95 dB at a certain distance away, what will be the intensity level at this location if only one firecracker were exploded at the same source location?
07. An 82-dB sound wave strikes an eardrum whose area is $4.5 \times 10^{-5} \text{ m}^2$.
 - a.) How much energy is absorbed by the eardrum per second?
 - b.) How much total energy is absorbed by the eardrum if the sound lasts 3.0 s?

III

08. A man jumps off a burning ship on a 25.0°C day and swims away. When the man is quite a distance away, he swims underwater to get past some small debris. While underwater he hears an explosion from the ship. He re-emerges to the surface and hears a second explosion 1.850 s after the first explosion. If the ship, indeed, only experienced one explosion, how far from the ship was the man when the ship exploded? (See [Homework #65](#) of "Simple Harmonic Motion" for Selected Physical Properties of Various Materials)
09. A person drops a stone from the top of a 10-story tall building onto the pavement below on a 20.0°C day. If the person hears the sound of the stone striking the pavement 3.34 s later, how tall is the building?

ANSWERS: **01.** 489 m **02.** 50 dB **03.** $1.0 \times 10^{-8} \text{ W/m}^2$ **04.** a.) 1.26 b.) 1.12 **05.** 5.01×10^6
06. 92 dB **07.** a.) $7.13 \times 10^{-9} \text{ J/s}$ b.) $2.14 \times 10^{-8} \text{ J}$ **08.** 847 m **9.** 50.0 m

Sound

Sources of Sound: Vibrating Strings & Air Columns Homework #69

I

- The G string on a violin has a fundamental frequency of 196 Hz. The length of the vibrating portion is 32.0 cm. Where must this G string be fingered such that it will vibrate with a fundamental frequency of 261 Hz?
- A guitar string is 65.0 cm long and has a mass of 4.60 g and is tuned to play low B (247 Hz).
 - Under what tension must the string be placed to achieve the desired sound (frequency)?
 - How far from the end of the string must the finger be placed to play E above middle C (329 Hz)?
- An organ pipe is 70.0 cm long. On a 20.0°C, what are the fundamental and first two overtones if the pipe is _____?
 - closed at one end
 - open at both ends
- A flute is designed to play middle C (264 Hz) as the fundamental frequency when all the holes are covered at 20.0°C.
 - Approximately how long should the distance be from the mouthpiece to the far end of the flute?
 - How far from the end should the hole be that must be uncovered to play D above middle C (440 Hz)?
- Determine the length of a closed organ pipe that emits middle C (262 Hz) when the temperature is 15.0°C?

II

- An organ is in tune at 20.0°C. By what fraction will the frequency be off at 0.0°C?
- An open organ pipe is to have a fundamental frequency of 262 Hz at 20.0°C.
 - How long must the pipe be to produce this sound?
 - What would be the fundamental frequency if it were filled with helium? (See [Homework #65](#) of "Simple Harmonic Motion" for Selected Physical Properties of Various Materials)
- A pipe in air at 20.0°C produces two successive harmonics at 240 Hz and 280 Hz.
 - Is it an open or closed tube?
 - What must be the length of this tube?
- A long, vertical tube is filled with water to the top on a 20.0°C day. A tuning fork is held over the mouth of the tube and the water is slowly lowered by draining water out of a hole in the bottom of the tube. (The level of the water in the tube can be controlled via a clamp attached to rubber tubing connected to the hole in the bottom of the tube.) When the water is 16.7 cm below the top of the tube the volume of the sound suddenly gets significantly louder. You continue lowering the water level in the tube until the sound again gets significantly louder. See diagram to the right.
 - What is the water level in the tube now?
 - What is the frequency of the tuning fork?

Hint: Changing the water level changes the length of the column (tube) of air above the water level. The sound wave resonates in this column of air. The water creates a barrier so this is a closed tube of air.

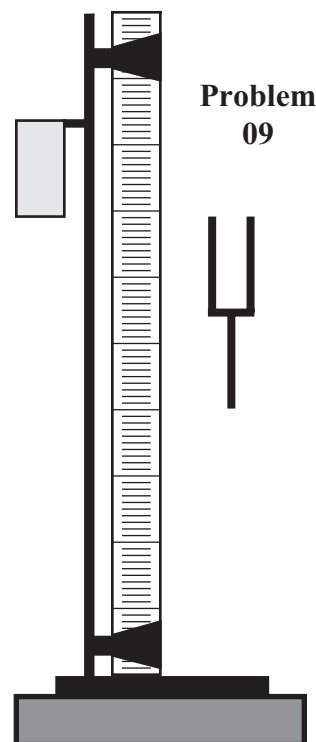

ANSWERS: **01.** 8.0 cm (24.0 cm) **02.** a.) 730 N b.) 16.2 cm (48.8 cm) **03.** a.) 122.5 Hz, 367.5 Hz, 612.5 Hz
03. b.) 245 Hz, 490 Hz, 735 Hz **04.** a.) 0.650 m b.) 0.26 m (0.39 m) **05.** 0.324 m **06.** 0.0350
07. a.) 0.655 m b.) 1.44 m **08.** a.) open b.) 4.30 m **09.** a.) 50.2 cm b.) 512 Hz

Sound

Wave Beats

Homework #70

I

01. Two horns emitting sounds of frequency 437 Hz and 441 Hz, respectively, produce beats of what frequency?
02. A piano tuner uses a tuning fork with a frequency of 330 Hz to tune a piano string. When he strikes the tuning fork and strikes the key of the piano that vibrates this string he notices a beat occurring every 1.50 s. How far off in frequency is the piano string?
03. Middle C (262 Hz) and C# (277 Hz) are played together.
- What will be the "beat frequency"?
 - What will be the "beat frequency" if both of these sounds are played two octaves lower (reduced by a factor of $2^2=4$)?

II

04. Two violin strings are tuned to the same frequency of 294 Hz. The tension in one string is increased by 7.00%. If the two strings are now played together, what will be the frequency of the beats?
05. Two piano strings, string A and String B, are supposed to be vibrating at 132 Hz, but a piano tuner hears a beat every 0.333 s when they are played simultaneously. Assume string A is correctly vibrating at 132 Hz.
- What are the possible frequencies of string B?
 - By what percent must the tension in string B be increased (or decreased) to bring them in tune?
06. Two identical flutes each tuned to play middle C (262 Hz) at 20.0°C. One is playing in a room that is 20.0°C while the other is playing from just inside of a walk-in freezer (with the door open) with a temperature of 0.0°C. An observer is in the room at a location that is between the two flutes. What frequency of beats will the observer detect. Ignore any difference in the speed of sound between the flutes AFTER the sound waves leave each flute (but the air inside the flutes is considered to be the at the temperature of their respective environments).
07. Two loud speakers are 3.20 m apart with an observer standing 3.40 m from the one speaker and 4.10 m from the other speaker in a large open field. The loudspeakers are connected to a wave generator that can vary the frequency of the monotone sound wave produced by the speakers. Assume the waves are in phase when they leave the speakers and the temperature of the air is a constant. The diagram to the right shows a top view of this field and indicates the relative orientation of the speakers and the observer. Ignore any reflections of the sound waves off the ground or any other object.
- What is the longest wavelength at which constructive interference will occur?
 - What is the longest wavelength at which destructive interference will occur?
08. A source emits a sound of wavelengths 3.15 m and 3.50 m in air at 20.0°C.
- How many beats per second will be heard?
 - How far apart from one another in space are the regions of maximum intensity?

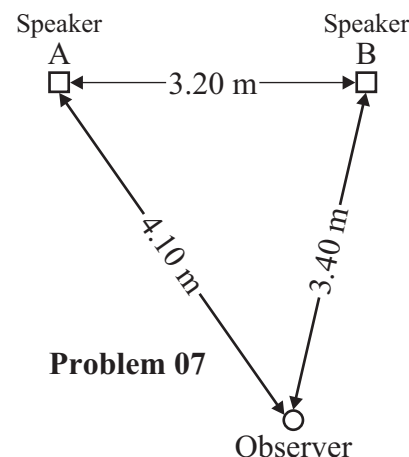

ANSWERS: **01.** 4 Hz **02.** 0.667 Hz **03.** a.) 15 Hz b.) 3.75 Hz **04.** 10.1 Hz
05. a.) 129 Hz, 135 Hz b.) 4.71% (4.40%) **06.** 9.17 Hz **07.** a.) 0.70 m b.) 1.40 m
08. a.) 10.9 Hz b.) 31.5 m

Sound

Doppler Effect

Homework #71

Note: Unless Otherwise stated, assume the temperature, T, is 20.0°C.

I

01. The predominant frequency of a certain police car's siren is 1650 Hz when at rest. What frequency would an observer detect if the car were moving at 30.0 m/s _____ the observer.
a.) toward _____ b.) away _____
02. A firehouse public alarm whistle emits a sound of 1250 Hz. What frequency would an observer detect if the observer were in a car moving at 45.0 km/h _____ the alarm.
a.) toward _____ b.) away _____

II

03. Two trains emit whistles with identical frequencies of 465 Hz. One train is at rest while the other is moving at 35.0 km/h away from an observer standing near the tracks on a 25.0°C. What beat frequency will the observer detect?
04. One of the uses of sonar is to detect the movement of the chest of a fetus. Sound waves with a frequency of 1.00×10^6 Hz are directed at the chest of a fetus. These waves travel through the body of the mother at a speed of 1500 m/s. What will be the maximum expected shift in frequency if the chest of a normal fetus moves at a maximum speed of 0.10 m/s? Hint: The sonar waves reflect off the chest of the fetus making his chest the source of the wave-it is the source of the wave that is moving, not the observer.
05. A police radar gun which operates at a frequency of 15 GHz (1 GHz-gigahertz = 1×10^9 Hz) is mounted in a police car that is traveling at 40.0 km/h down a long straight road. The radar is pointed at a car traveling at 70.0 km/h towards the police car. What will be the frequency of the beats detected by the radar system (these beats are created by the interference of the transmitted signal and the reflected wave)? Hint: When the radar waves reflect off the oncoming car, that car becomes the source of the waves and the police car's radar system is the observer.

ANSWERS: **01.** a.) 1808 Hz b.) 1517 Hz **02.** a.) 1296 Hz b.) 1204 Hz **03.** 13.4 Hz **04.** 66.7 Hz
05. 1.42 GHz = 1.42×10^9 Hz

Fluids & Kinetic Theory

Density

Homework #72

<u>Density of Substances</u>				
Substance	Density (ρ) (kg/m³)		Substance	Density (ρ) (kg/m³)
<i>Solids</i>			<i>Liquids</i>	
Aluminum	2.70 x 10 ³		Water	1.00 x 10 ³
Copper	8.92 x 10 ³		Blood, plasma	1.03 x 10 ³
Concrete	2.3 x 10 ³		Blood, whole	1.05 x 10 ³
Iron and Steel	7.85 x 10 ³		Ethyl Alcohol	0.79 x 10 ³
Gold	19.32 x 10 ³		Gasoline	0.68 x 10 ³
Ice	0.917 x 10 ³		Mercury	13.6 x 10 ³
Lead	11.30 x 10 ³		Sea Water	1.025 x 10 ³
Platinum	21.45 x 10 ³		Vegetable Oil	0.93 x 10 ³
Silver	10.49 x 10 ³			
Tin	7.31 x 10 ³		<i>Gases</i>	
Uranium	18.74 x 10 ³		Air	1.29
Zinc	7.14 x 10 ³		Carbon Dioxide	1.98
			Helium	0.179
			Steam (100°C)	0.598

I

01. What is the approximate mass of air in a classroom that is 12.50 m x 4.00 m x 5.10 m?
02. A wooden totem pole made of red cedar (SG = 0.380 kg/m³) has an approximate volume of 12.5 m³. What is its approximate mass?
03. A penny made in the United States in 1938 has a mass of 3.10 g and a diameter of 1.90 cm. What is the thickness of the penny?

II

04. A bottle has a mass of 46.75 g when empty and a mass of 104.32 g when filled to the brim with water. The water is emptied and the bottle is filled with an unknown fluid giving the bottle a fluid-filled mass of 92.23 g.
 - a.) What is the specific gravity (SG) of this fluid?
 - b.) What might this fluid be?
05. If 6.00 L of antifreeze (SG = 0.80) are added to 5.00 L of water, what is the SG of this 11.0-L mixture?

III

06. How much fresh water must be added to 12.5 L of sea water to produce a mixture with a SG of 1.018?

ANSWERS: 01. 329 kg **02.** 4750 kg **03.** 1.23 mm **04.** a.) 0.79 kg/m³ b.) ethyl alcohol **05.** 0.89
06. 4.86 L (results anywhere from 4.22 L to 5.6 L depend on rounding techniques)

Fluids & Kinetic Theory

Pressure & Pascal's Principle

Homework #73

I

01. The arm of a record player exerts a force on a record. This force is equivalent to a 1.00 g mass sitting directly on the stylus. If the stylus has a diameter of 0.0013 cm, calculate the pressure on the record groove in _____.
- a.) Pa b.) atm
02. A healthy value for diastolic blood pressure is 80.0 mm Hg. What would be the reading if measured in _____.
- a.) Pa b.) atm c.) torr
03. A physics teacher stands 1.88 m tall. What is the difference in blood pressure between the top of his head and the bottom of his feet when he is standing upright?
04. A lab desk has dimensions of 1.629 m in length by 0.610 m in width with a mass of 38.6 kg.
- a.) What is the total force acting on the top of the table from the atmosphere on an average day?
b.) Assuming the desk is not bolted to the floor, what is the total force need to lift this desk?
c.) Why is the answer to b.) less than c.)?

II

05. A cylindrical swimming pool with a diameter of 5.486 m is filled to a height of 1.220 m.
- a.) What is the total pressure at the bottom?
b.) What is the total force on the bottom?
c.) What is the total pressure on the side of the pool at the bottom?
d.) What is the total pressure on the side of the pool at the top?
e.) Estimate the total force on the side of the pool? (SA_{cylinder} is $2\pi rh$) Hint: Use average pressure to get total force.
06. Each of the four tires of a 1450-kg car have a gauge pressure of 221 kPa (32.0 lb/in²). How much area of each tire is in contact with the ground?
07. A rectangular-shaped bulkhead that is 72.0 m wide by 12.0 m high has water up to the top edge of the bulkhead.
- a.) What is the total force on the bulkhead if it is located in a fresh-water river?
b.) What is the total force on the bulkhead if it is located in a seaport?
08. The maximum gauge pressure in a hydraulic lift used in a auto-repair shop is 16.0 atm. If the output line has a diameter of 20.0 cm, what is the largest mass that it can lift?
09. How high would the level be in an ethyl alcohol barometer at normal atmospheric pressure?
10. Determine the minimum gauge pressure need in the water pipe leading into a building if it is to feed a faucet on the twelfth floor 30.0 m above.

III

11. A very long tube with a radius of 0.300 cm is placed in a tightly fitting hole in the top of wine barrel with a radius of 20.0 cm and filled to the lid with water. If water is filled in the tube to a height of 12.0 m the barrel bursts.
- a.) What is the mass of the water column in the tube? b.) What is the net force on the lid of the barrel?

ANSWERS: **01.** a.) 7.38×10^7 Pa b.) 731 atm **02.** a.) 10.6 kPa b.) 0.105 atm c.) 80.0 torr **03.** 19.3 kPa
04. a.) 100,363 N b.) 378 N c.) Same pressure on bottom **05.** a.) 113 kPa b.) 2.67×10^6 N c.) 113 kPa
05. d.) 101 kPa e.) 7.16×10^5 N **06.** 0.0110 m² **07.** a.) 1.38×10^8 N b.) 1.39×10^8 N **08.** 5180 kg
09. 13.0 m **10.** 2.94×10^5 Pa **11.** a.) 0.339 kg b.) 1.48×10^4 N

Fluids & Kinetic Theory

Buoyancy & Archimedes' Principle

Homework #74

Refer to the table on Density of Substances in [Homework #72](#) of this chapter.

I

01. A geologist finds a rock sample that has magnetic properties. He suspects that this sample is magnetite iron ore which has a density of 5046 kg/m^3 . He determines the mass of the rock to be 3.28 kg while its apparent mass is 2.63 kg when placed in water. What is the density of this rock? (Is it magnetite iron ore?)
02. What fraction of a piece of lead will be submerged when it floats in mercury?

II

03. A hydrometer is 32.0 cm in length and has a cross sectional area of 2.75 cm^2 and has a mass of 79.2 g .
- a.) How far from the end should this hydrometer have a marking 1.00 (the level to which it would sink in water)?
- b.) This hydrometer is placed in a sample of beer taken from a fermenting vat and sinks to a level of 29.2 cm . What is the density of the beer?

Problem 04

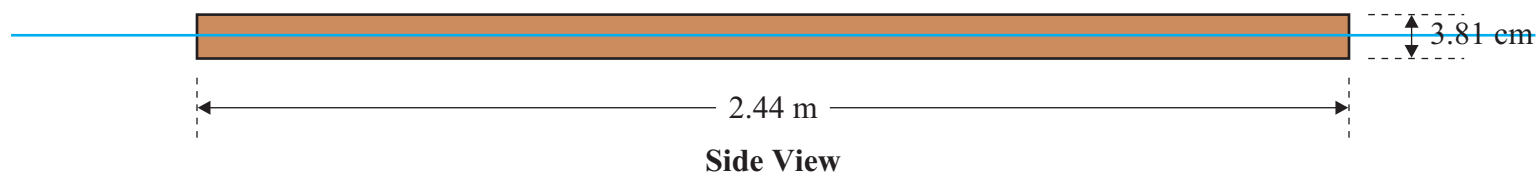

04. A 8 foot piece of $2'' \times 4''$ (actual dimensions are $1\frac{1}{2}'' \times 3\frac{1}{2}''$) lumber has metric dimensions of $2.44 \text{ m} \times 3.81 \text{ cm} \times 8.89 \text{ cm}$. When this 2-by-4 floats in water it naturally orients itself so that its center of mass is at its lowest possible level which is accomplished by having its biggest dimensions ($2.44 \text{ m} \times 8.89 \text{ cm}$) floating parallel to the surface of the water. If 1.79 cm of the remaining dimension is above water, what is the density of the lumber?
05. A 86.20-kg man has an effective mass of 3.99 kg when standing in sea water up to his neck. The SG of the human body is approximately 1.00 .
- a.) What is the mass of the portion of the body submerged?
- b.) What percentage of this man's total body weight is in his head?
- c.) Is this typical for a human male? See Homework #45 in the chapter called "Momentum" for the table named "Center of Mass of Parts of Typical Male Human Body."
06. An animal is placed in a vat of water to determine its density. Ethyl alcohol is slowly added until the animal is freely suspended. This occurs when there is 15.5 percent alcohol by weight and 84.5 percent water. What is the density of the animal?
07. A 0.925-kg piece of African mahogany floats in water but has an apparent mass of 0.039 kg when placed in ethyl alcohol. What is the SG of this piece of African mahogany?
08. What fraction of an iceberg is above the level of the sea water in which it is floating?

ANSWERS: **01.** 5046 kg/m^3 (yes) **02.** 0.831 **03.** a.) 28.8 cm b.) 986 kg/m^3 **04.** 530 kg/m^3
05. a.) 80.2 kg b.) 6.96% c.) yes **06.** 967 kg/m^3 **07.** 0.825 **08.** 0.105

Fluids & Kinetic Theory

Thermal Expansion

Homework #76

Coefficients of Thermal Expansion at 20°C		
Material	Coefficient of Linear Expansion, α [(C°) ⁻¹]	Coefficient of Volume Expansion, β [(C°) ⁻¹]
<i>Solids</i>		
Aluminum	25 x 10 ⁻⁶	75 x 10 ⁻⁶
Brass	19 x 10 ⁻⁶	56 x 10 ⁻⁶
Concrete/Brick	≈12 x 10 ⁻⁶	≈36 x 10 ⁻⁶
Iron and Steel	12 x 10 ⁻⁶	35 x 10 ⁻⁶
Lead	29 x 10 ⁻⁶	87 x 10 ⁻⁶
Glass (Pyrex)	3 x 10 ⁻⁶	9 x 10 ⁻⁶
Glass (ordinary)	9 x 10 ⁻⁶	27 x 10 ⁻⁶
Quartz	0.4 x 10 ⁻⁶	1 x 10 ⁻⁶
<i>Liquids</i>		
Ethyl Alcohol		1100 x 10 ⁻⁶
Gasoline		950 x 10 ⁻⁶
Glycerin		500 x 10 ⁻⁶
Mercury		180 x 10 ⁻⁶
Water		210 x 10 ⁻⁶
<i>Gases</i>		
Air (and most other gases at atmospheric pressure)		3400 x 10 ⁻⁶

I

01. A concrete highway is built of slabs 15.0 m long. How wide should the expansion cracks between the slabs be to prevent buckling if the range of temperatures to which the highway may be exposed is -30.0°C to +50.0°C?

II

02. To make a secure fit, rivets that are larger than the rivet hole are often used by cooling the rivet (usually in dry ice) before it is placed in the hole. A steel rivet 2.385 cm in diameter is to be placed in a hole 2.382 cm in diameter. To what temperature must the rivet be cooled if it is to fit in the hole (at 20.0°C)?

03. If the density of mercury is 13,570 kg/m³ at 20.0°C, what will be its density at 85.0°C?

04. An ordinary glass is filled to the brim with 275.0 mL of water at 25.0°C. Approximately how much water will spill out if the temperature is increased by 40.0°C?

05. What will be the ΔV for an iron sphere with a diameter of 28.6 cm at 25.0°C if it is heated to 200.0°C?

III

06. Show that for an isotropic solid $\beta = 3\alpha$. Hint: Show that the volume change for a rectangular solid of dimensions $l_0 \times w_0 \times h_0$ is given by $\Delta V = 3\alpha \cdot l_0 w_0 h_0 \cdot \Delta T$ not $\Delta V = \alpha^3 \cdot l_0 w_0 h_0 \cdot \Delta T$.

ANSWERS: **01.** 1.44 cm **02.** -84.8°C **03.** 13,410 kg/m³ **04.** 2.31 mL **05.** 7.50 x 10⁻⁵ m³ (75.0 cm³)

Fluids & Kinetic Theory

The Gas Laws (Boyle's, Charles', Gay-Lussac's, Ideal) Homework #77

Refer to the table on Density of Substances in [Homework #72](#) of this chapter and [Periodic Table](#) in Documents.

I

01. A beaker of water contains 2.500 L of water.
a.) How many moles of water are present? b.) How many molecules of water are present?
02. When 12.5 m^3 of an ideal gas initially at STP is placed under a pressure of 3.75 atm the temperature of the gas rises to 28.6°C . What is its volume under these conditions?

03. What is the number of molecules/ m^3 of any ideal gas at STP?

II

04. Using the ideal gas law, calculate the density of nitrogen at STP.
05. What is the pressure inside a 26.5-L container holding 62.3 kg of Neon gas at 25.0°C ?
06. What is the volume of storage tank if the gauge pressure of 83.3 kg of argon is measured to be 3.68 atm at 25.0°C ?
07. What is the temperature of a sample of sulfur dioxide having a mass of 0.0108 kg and a gauge pressure reading of 0.550 atm in a steel container with a volume of 2485 mL?
08. A storage tank contains 28.4 kg of chlorine gas at an absolute pressure of 2.85 atm. What will be the pressure in the tank if the chlorine is replaced by an equal mass of carbon dioxide gas at a constant temperature?
09. A tank contains 24.3 kg of fluorine gas at a gauge pressure of 5.25 atm. What mass of helium gas would be required to replace the oxygen at the same temperature and produce a gauge pressure of 6.45 atm?
10. There is 12.45 mol of oxygen gas contained in a balloon at 34.6°C . The balloon is in an air-tight room in which the gauge pressure is adjusted to 0.400 atm.
a.) What is the volume of the gas?
b.) If the volume of the gas is cut in half while the gauge pressure is adjusted to 1.55 atm, what is the temperature?
11. A flexible-walled container filled with 27.5 L of oxygen gas at 20.0°C has an absolute pressure of 1.64 atm. What will the pressure of the gas be if it is compressed to 17.6 L and heated until its temperature reaches 56.2°C ?
12. A cubic box with a volume of $8.40 \times 10^{-3} \text{ m}^3$ is filled with air at atmospheric pressure and a temperature of 25.0°C . The box is sealed and heated to 185.0°C . What is the **NET** force on **EACH** side of the box?

III

13. A tire is filled with air at 20.0°C to a gauge pressure of 175 kPa. From heat produced by friction between the road surface and the tire during driving the temperature of the air in the tire is raised to 42.5°C . What fraction of the original air must be removed if the original gauge pressure of the tire (175 kPa) is to be restored?
14. An air bubble at the bottom of a lake 21.7 m deep has a volume of 1.46 cm^3 . If the temperature of the water at the bottom is 7.25°C and at the top is 17.08°C , what is the volume of the bubble as it reaches the surface?

ANSWERS: **01.** a.) 138.9 moles b.) 8.36×10^{25} molecules **02.** 3.68 atm **03.** 2.69×10^{25} molecules/ m^3
04. 1.25 kg/m^3 **05.** 289 kPa (2.85 atm) **06.** 10.9 m^3 **07.** 278 K (-5°C) **08.** 1.77 atm **09.** 3.05 kg
10. 0.225 m^3 b.) 280 K (7°C) **11.** 2.88 atm **12.** 375 N **13.** 0.0713 **14.** 4.68 cm^3

Fluids & Kinetic Theory

Kinetic Theory

Homework #78

Refer to [Periodic Table](#) in Documents.

I

01. Calculate the rms speed of helium atoms near the surface of the sun at a temperature of about 6000 K.
02. A tank contains 3.75 L of nitrogen molecules at STP.
- What is the average kinetic energy of these nitrogen molecules?
 - What is the total translational kinetic energy of these molecules?
03. A collection of twelve molecules have the following speeds given in arbitrary units at a certain moment in time: 3, 5, 2, 0, 8, 3, 10, 4, 2, 1, 7, and 3.
- What is the most probable speed?
 - Calculate mean speed of the group.
 - Calculate the rms speed of the group.
 - Construct a graph of the relative number of molecules vs. speed for this collection and label the locations of the most probable speed, the mean speed, and the rms speed.
04. A gas in a container is at 25.0°C.
- To what temperature must it be raised to double the v_{rms} of its molecules?
 - what would happen to the v_{rms} if the absolute temperature were to double?

II

05. If the pressure of a gas is doubled while its volume is held constant, by what factor does the rms speed change?
06. One storage tanks contains helium gas at STP. A second identical storage tank contains carbon dioxide at STP.
- What is the average kinetic energy of the helium gas?
 - What is the average kinetic energy of the carbon dioxide gas?
 - What is the v_{rms} of the helium gas?
 - What is the v_{rms} of the carbon dioxide gas?
07. Algebraically demonstrate that for a mixture of two gases at the same temperature, the ration of the rms speeds of the molecules is equal to the square root of the inverse ratio of their molecular masses.
08. Consider a container of a nitrogen at 0°C.
- Calculate the v_{rms} of a nitrogen molecule in this container.
 - Assuming essentially no collisions with other molecules, determine the maximum number of times per second a nitrogen molecule would traverse back and forth across aa 8.21-m long room.
09. Show that the Pressure P in a gas can be written as $P = \frac{1}{2}\rho v_{\text{rms}}^2$, where ρ is the density of the gas.

ANSWERS: **01.** 6114 m/s **02.** a.) 5.65×10^{-21} J b.) 1.28×10^4 J **03.** a.) 3 b.) 4 c.) 4.92
04. a.) 919°C (1192 K) b.) increase by $\sqrt{2}$ **05.** $\sqrt{2}$
06. a.) 5.65×10^{-21} J b.) 5.65×10^{-21} J c.) 1304 m/s d.) 393 m/s **08.** a.) 493 m/s b.) 30 x each way

Fluids & Kinetic Theory

Real Gases & Phase Diagrams

Homework #79

Diagram 1

Phase Diagram for Water (H_2O)

[Note: Scales are not linear]

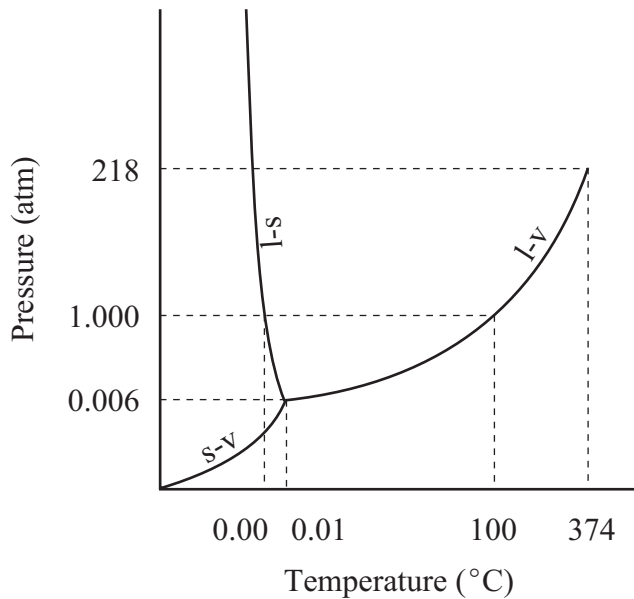
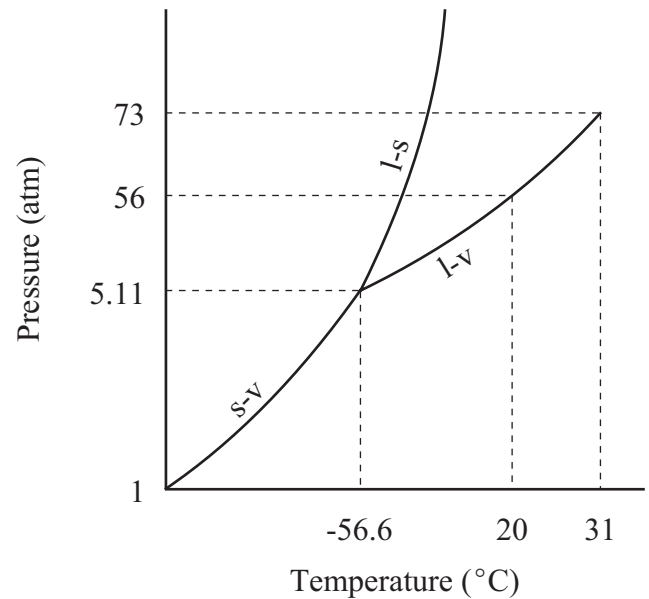

Diagram 2

Phase Diagram for Carbon Dioxide (CO_2)

[Note: Scales are not linear]



I

01. At normal atmospheric pressure, what phases can CO_2 exist?
02. For what range of temperatures can CO_2 be a liquid?
03. For what range of pressures can CO_2 be a liquid?
04. Which line represents the freezing point as a function of pressure in the CO_2 phase diagram?
05. Which line represents the boiling point as a function of pressure in the CO_2 phase diagram?
06. Which line represents the sublimation point as a function of pressure in the CO_2 phase diagram?
07. What is the triple point of CO_2 ?
08. What is the critical temperature of CO_2 ?
09. What is the critical pressure of CO_2 ?
10. What is the normal boiling point of H_2O ?
11. What is the normal freezing point of H_2O ?

ANSWERS: **01.** solid, vapor **02.** -56.6 $^{\circ}C$ to 31 $^{\circ}C$ **03.** 5.11 atm to 73 atm **04.** l-s **05.** l-v **06.** s-v
07. -56.6 $^{\circ}C$, 5.11 Pa **08.** 31 $^{\circ}C$ **09.** 73 atm **10.** 100 $^{\circ}C$ **11.** 0.0 $^{\circ}C$

Fluids & Kinetic Theory

Vapor Pressure & Humidity

Homework #80

<u>Saturated Vapor Pressure of Water</u>		
Temperature (°C)	Saturated Vapor Pressure	
	torr	Pa
-50	0.030	4.0
-10	1.95	2.60×10^2
0	4.58	6.11×10^2
5	6.54	8.72×10^2
10	9.21	1.23×10^3
15	12.8	1.71×10^3
20	17.5	2.33×10^3
25	23.8	3.17×10^3
30	31.8	4.24×10^3
40	55.3	7.37×10^3
50	92.5	1.23×10^4
60	149	1.99×10^4
70	234	3.12×10^4
80	355	4.73×10^4
90	526	7.01×10^4
100	760	1.01×10^5
120	1489	1.99×10^5
150	3570	4.76×10^5

I

01. What is the partial pressure of water in the air on a day when the temperature is 25.0°C and the relative humidity is 85.0%?
02. Approximately what is the dew point on a day with 60.0% humidity and a temperature of 25.0°C ?
03. At what approximate temperature does water boil at one location in the Andes where the air pressure is 0.692 atm?
04. What is the air pressure at a place in the Rockies where water boils at 80.0°C ?

II

05. A pressure cooker is half-filled with water before the lid is locked into place trapping some air above the water on a 25.0°C day. The pressure cooker is placed on a stove and heated until the water begins to boil. Assuming no escape of air, what is the approximate pressure inside the pressure cooker if the water is boiling at 120°C ?
06. If the humidity of a 520 m^3 room at 25.0°C is 80.0%, what mass of water must be removed to reduce the humidity to 50.0%?
07. If the relative humidity in a room with dimensions $4.65\text{ m} \times 7.28\text{ m} \times 9.45\text{ m}$ is 70.0% on a 20.0°C day, what mass of water can still evaporate from an open pan of water? Assume no loss of water out of this room.

ANSWERS: **01.** $2.69 \times 10^3\text{ Pa}$ (20.2 torr) **02.** 22°C **03.** 90°C **04.** $4.73 \times 10^4\text{ Pa}$ (355 torr)
05. $1.99 \times 10^5\text{ Pa}$ (1489 torr) **06.** 3.59 kg **07.** 1.65 kg

Fluids & Kinetic Theory

Fluids & Kinetic Theory Review

Homework #81

Refer to the table on Density of Substances in [Homework #72](#) of this chapter and [Periodic Table](#) in Documents.

II

01. A **CUBICLE** storage tank located outside a gas supply establishment in the open air (protected from human tampering by a chain link fence enclosure) contains 78.3 kg of carbon dioxide with a gauge pressure of 4.79 atm.
- What mass of sulfur dioxide would be needed to replace the carbon dioxide so as to increase the gauge pressure to 7.43 atm?
 - Assuming the storage tank has a volume of $12,300 \text{ cm}^3$, what is the net force that the carbon dioxide exerts on each side of the container?
 - What is the v_{rms} of a carbon dioxide molecule in that tank if the temperature is 25.0°C ?
 - What is the total translational kinetic energy of the carbon dioxide sample in the tank (Assume 25.0°C)?
02. A 32.70-kg object has an effective mass of 29.02 kg when placed in water.
- What is the specific gravity of this object?
 - Of what material is the object made?
03. Each tire on an 18-wheel, 14,000-kg tractor trailer truck is inflated to a gauge pressure of 300 kPa. How much area of each tire is in contact with the ground?
04. What is the relative humidity on a 30.0°C day if the dew point is 20.0°C ?
05. If 34.3 L of ammonia gas at a temperature of 23.6°C and a gauge pressure of 4.37 atm is heated until the gauge pressure reads 7.48 atm while the volume is allowed to increase to 42.7 L, what is the new temperature of this gas?
06. Water at a gauge pressure of 2.45 atm at street level enters a school at a speed of 0.775 m/s through a pipe with a diameter of 3.81 cm and proceeds up to the top floor 15.7 m above via a pipe that tapers down to 2.54 cm in diameter as it reaches the top floor. Ignoring viscosity, what is the _____ in the pipe on the top floor?
- flow velocity
 - gauge pressure

ANSWERS: **01.** a.) 166.1 kg b.) 25,780 N c.) 411 m/s d.) 6614 kJ ($6.614 \times 10^6 \text{ J}$)
02. a.) 8.9 b.) copper **03.** 0.019 m^2 (190 cm^2) **04.** 55.0% **05.** 310.0°C **06.** a.) 1.74 m/s b.) 0.915 atm

Heat & Thermodynamics

Homework #82

Specific Heats at 20°C and 1 atm (Constant Pressure)

Substance	Specific Heat, c		Substance	Specific Heat, c	
	kcal/kg·C°	J/kg·C°		kcal/kg·C°	J/kg·C°
<i>Solids</i>			<i>Liquids</i>		
Aluminum	0.22	900	Ethyl Alcohol	0.58	2400
Copper	0.093	390	Mercury	0.033	140
Glass	0.20	840	Human body (average)	0.83	3470
Iron and Steel	0.11	450	Protein	0.4	1700
Lead	0.031	130	Water		
Marble	0.21	860	Ice (-5°C)	0.50	2100
Silver	0.056	230	Liquid (15°C)	1.00	4180
Wood	0.4	1700	Steam (110°C)	0.48	2010

Latent Heats (at 1 atm)

Substance	Melting Point (°C)	Heat of Fusion		Boiling Point (°C)	Heat of Vaporization	
		kcal/kg	J/kg		kcal/kg	J/kg
Oxygen	-218.8	3.3	0.14×10^5	-183	51	2.1×10^5
Ethyl Alcohol	-114	25	1.04×10^5	78	204	8.5×10^5
Water	0	79.7	3.33×10^5	100	539	22.6×10^5
Lead	327	5.9	0.25×10^5	1750	208	8.7×10^5
Silver	961	21	0.88×10^5	2193	558	23×10^5
Tungsten	3410	44	1.84×10^5	5900	1150	48×10^5

Thermal Conductivities

Substance	Thermal Conductivity, k	
	kcal/s·m·C°	J/s·m·C°
Silver	10×10^{-2}	420
Copper	9.2×10^{-2}	380
Aluminum	5.0×10^{-2}	200
Steel	1.1×10^{-2}	40
Glass (typical)	2.0×10^{-4}	0.84
Concrete/Brick	2.0×10^{-4}	0.84
Water	1.4×10^{-4}	0.56
Human Tissue (excluding blood)	0.5×10^{-4}	0.2
Asbestos	0.4×10^{-4}	0.16
Wood	$0.2-0.4 \times 10^{-4}$	0.08-0.16
Cork and Glass Wool	0.1×10^{-4}	0.042
Down	0.06×10^{-4}	0.025
Air	0.055×10^{-4}	0.023

Heat & Thermodynamics

Heat, Specific Heat, & Calorimetry Problems

Homework #83

Refer to the table on Density of Substances in [Homework #72](#) of the chapter called "Fluids & Kinetic Theory".
Refer to the table on Specific Heats in [Homework #82](#) of this chapter.

I

01. How much heat is required to raise the temperature of 3.50 L of water from 15.0°C to 87.5°C?
02. A paddle wheel placed in a beaker of water is used to convert mechanical energy to thermal energy via the friction between the paddles and the water as in one of Joule's experiments. If 7250 J of work by the paddle wheel are converted to thermal energy of the water, what will be the temperature of the water if it started at 17.5°C?
03. A person eats a candy bar with 450 Cal. How much work must this person do to "burn" this intake of calories?
04. A 9.36-kg sample of an unknown metal requires 127 kJ of heat to raise the temperature from 22.7°C to 57.6°C.
a.) What is the specific heat of this metal? b.) What might this metal be?
05. The radiator of an automobile holds 15.5 L of water. How much heat does it absorb if its temperature rises from 25.0°C to 79.0°C?

II

06. What is the water equivalent of 18.25 kg of aluminum? (Water equivalent refers to the mass of water that would undergo the same temperature change when the same amount of heat is absorbed as the mass of the substance in question).
07. Water leaves the top of Niagara Falls at a speed of 4.25 m/s and falls 53.68 m to the bottom (water actually falls 21.35 m before hitting rocks, then traveling the remainder of the 53.68 m to the Niagara river at the bottom). Assuming all of the mechanical energy of the water is converted to heat at the bottom, what will be the increase in temperature of the water at the bottom?
08. The head of a hammer has a mass of 725 g and achieves a speed of 7.35 m/s just before striking a 12.6 g iron nail. If the hammer makes 8 identical blows to the nail in rapid succession, by how much will the temperature of the nail increase? Assume all of the mechanical energy of the hammer is absorbed as thermal energy by the nail.
09. A 32.5-g glass thermometer reads 19.5°C when it is placed in 235 mL of water. When thermal equilibrium between the water and the thermometer is achieved, the thermometer reads 51.3°C. What was the original temperature of the water? Assume no loss of heat to the environment.
10. A 194.7-g iron ingot at 236.7°C is placed in a 112-g aluminum calorimetry cup containing 325 mL of ethyl alcohol at 14.6°C. What will be the final temperature of the alcohol when thermal equilibrium is established among the alcohol, aluminum calorimetry cup, and iron ingot?
11. A 265.0-g block of copper is placed in a 140-g aluminum calorimetry cup containing 275 g of glycerin at an initial temperature of 12.4°C. If the final temperature is observed to be 36.8°C, what is the specific heat of glycerin?
12. How long will it take a 750-W coffee pot made of 450 g of aluminum to bring 811 mL of water at 11.1 °C to boil?

ANSWERS: **01.** 1.06×10^6 J **02.** 19.2°C **03.** 1.88×10^6 J **05.** a.) 390 J/kg•C° b.) copper **06.** 3.93 kg
07. 0.13°C **08.** 2.76°C **09.** 60.1°C **10.** 21.2°C **11.** 0.559 kcal/kg•C° (\approx 2300 J) **12.** 450 s (7.50 min)

Heat & Thermodynamics

Heat Transfer: Conduction, Convection, & Radiation Homework #85

Refer to the table on Thermal Conductivities in [Homework #82](#) of this chapter.

I

01. The windows in a house can be a major source of heat loss from the house. Because air is such a poor insulator, the layers of air on both the inner and outer surfaces of the window are at nearly the same temperature on a relatively calm day since the heat does not travel well to other parts of the room (on the inside) or away from the window (on the outside). On a windy day, this phenomenon does not occur as the outside layer is constantly replaced with fresh cool air. Calculate the rate of heat loss through a window 1.37 m x 0.76 m in area and 2.95 mm thick if the temperature at the inner surface is 16.5 °C and the temperature on the outer surface is _____.
- a.) 15.4 °C b.) -3.6 °C on a cold windy day
02. A tungsten sphere with a radius of 25.0 cm is at the room temperature of 23.6 °C. Tungsten has an emissivity of 0.35. The walls of the room are at a temperature of -4.2 °C.
- a.) How much power is radiated by the sphere to the room?
b.) What is the **NET** flow rate of energy from the sphere?
03. On a sunny day in the spring, the sun's rays make a 25° angle to the vertical. Approximately how much radiation does a person ($e = 0.80$) with a total surface area of 1.56 m² absorb each hour if he lies flat on his back?
04. In the human body, heat flows from the blood capillaries beneath the skin to the skin surface. On a normal day, an average of 200 W is transferred through the entire body's skin surface which has an area of 1.56 m². If the temperature difference between the blood capillaries and the skin surface is 0.525 °C, what is the thickness of the human tissue over which the heat must flow to reach the skin surface?

II

05. A 100-W light bulb generates 95 W of heat, which is dissipated through a glass bulb (approximating a spherical shape) with a radius of 3.00 cm and a thickness of 1.00 mm. What is the difference in temperature between the inner and outer surfaces?
06. A ceramic teapot ($e = 0.70$) and a shiny one ($e = 0.10$) each are filled to the brim with 750 mL of tea at 95.0 °C. The room in which the teapots sit is at 22.0 °C. Assume the teapots are nearly spherical in shape and answer the following considering only radiation losses.
- a.) What is the rate of heat loss from the ceramic teapot?
b.) What is the rate of heat loss from the shiny teapot?
c.) Estimate the temperature drop of the water in the ceramic teapot after 45 minutes. Assume only heat loss from water (ignore heat loss by the ceramic teapot).
d.) Estimate the temperature drop of the water in the ceramic teapot after 45 minutes. Assume only heat loss from water (ignore heat loss by the shiny teapot).

ANSWERS: **01.** a.) 326 J/s (0.0776 kcal/s) b.) 5959 J/s (1.42 kcal/s) **02.** a.) 121 W b.) 39.3 W
03. 1.90 x 10⁶ J **04.** 0.819 mm **05.** 10.0 °C **06.** a.) 29.06 J/s b.) 4.15 J/s c.) 25.0°C d.) 3.58°C

Heat & Thermodynamics

The First Law of Thermodynamics

Homework #86

I

01. One liter of air is cooled at a constant pressure (isobarically) until its volume is half of its original. Next, it is allowed to isothermally expand back to its original volume. Sketch the PV diagram for this process.
02. One liter of an ideal gas is cooled at a constant volume until it is at half its original pressure. This gas is then allowed to expand at constant temperature back to its original pressure. Sketch the PV diagram for this process.
03. An ideal gas is slowly compressed isothermally to half its original volume as 240 kcal of heat are removed.
 - a.) What is the change in internal energy of the gas?
 - b.) How much work was done during this process?

II

04. The latent heat of vaporization for water is 539 kcal/kg at 100 °C. One kilogram of steam occupies 1.67 m³ at 100 °C and 1 atm.
 - a.) How much work is done in converting 1.00 kg of water to steam at 100 °C and 1 atm?
 - b.) What is the change in internal energy when 1.00 kg of water is converted to steam at 100 °C and 1 atm?
 - c.) Use the ideal gas law to calculate the volume of 1.00 kg of steam at 100 °C and 1 atm.
 - d.) Why is the actual volume smaller than that predicted by the ideal gas law?
05. An ideal gas is allowed to expand adiabatically to twice its volume as it does 2340 J of work.
 - a.) How much heat is added to the system?
 - b.) What is the change in internal energy of the system?
 - c.) Did the temperature increase or decrease during this process?
06. A 290 mL ideal gas sample at 7.25 atm isobarically expands to 715 mL. The volume is then held constant as heat is slowly removed, reducing the pressure, until the temperature reaches its original value.
 - a.) What is the total work done by the gas?
 - b.) What is the total heat flow into the gas?

07. The graph at the right shows a cycle for 0.175 moles of an ideal gas. This gas has molar heat capacity values of $C_p = 19.10 \text{ J/K}\cdot\text{mol}$ and $C_v = 10.78 \text{ J/K}\cdot\text{mol}$.
 - a.) Calculate the temperature at points A, B, C, and D.
 - b.) Determine the change in temperature in stages AB, BC, CD, and DA.
 - c.) Determine the heat flow into the gas in stages AB, BC, CD, and DA.
 - d.) Determine the work done in stages AB, BC, CD, and DA.
 - e.) Determine the change in internal energy in stages AB, BC, CD, and DA.
 - f.) What is the **NET** heat flow in one cycle?
 - g.) What is the **NET** work done in one cycle?
 - h.) What is the **NET** change in internal energy in one cycle?

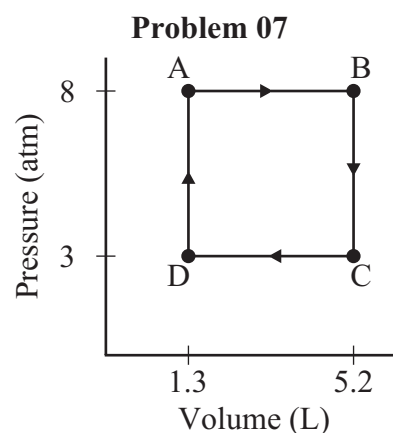

CONTINUED ON NEXT PAGE

ANSWERS: **03.** a.) 0 kcal b.) 240 kcal **04.** a.) $-1.69 \times 10^5 \text{ J}$ b.) $2.08 \times 10^6 \text{ J}$ c.) 1.70 m³
04. d.) intermolecular attractions **05.** 0J b.) -2340 J c.) Decrease **06.** a.) -312 J b.) 312 J
07. a.) $T_A = 724 \text{ K}$, $T_B = 2896 \text{ K}$, $T_C = 1086 \text{ K}$, $T_D = 271.5 \text{ K}$
07. b.) $\Delta T_{AB} = 2172 \text{ K}$, $\Delta T_{BC} = -1810 \text{ K}$, $\Delta T_{CD} = -814.5 \text{ K}$, $\Delta T_{DA} = 452.5 \text{ K}$
07. c.) $Q_{AB} = 7260 \text{ J}$, $Q_{BC} = -3415 \text{ J}$, $Q_{CD} = -2722 \text{ J}$, $Q_{DA} = 854 \text{ J}$
07. d.) $W_{AB} = -3161 \text{ J}$, $W_{BC} = 0 \text{ J}$, $W_{CD} = 1185 \text{ J}$, $W_{DA} = 0 \text{ J}$
07. e.) $\Delta U_{AB} = 4099 \text{ J}$, $\Delta U_{BC} = -3415 \text{ J}$, $\Delta U_{CD} = -1537 \text{ J}$, $\Delta U_{DA} = 854 \text{ J}$
07. f.) $Q_{ABCD} = 1977 \text{ J}$ g.) $W_{ABCD} = -1976 \text{ J}$ h.) $\Delta U_{ABCD} = 0 \text{ J}$ (actual = 1 J due to rounding)

Heat & Thermodynamics

The First Law of Thermodynamics

Homework #87

II

08. The graph at the right shows possible pathways for an ideal gas. For pathway AC, 120 J of heat leave the system and 65 J of work are done on the system. When the gas is taken along pathway CDA, the work done by the gas is $W_{CDA} = -42$ J. Assume $P_A = 2.5 P_D$.
- Determine the change in internal energy along pathway A to C.
 - Determine the heat added to the gas in process CDA.
 - How much work is done in process ABC?
 - What is Q for path ABC?
 - Determine Q for path BC if $\Delta U_{BA} = 25$ J.

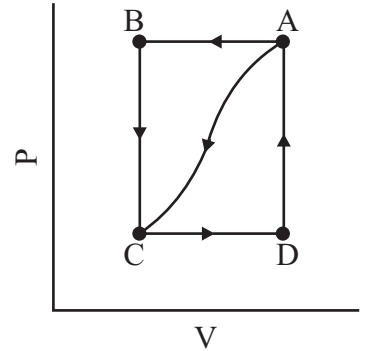

Problems 08 and 09

09. The graph at the top-right shows possible pathways for an ideal gas. For pathway AC, 72 J of heat leave the system and 47 J of work are done by the system. When the gas is taken along pathway ABC, the work done by the gas is $W_{ABC} = 34$ J. Assume $P_C = \frac{1}{2} P_B$.
- What is ΔU_{CA} ?
 - Determine the heat flow along pathway ABC.
 - Determine the work done by/on the gas in process CDA.
 - How much heat flow in process CDA?
 - Determine Q for path DA if $\Delta U_{CD} = 34$ J.

ANSWERS: **08.** a.) -55 J b.) 97 J c.) 105 J d.) -160 J e.) $Q_{BC} = -30$ J
09. a.) -119 J b.) -153 J c.) -17 J d.) 136 J e.) 85 J

Heat & Thermodynamics

The Second Law of Thermodynamics-Heat Engines/Refrigeration

Homework #88

I

01. An engine, whose operating temperatures are 685°C and 365°C , produces 7650 J of heat while performing 2650 J of useful work.
- What is the actual thermal efficiency of this engine?
 - What is the Carnot efficiency?
 - What is the second-law efficiency?
02. An engine has a Carnot efficiency of 35.0%. What is the operating temperature of this engine if the exhaust is measured to have a temperature of 335°C ?
03. What is the maximum efficiency of a heat engine whose operating temperatures are 480°C and 295°C ?

II

04. A heat engine that operates at a second-law efficiency of 60% operates between a temperature range of 680°C and 355°C while producing work at the rate of 2250 kW. How much heat is produced in a 40.0 minute period?
05. A Carnot engine performs work at the rate of 470 kW while absorbing 955 kcal of heat per second. If the temperature of the heat source is 660°C at what temperature is the waste heat exhausted?

06. The graph at the right shows a cycle for a simple heat engine that contains 0.1088 moles of an ideal gas. This gas has molar heat capacity values that have been determined to be $C_p = 20.14 \text{ J/K}\cdot\text{mol}$ and $C_v = 11.82 \text{ J/K}\cdot\text{mol}$.
- Determine the heat flow into the gas in stages AB, BC, CD, and DA.
 - What is the heat flow in during process DAB?
 - What is the heat flow in during process BCD?
 - Determine the work done in stages AB, BC, CD, and DA.
 - What is the **NET** work done in one cycle?
 - What is the thermal efficiency of this engine?
 - What is the **NET** heat flow in one cycle?
 - Determine the change in internal energy in stages AB, BC, CD, and DA.
 - What is the **NET** change in internal energy in one cycle?

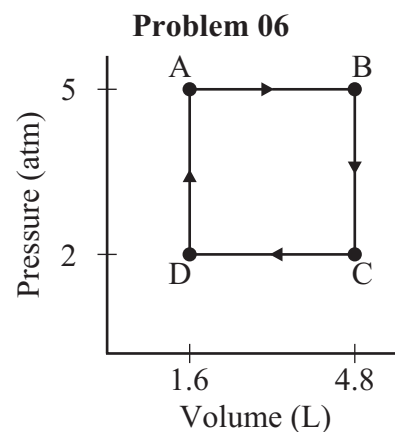

08. A refrigerator, rated at 260 W, removes 1950 kJ of heat in 25.0 minutes. What is the COP for this refrigerator?

III

07. Steam engines work in pairs at a steam power plant such that the heat output the first steam engine is the approximate heat source for the second steam engine. One steam power plant that produces 875 MW of power has operating temperatures of 740°C and 465°C in the first steam engine, and 455°C and 315°C in the second. Assume the efficiency of the engines is 65.0% of the ideal (Carnot) engine.
- At what rate must heat be provided to this system?
 - If coal has a heat of combustion of $2.8 \times 10^7 \text{ J/kg}$, at what rate must coal be burned to supply this system?

ANSWERS: **01.** a.) 25.7% b.) 33.4% c.) 77.0% **02.** 662°C **03.** 24.6% **04.** $2.10 \times 10^{10} \text{ J}$ **05.** 550°C
06. a.) $Q_{AB} = 3925 \text{ J}$, $Q_{BC} = -2074 \text{ J}$, $Q_{CD} = -1570 \text{ J}$, $Q_{DA} = 691 \text{ J}$ b.) $Q_{DAB} = 4617 \text{ J}$ c.) $Q_{BCD} = -3644 \text{ J}$
06. d.) $W_{AB} = -1621 \text{ J}$, $W_{BC} = 0 \text{ J}$, $W_{CD} = 648 \text{ J}$, $W_{DA} = 0 \text{ J}$ e.) $W_{ABCD} = -973 \text{ J}$ f.) 21.1%
06. g.) $Q_{ABCD} = 973 \text{ J}$ h.) $\Delta U_{AB} = 2305 \text{ J}$, $\Delta U_{BC} = -2074 \text{ J}$, $\Delta U_{CD} = -922 \text{ J}$, $\Delta U_{DA} = 691 \text{ J}$ i.) $\Delta U_{ABCD} = 0 \text{ J}$
07. 5.0 **08.** a.) $3.13 \times 10^9 \text{ J/s}$ b.) 112 kg/s

Heat & Thermodynamics

The Second Law of Thermodynamics-Entropy

Homework #89

I

01. What is the change in entropy of 22.6 kg of water at 0°C when it is frozen to ice at 0°C ?
02. What is the change in entropy of 3.33 kg of water at 100°C when it is vaporized to steam at 100°C ?
03. One kilogram of water is heated from its freezing point, 0°C to its boiling point, 100°C . Calculate the **APPROXIMATE** change in entropy of the water in the process.

II

04. A bucket containing 18.3 kg of water at 0°C is dumped onto a frozen lake with an extremely large quantity of ice at -10°C . Eventually, thermal equilibrium is established. Ignore any heat transfers with the air.
- What is the change in entropy of the water from the bucket?
 - What is the change in entropy of the ice on the lake?
 - What is the total change in entropy of the universe?
 - Is this process spontaneous?
05. One end of an steel rod is placed in molten lava at 825°C , while the other end of the rod is placed in a large nearby lake at 15.6°C . The rate at which the rod conducts heat from the lava to the lake is 7.32 cal/s . What is the entropy of the universe in this process? [Note: The melting point of steel is around 1370°C .]
06. One kilogram of water at 25.0°C is mixed with 1 kg of water at 85.0°C in a well-insulated container. Calculate the approximate change in entropy in the universe. (Is this spontaneous in nature?)
07. Four kilograms of water at 25.0°C is mixed with 1.50 kg of water at 85.0°C in a well-insulated container. Calculate the approximate change in entropy in the universe. (Is this spontaneous in nature?)
08. One kilogram of water at 25.0°C is mixed with 3.75 kg of water at 85.0°C in a well-insulated container. Calculate the approximate change in entropy in the universe. (Is this spontaneous in nature?)

III

09. A real heat engine working between heat reservoirs at 125°C and 425°C produces 600 J of work per cycle by absorbing 1800 J of heat at the hot reservoir.
- What is the actual efficiency of this real heat engine?
 - What is the Carnot efficiency of a heat engine working between these two reservoirs?
 - What is the second law efficiency of this real heat engine?
 - Calculate the total entropy change of the universe per cycle for this real heat engine?
 - Calculate the total entropy change of the universe per cycle of a Carnot engine working between these two reservoirs?

ANSWERS: **01.** -27.6 kJ/K **02.** 20.2 kJ/K **03.** 1294 J/K **04.** a.) -23.8 kJ/K b.) 24.6 kJ/K c.) 1.1 kJ/K
04. d.) yes ($\Delta S_{\text{univ}} > 0$) **05.** 0.106 J/s **06.** 35.0 J/K (yes) **07.** 85.0 J/K (yes) **08.** 54.0 J/K (yes)
09. a.) 33.3% b.) 43.0% c.) 77.6% d.) 0.436 J/K e.) 0 J/K

Heat & Thermodynamics

The First Law of Thermodynamic-Review

Homework #90

Questions 01-06 refer to the diagram to the right which describes 5.50 moles of a monatomic ideal gas with specific heats of $C_V = 12.472 \text{ J/mol}\cdot\text{K}$ and $C_P = 20.786 \text{ J/mol}\cdot\text{K}$ used in the operation of an ideal internal combustion engine.

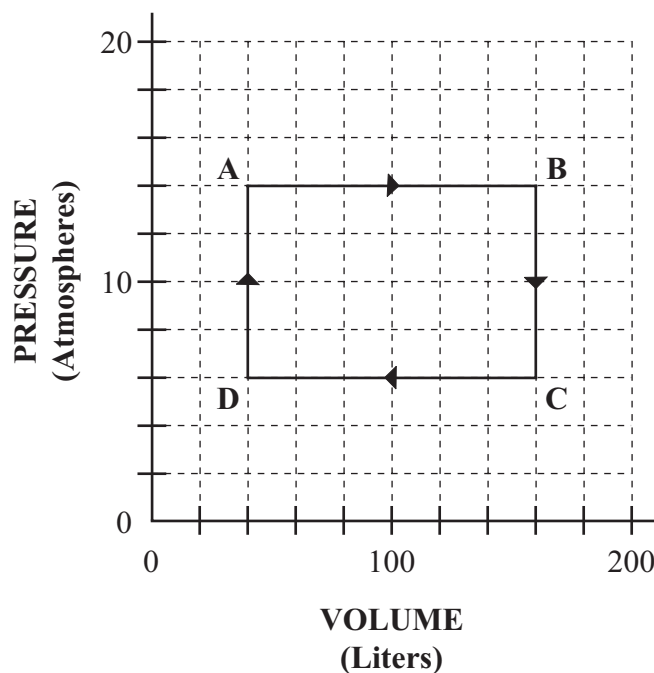

01. Determine how much work was done during each of the following pathways.
- AB
 - BC
 - CD
 - DA
 - ABCD
02. Determine the temperature of this sample of gas at each of the following points.
- A
 - B
 - C
 - D
03. Determine how much heat was put in (+) or taken out (-) during each of the following pathways.
- AB
 - BC
 - CD
 - DA
 - BCD
 - DAB
 - ABCD
 - How much heat was added to the system during one cycle?
 - How much heat was emitted from the system during one cycle?
 - What was the net heat flow during one cycle?
04. Determine how much internal energy this sample of gas has at each of the following points.
- A
 - B
 - C
 - D
05. Using two different methods for each of the following pathways, determine the change in internal energy of this sample.
- AB
 - BC
 - CD
 - DA
 - AC
 - BD
 - CA
 - DB
 - ABC
 - BCD
 - CDA
 - DAB
 - CBA
 - DCB
 - ADC
 - BAD
 - ABCD
 - BCDAB
 - CDABC
 - DABCD
 - DCBAD
 - CBADC
 - BADCB
 - ADCBA
06. What is the thermal efficiency of this heat engine?

- | | | | | |
|---------------------------------------|-----------------------------------|-----------------------------------|-----------------------------------|-----------------------------------|
| 01. a.) -170,100 J | b.) 0 J | c.) 72,900 J | d.) 0 J | e.) -97,200 J |
| 02. a.) 1240 K | b.) 4962 K | c.) 2126 K | d.) 532 K | |
| 03. a.) $4.25 \times 10^5 \text{ J}$ | b.) $-1.94 \times 10^5 \text{ J}$ | c.) $-1.82 \times 10^5 \text{ J}$ | d.) $4.86 \times 10^4 \text{ J}$ | e.) $-3.77 \times 10^5 \text{ J}$ |
| 03. f.) $4.74 \times 10^5 \text{ J}$ | g.) $9.72 \times 10^4 \text{ J}$ | h.) $4.74 \times 10^5 \text{ J}$ | i.) $-3.77 \times 10^5 \text{ J}$ | j.) $9.72 \times 10^4 \text{ J}$ |
| 04. a.) $8.51 \times 10^4 \text{ J}$ | b.) $3.40 \times 10^5 \text{ J}$ | c.) $1.46 \times 10^5 \text{ J}$ | d.) $3.65 \times 10^4 \text{ J}$ | |
| 05. a.) $2.55 \times 10^5 \text{ J}$ | b.) $-1.94 \times 10^5 \text{ J}$ | c.) $-1.09 \times 10^5 \text{ J}$ | d.) $4.86 \times 10^4 \text{ J}$ | e.) $6.10 \times 10^4 \text{ J}$ |
| 05. f.) $-3.03 \times 10^5 \text{ J}$ | g.) $-6.10 \times 10^4 \text{ J}$ | h.) $3.03 \times 10^5 \text{ J}$ | i.) $6.10 \times 10^4 \text{ J}$ | j.) $-3.03 \times 10^5 \text{ J}$ |
| 05. k.) $-6.10 \times 10^4 \text{ J}$ | l.) $3.03 \times 10^5 \text{ J}$ | m.) $-6.10 \times 10^4 \text{ J}$ | n.) $3.03 \times 10^5 \text{ J}$ | o.) $6.10 \times 10^4 \text{ J}$ |
| 05. p.) $-3.03 \times 10^5 \text{ J}$ | q.) 0 J | r.) 0 J | s.) 0 J | t.) 0 J |
| 05. u.) 0 J | v.) 0 J | w.) 0 J | x.) 0 J | 06. 20.5% |

Heat & Thermodynamics

The Second Law of Thermodynamics-Review

Homework #91

The PV diagram to the right represents the states of an ideal gas during one cycle of operation of a reversible heat engine. The cycle consists of four processes. As shown on the diagram, 1500 J of heat enters the system during the isothermal process AB.

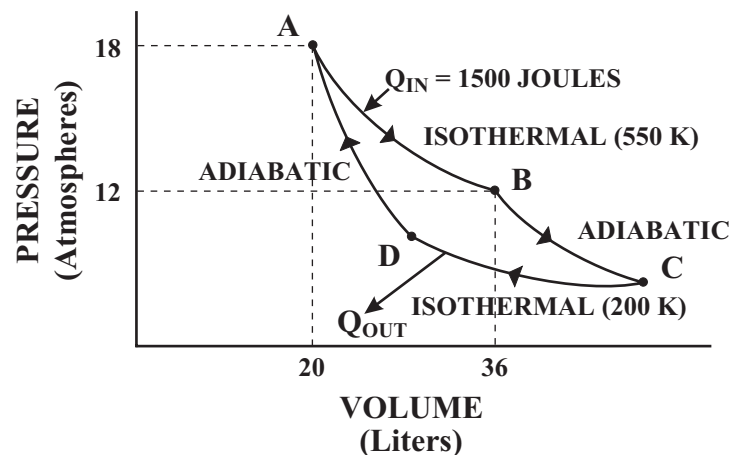

01. What will be the change in the internal energy of the gas during the process AB?

02. How much work is done by this gas during the process AB?

03. What will be the thermal efficiency of this system during one complete cycle?

04. How much heat, Q_{out} , will be exhausted during process CD?

05. What will be the **NET** work done by this system during each complete cycle?

06. How much heat will be absorbed by this system during the process DA?

07. How will the thermal energy of this gas at state C compare with the internal energy at state D?

01. 0 J 02. -1500 J 03. 63.6% 04. 546 J 05. -954 J 06. 0 J 07. 0 J

Electrostatics

Homework #92

Useful Information

Coulomb's constant for air, $k = 9.0 \times 10^9 \text{ N}\cdot\text{m}^2 / \text{C}^2$
permittivity of empty space, $\epsilon_0 = 8.85 \times 10^{-12} \text{ C}^2 / \text{N}\cdot\text{m}^2$
charge of an electron, $q_e = -1.6 \times 10^{-19} \text{ C}$
mass of an electron, $m_e = 9.11 \times 10^{-31} \text{ kg}$
charge of a proton, $q_p = +1.6 \times 10^{-19} \text{ C}$
mass of a proton, $m_p = 1.67 \times 10^{-27} \text{ kg}$

Dielectric Constants (at 20°C)

Material	Dielectric Constant, K
Vacuum	1.0000
Air (1 atm)	1.0006
Paraffin	2.2
Rubber, Hard	2.8
Vinyl (Plastic)	2.8 - 4.5
Paper	3 - 7
Quartz	4.3
Glass	4 - 7
Porcelain	6 - 8
Mica	7
Ethyl Alcohol	24
Water	80

Electrostatics

Coulomb's Law

Homework #93

See [Homework #92](#) for Useful Information such as mass and charge of a proton and an electron.

I

01. A pith ball has a surplus of 3.45×10^{14} electrons. What is the net charge on this ball?
02. How many electrons are needed to produce a charge of $-0.850 \mu\text{C}$?
03. An electroscope has 5.87×10^{16} more protons than electrons. What is the net charge on this electroscope?
04. Two charged bodies exert a force of 0.72 N on each other.
 - a.) What will be the force that each exerts on the other if they are moved so that they are six times as far apart?
 - a.) What will be the force that each exerts on the other if they are moved so that they are one-sixth as far apart?
05. A pith ball that has a residual charge of $-48.0 \mu\text{C}$ is placed in contact with a second identical pith that initially has a charge of $26 \mu\text{C}$. Charges will flow until an electrostatic equilibrium is reached.
 - a.) What will be the charge on each pith ball when this equilibrium is reached?
 - b.) How many extra electrons are on each pith ball when this equilibrium is reached?
06. A conducting sphere (Sphere A) has a residual charge of $+86 \mu\text{C}$ is placed in contact with a second conducting sphere (Sphere B) with twice the surface area and initially containing a residual charge of $-17 \mu\text{C}$. What is the charge on each sphere upon equilibrium?
07. What is the magnitude of the electrostatic force of attraction between an iron nucleus ($q = +26e$) and one of its innermost electrons at a distance of $1.50 \times 10^{-12} \text{ m}$.
08. What will be the magnitude of the electrostatic force between two pith balls 18 cm apart if one has a charge of $-37 \mu\text{C}$ and the other has a charge of $19 \mu\text{C}$?
09. What is the magnitude of the electrostatic force between two protons in the nucleus of an atom that are separated by a distance of $5.6 \times 10^{-15} \text{ m}$ (5.6 Fermi)?

II

10. Calculate the net electrostatic force (magnitude and direction) acting on the $-8.00 \mu\text{C}$ in each of the following arrangement of charges.

a.)



b.)

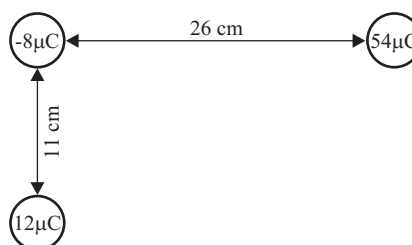

c.)

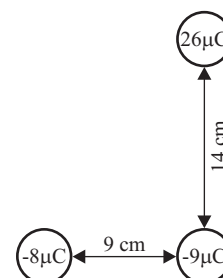

ANSWERS: **01.** $-5.52 \times 10^{-5} \text{ C}$ ($-55.2 \mu\text{C}$) **02.** 5.31×10^{12} **03.** $9.39 \times 10^{-3} \text{ C}$ (9.39 mC) **04.** a.) 0.02 N
04. b.) 25.92 N **05.** a.) $-11 \mu\text{C}$ b.) 6.88×10^{13} **06.** $+23 \mu\text{C}$, $+46 \mu\text{C}$ **07.** $2.66 \times 10^{-3} \text{ N}$ **08.** 195 N
09. 7.35 N **10.** a.) 101 N to the left b.) 91.7 N @ 51.1° below + x-axis c.) 71.6 N @ 52.6° above - x-axis

Electrostatics







Electric Fields-Point Sources

Homework #94

See [Homework #92](#) for Useful Information such as mass and charge of a proton and an electron.

I

01. Sketch the electric field lines for each of the following arrangements. Use 8 field lines per charge, q .

a.) 	b.) 
c.) 	d.) 
e.) 	

02. An electron is placed in a uniform electric field with a magnitude 2250 N/C.

- What is the magnitude of the force on the electron from this field?
- Describe the direction of this force relative to the direction of the electric field.
- What is the magnitude of the acceleration of the electron?

03. An proton is placed in a uniform electric field with a magnitude 2250 N/C.

- What is the magnitude of the force on the electron from this field?
- Describe the direction of this force relative to the direction of the electric field.
- What is the magnitude of the acceleration of the electron?

04. An electrostatic force of 2.94×10^{-3} N is exerted in an upward direction on a $0.735 \mu\text{C}$ charge. What is the magnitude and direction of the electric field at this point?

05. What is the charge on an object that experiences a force of 18.2 N when placed in an electric field of 1825 N/C?

ANSWERS: **02.** a.) 3.60×10^{-16} N b.) opposite c.) 3.95×10^{14} m/s²
03. a.) 3.60×10^{-16} N b.) same c.) 2.16×10^{11} m/s² **04.** 4000 N/C **05.** 9.97 mC

Electrostatics

Vector Nature of Electric Fields-Point Sources

Homework #95

See [Homework #92](#) for Useful Information such as mass and charge of a proton and an electron.

I

- Two charges of $+75.0 \mu\text{C}$ each are 6.00 cm apart. What is the **NET** electric field at a point midway between them?
- Two charges of $-75.0 \mu\text{C}$ each are 6.00 cm apart. What is the **NET** electric field at a point midway between them?
- Two equal but opposite charges of $75.0 \mu\text{C}$ are 6.00 cm apart. What is the **NET** electric field at a point midway between them?
- A charge of $+75.0 \mu\text{C}$ and $+150.0 \mu\text{C}$ are 6.00 cm apart. What is the **NET** electric field at a point along the line joining the them that is 2.00 cm from the $+75.0 \mu\text{C}$ and 4.00 cm from the $+150.0 \mu\text{C}$ charge?
- A charge of $+75.0 \mu\text{C}$ and $-150.0 \mu\text{C}$ are 6.00 cm apart. What is the **NET** electric field at a point along the line joining the them that is 2.00 cm from the $+75.0 \mu\text{C}$ and 4.00 cm from the $-150.0 \mu\text{C}$ charge?

II

- A charge of $+75.0 \mu\text{C}$ and $+150.0 \mu\text{C}$ are 6.00 cm apart. At what point in space is the **NET** electric field zero?
- A charge of $+75.0 \mu\text{C}$ and $-150.0 \mu\text{C}$ are 6.00 cm apart. At what point in space is the **NET** electric field zero?
- Three charges are placed at the corners of rectangle as shown to the right.
 - What is the **NET** electric field at point P?
 - What would the net force be on an alpha particle (helium nucleus) placed at point P?
 - What would be the acceleration of an alpha particle placed at point P?
- What is the acceleration of an electron in a 4200-N/C electric field?
- What is the electric field at a point in space where a proton experiences an acceleration of $7.85 \times 10^5 \text{ m/s}^2$?

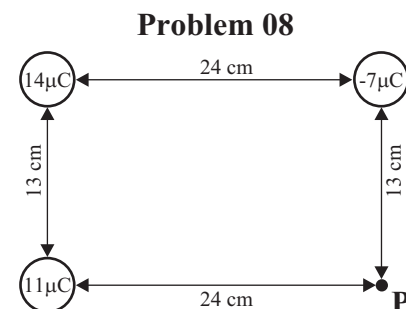

Problems 11 and 12 refer to the diagram to the right which shows three identical charges of Q are placed at the corners of an equilateral triangle with sides of l .

- Where is the **NET** electric field zero?
- If $Q = 9 \mu\text{C}$ and $l = 20.0 \text{ cm}$, what is the **NET** electric field at the origin?
- If a spaceship were to travel from the earth in a straight line to the moon ($380,000 \text{ km}$ away from earth), at what point along the trip would the **NET** gravitational field be zero? The mass of the moon is about $\frac{1}{81}$ that of the earth.

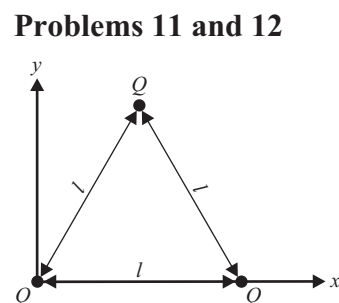

ANSWERS: **01.** 0 N/C **02.** 0 N/C **03.** $3.75 \times 10^8 \text{ N/C}$ twrd + chrg **04.** $8.44 \times 10^8 \text{ N/C}$ twrd +75 μC chrg
05. $2.53 \times 10^9 \text{ N/C}$ twrd + chrg **06.** 0.0249 m fr +75 μC chrg (0.0351 m fr 150 chrg) **07.** 0.145 m fr +75 μC chrg
08. a.) $4.34 \times 10^6 \text{ N/C}$ @ 42.4° above + x -axis b.) $1.38 \times 10^{-12} \text{ N}$ (same dir) c.) $2.09 \times 10^{14} \text{ m/s}^2$ (same dir)
09. $7.38 \times 10^{14} \text{ m/s}^2$ **10.** $8.19 \times 10^{-3} \text{ N/C}$ **11.** $(0.5l, 0.289l)$ **12.** $3.51 \times 10^6 \text{ N/C}$ @ 30° below - x -axis
13. $3.42 \times 10^8 \text{ m}$ from the earth ($0.38 \times 10^8 \text{ m}$ from the moon)

Electrostatics

Uniform Electric Fields-Two Plates

Homework #96

II

01. An oil drop with a mass of 2.45 g is suspended between two oppositely-charged plates that are 10.00 cm apart and have a potential difference of 6000 V as shown in the diagram to the right.
- Show the direction of the electric field on the diagram.
 - What is the magnitude of the electric field?
 - What is the force due to gravity acting on the oil drop?
 - What is the charge on the oil drop?
 - Show the equipotential lines for 1500 V, 3000 V, and 4500 V on the diagram.

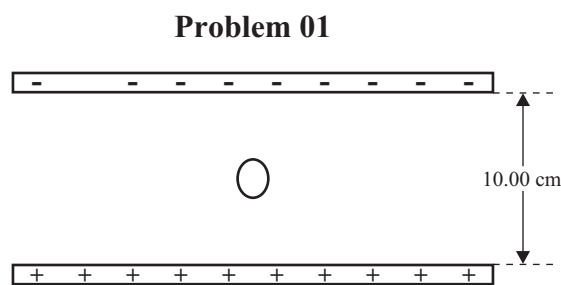

02. Another oil drop with a mass of 2.83 g is suspended between two oppositely-charged plates that are 5.00 cm apart and produce an electric field of 90,000 V/m as shown in the diagram to the right.
- Show the direction of the electric field on the diagram.
 - What is the potential difference between the plates?
 - What is the force due to gravity acting on the oil drop?
 - What is the charge on the oil drop?

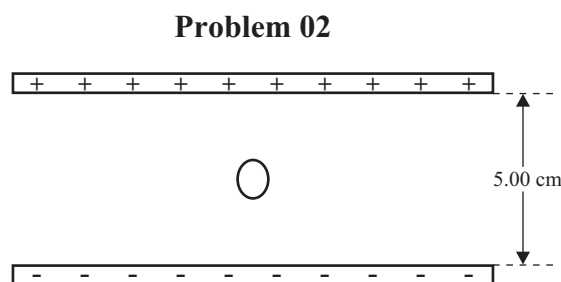

03. An electron traveling at 2.65×10^7 m/s enters an electric field created by two oppositely-charged plates that are 18.00 cm apart as shown in the diagram to the right. The potential difference between the two plates is 4500 V.
- What is the magnitude of the electric field between the plates?
 - What is the electrostatic force (magnitude and direction) on the electron when it enters the field?
 - What is the force of gravity acting on the electron?
 - What is the acceleration (magnitude and direction) that the electron experiences when it enters the field?

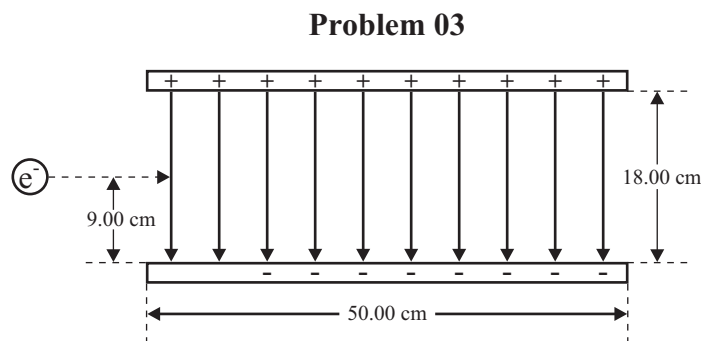

- How long will it take the electron to hit the positive plate?
- How far from the left edge of the positive plate will the electron hit this plate?
- If a proton entered this field what would be the acceleration (magnitude and direction) of the proton?

04. One end of a 24.0 cm long string is attached to a wall of positive charge producing a uniform electric field with a strength of 67,500 V/m. The other end is attached to a charged pith ball as shown in the diagram to the right. The electric field from the wall acts on the pith ball causing the string to make a 30.0° angle.
- What is the force of gravity acting on the pith ball?
 - What is the force of tension in the string?
 - What is the electrostatic force acting on the pith ball?
 - What is the charge on the pith ball?

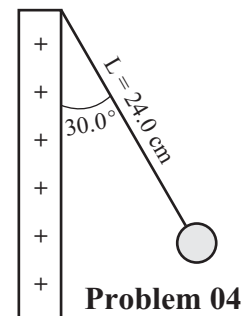

ANSWERS: 01. b.) 60,000 V/m c.) 0.0240 N d.) 0.400 μC 02. b.) 4500 V c.) 0.0277 N d.) 0.308 μC
 03. a.) 25,000 V b.) 4.00×10^{-15} N Up c.) 8.93×10^{-30} N d.) 4.39×10^{15} m/s² Up e.) 6.40×10^{-9} s
 03. f.) 17.0 cm g.) 2.40×10^{12} m/s² 04. a.) 1.81×10^{-3} N b.) 2.09×10^{-3} N c.) 1.05×10^{-3} N
 04. d.) 1.55×10^{-8} C

Electrostatics

Uniform Electric Fields-Potential Difference, Work, & Energy Homework #97

I

01. A small spherical 1.35-g conductor with a charge of $37.5 \mu\text{C}$ is placed in a uniform electric field with a strength of $65,000 \text{ V/m}$. The charge is mechanically moved 85.0 cm in a direction exactly opposite that of the electric field.
- What is the magnitude of the electrostatic force acting on this charge?
 - How much work was done in moving the charge?
 - What is the potential difference between the points where the charge started and ended?
 - If the charge were released and allowed to travel back to its original point, what would be its velocity there?

II

02. A 2.85-g charged particle ($q = -3500 \mu\text{C}$) is placed, initially at point A, between two oppositely-charged parallel plates that produce an electric field with a strength of $\vec{E} = 3750 \text{ V/m}$ between them which is directed toward the top of the page as shown in the diagram to the right.

- What is the electrostatic force (magnitude and direction) acting on this charge at point A?
- What is the minimum work done in moving the charge from point A to B?
- What is the potential difference between points A and B?
- If the charge is released from B and allowed to accelerate back to point A, what will be its velocity when it returns to point A?
- What is the potential difference between points B and C?
- What is the minimum work done in moving the charge from point B to C?
- What is the potential difference between points A and C?
- What is the minimum work done in moving the charge from point A to C?

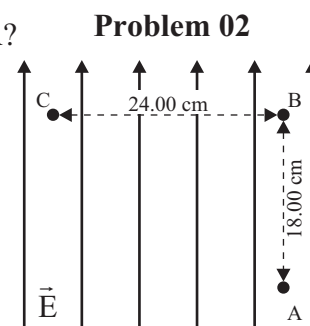

03. A proton is placed at point A between the two oppositely-charged parallel plates shown in the diagram to the right. The potential difference between the plates is 3000 V and the plates are 16.0 cm apart.

- What is the electrostatic force (magnitude) acting on this charge at point A?
- What is the potential difference between points A and B?
- If the charge is released from B and allowed to accelerate back to point A, what will be its velocity when it returns to point A?
- What is the minimum work done in moving the charge from point A to C?

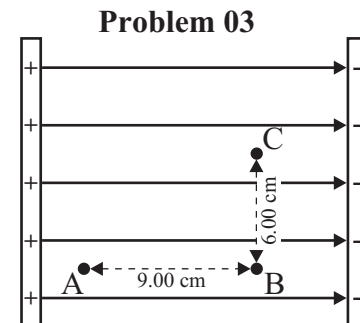

04. An AC power source heats the first negative plate in the diagram to the right allowing electrons to be "boiled off" (easily removed). The beam of electrons accelerates to the positive plate and continues at a constant speed (through a hole in the first plate) into the second electric field between the two horizontal plates.

- What is the velocity of the beam of electrons as it passes through the hole in the first positive plate?
- What is the magnitude of the electric field, \vec{E}_2 .
- What is the force on each electron in the second field?
- What is the acceleration of each electron in the second field?
- Sketch the path of the beam in \vec{E}_2 and calculate how long will it takes this beam to hit the positive plate.
- How far from the left edge of the positive plate will the beam of electrons exit the field (hit the positive plate)?

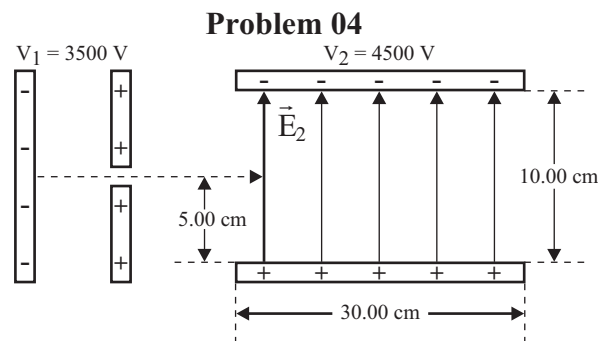

ANSWERS: 01. A.) 2.44 N b.) 2.07 J c.) 55,250 V d.) 55.4 m/s 02. a.) 13.1 N down b.) 2.36 J c.) 675 V
 d.) 40.7 m/s e.) 0 V f.) 0 J g.) 675 V h.) 2.36 J 03. a.) $3.00 \times 10^{-15} \text{ N}$ b.) 1688 V c.) $5.69 \times 10^5 \text{ m/s}$
 03. d.) $2.82 \times 10^{16} \text{ J}$ 04. a.) $3.51 \times 10^7 \text{ m/s}$ b.) 45,000 V/m c.) $7.20 \times 10^{-15} \text{ N}$ d.) $7.90 \times 10^{15} \text{ m/s}^2$
 04. e.) $3.56 \times 10^{-9} \text{ s}$ f.) 12.5 cm

Electrostatics

Electrostatic Potential-Point Sources

Homework #98

I

01. A small spherical $+8.00\text{-}\mu\text{C}$ charge is oriented as shown in the diagram to the right.

- a.) What is the magnitude and direction of the electric field at point A?
- b.) What would be the magnitude and direction of the electrostatic force acting on a proton if it were placed at A?
- c.) What would be the magnitude and direction of the electrostatic force acting on an electron if it were placed at A?
- d.) What is the electrostatic potential at point A?
- e.) What is the magnitude and direction of the electric field at point B?
- f.) What would be the magnitude and direction of the electrostatic force acting on a proton if it were placed at B?
- g.) What would be the magnitude and direction of the electrostatic force acting on an electron if it were placed at B?
- h.) What is the electrostatic potential at point B?
- i.) Which point is at a higher potential, point A or point B? Explain!
- j.) How much work is done by the field in moving a proton from point A to point B?
- k.) What minimum work would be required to move a proton from point A to point B?
- l.) What minimum work would be required to move an electron from point B to point A?
- m.) What is the electrostatic potential at a point that is an infinite distance away?
- n.) What is the potential difference between infinity and point B?
- o.) What minimum work would be required to move a proton from infinity to point B?
- p.) How much work is done by the field in moving a proton from point B to infinity?
- q.) What minimum work would be required to move an electron from infinity to point B?
- r.) What minimum work would be required to move a proton from point A to point C?
- s.) What minimum work would be required to move a proton from point A to point D?

Problem 01

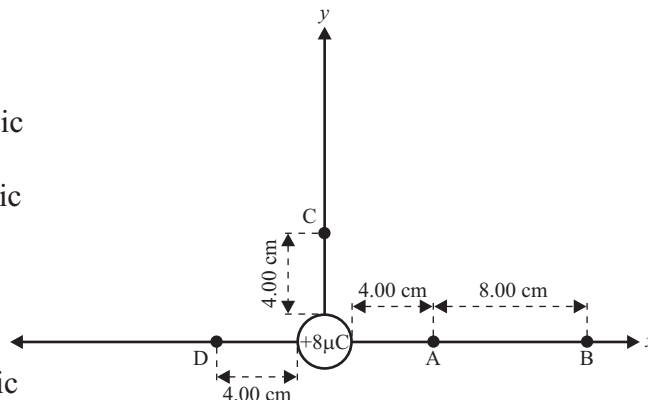

02. A small spherical $-8.00\text{-}\mu\text{C}$ charge is oriented as shown in the diagram to the right.

- a.) What is the magnitude and direction of the electric field at point A?
- b.) What is the potential difference between point A and point B?
- c.) What minimum work would be done in moving a proton from point A to point B?
- d.) What work is done by the field in moving a proton from infinity to point B?

Problem 02

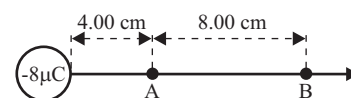

03. Three charges are arranged as shown in the diagram to the right.

- a.) What is the **NET** potential at point P?
- b.) How much work would be required to move an alpha particle (helium nucleus) from infinity to point P?

Problem 03

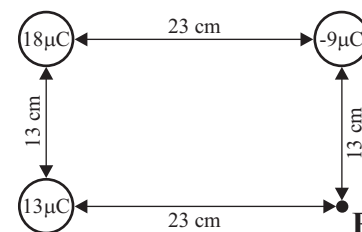

04. Find the electrostatic potential at 52.9 pm ($1\text{ pm} = 10^{-12}\text{ m}$) from the hydrogen nucleus. [This is the Bohr radius for an electron in the ground state]

ANSWERS: **01.** a.) $4.50 \times 10^7\text{ N/C}$ right b.) $7.20 \times 10^{-12}\text{ N}$ right c.) $7.20 \times 10^{-12}\text{ N}$ left d.) $1.80 \times 10^6\text{ V}$
01. e.) $5.00 \times 10^6\text{ N/C}$ right f.) $8.00 \times 10^{-13}\text{ N}$ right g.) $8.00 \times 10^{-13}\text{ N}$ left h.) $6.00 \times 10^5\text{ V}$ i.) point A
01. j.) $1.92 \times 10^{-13}\text{ J}$ k.) $1.92 \times 10^{-13}\text{ J}$ l.) $1.92 \times 10^{-13}\text{ J}$ m.) 0 V n.) $6.00 \times 10^5\text{ V}$ o.) $9.6 \times 10^{-14}\text{ J}$
01. p.) $9.60 \times 10^{-14}\text{ J}$ q.) $-9.60 \times 10^{-14}\text{ J}$ r.) 0 J s.) 0 J **02.** a.) $4.50 \times 10^7\text{ N/C}$ left b.) $1.20 \times 10^6\text{ V}$
02. c.) $1.92 \times 10^{-13}\text{ J}$ d.) $9.60 \times 10^{-14}\text{ J}$ **03.** a.) $4.99 \times 10^5\text{ V}$ b.) $-1.60 \times 10^{-13}\text{ J}$ **04.** 27.2 J

Electrostatics

Capacitors

Homework #99

I

01. The two plates of a capacitor hold equal but opposite charges of $2500 \mu\text{C}$ when the potential difference is 900 V . What is the capacitance of the capacitor?
02. How much charge flows to a $6.25\text{-}\mu\text{F}$ capacitor when it is connected to a 20.0-V battery?
03. A $16,500 \text{ pF}$ capacitor holds a charge of $0.280 \mu\text{C}$. What is the potential difference between the two plates of the capacitor?
04. A capacitor consists of two square parallel plates 14.0 cm on a side separated by 3.45 mm of hard rubber. What is the capacitance of this capacitor?
05. What is the area of each plate of a $9.62 \times 10^{-10} \text{ F}$ capacitor if the plates have 2.85 mm of air between them?
06. Each of the two plates of a 90.0-pF capacitor (air gap) has an area of 0.0475 m^2 . How far apart are the two plates?
07. How much energy is stored on 2750-pF capacitor when 250 V are applied to it?

II

08. The charge on a capacitor increases by $22.0 \mu\text{C}$ when the voltage across it increases from 18 V to 32 V . What is the capacitance of this capacitor?
09. Two 645-cm^2 parallel plates separated by 2.25 cm are to have an electric field $34.0 \times 10^6 \text{ V/m}$.
 - a.) If the plates are separated by air, what is the charge on each plate?
 - b.) If the plates are separated by mica, what is the charge on each plate?
 - c.) If the plates are separated by paraffin, what is the charge on each plate?
10. What is the strength of the electric field between the plates of a $25.0\text{-}\mu\text{F}$ capacitor with an air gap of 2.70 mm if each plate has a charge of $675 \mu\text{C}$?
11. Two square plates, 25.0 cm on a side, are separated 4.42 mm apart. Each plate holds an equal but opposite charge of $725 \mu\text{C}$. How much energy is stored if the gap between the plates is filled with _____?
 - a.) air
 - b.) mica

III

12. A $7.25\text{-}\mu\text{F}$ capacitor is charged fully by an 18.00-V battery and then disconnected from the battery. The charged capacitor is subsequently connected to a second capacitor, C_2 , that is initially uncharged. When equilibrium is reached (charges no longer flow), the voltage on the first capacitor drops to 8.00 V . What is the capacitance of C_2 ?
13. A $12.4\text{-}\mu\text{F}$ capacitor is charged to 1600 V while a $19.8\text{-}\mu\text{F}$ capacitor is charged to 950 V . The positive plates of the two capacitors are connected as are their negative plates. Eventually equilibrium is established.
 - a.) What is the potential difference across each?
 - b.) What is the charge on each?

ANSWERS: **01.** $2.780 \mu\text{F}$ **02.** $125 \mu\text{C}$ **03.** 17.0 V **04.** 141 pF **05.** 0.310 m^2 **06.** 4.67 mm
07. $8.59 \times 10^{-5} \text{ J}$ **08.** $1.57 \mu\text{F}$ **09.** a.) $19.4 \mu\text{C}$ b.) $136 \mu\text{C}$ c.) $42.7 \mu\text{C}$ **10.** $10,000 \text{ V}$
11. a.) 2100 J b.) 300 J **12.** $9.00 \mu\text{F}$ **13.** a.) 1200 V b.) $Q_1 = 14.9 \text{ mC}$, $Q_2 = 23.8 \text{ mC}$

Electrostatics

Electrostatic Review

Homework # 100

01. Consider the set of charged particles distributed as shown to the right where:

$$A = 14.0 \mu\text{C} \quad B = -5.00 \mu\text{C} \quad C = 7.00 \mu\text{C}$$

$$d_1 = 20.0 \text{ cm} \quad d_2 = 15.0 \text{ cm}$$

- a.) What will be the magnitude of the electrostatic force between the B and C?
- b.) What will the direction and magnitude of the electric field at point P?
- c.) What will be the electrostatic potential at point P?
- d.) What will the magnitude of the electrostatic force acting on a $3.00 \mu\text{C}$ charge placed at point P?

Problem 01

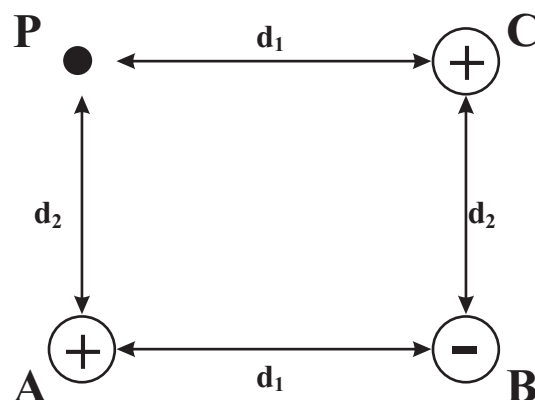

Problem 02

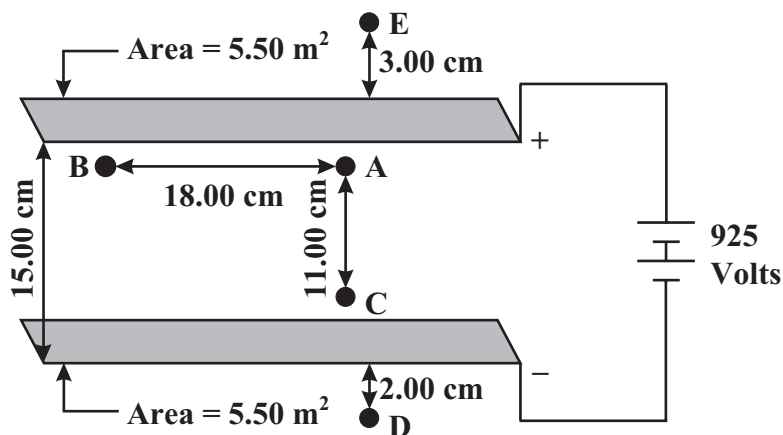

02. A capacitor consists of two horizontal parallel plates separated by air. Each of the plates has an area of 5.50 m^2 and the plates are separated by a distance of 15.0 centimeters.

- a.) What is the capacitance of this parallel plate capacitor?
- b.) What would be the capacitance of this capacitor if the air between the plates is replaced by polyethylene which has a dielectric constant of 2.3 ?

For Parts c.) through i.), assume polyethylene is between the plates.

- c.) How much charge will be stored on each plate of this capacitor under these conditions?
- d.) What will be the direction and the magnitude of the electric field at point C?
- e.) What will be the magnitude of the electric field at point D?
- f.) How much work will be done in moving a $1.20 \mu\text{C}$ charge between point A and point B?
- g.) What will be the potential difference between points B and C?
- h.) What will be the potential difference between points A and C?
- i.) What will be the potential difference between points D and E?

ANSWERS: **01.** a.) 14.0 N b.) $5.26 \times 10^6 \text{ N/C}$ @ 79.0° above the negative x-axis c.) $9.75 \times 10^5 \text{ V}$
01. d.) 15.8 N @ 79.0° above the negative x-axis **02.** a.) $3.25 \times 10^{-10} \text{ F}$ b.) $7.46 \times 10^{-10} \text{ F}$
02. c.) $6.91 \times 10^{-7} \text{ C}$ d.) 6167 N/C e.) 0 N/C f.) 0 J g.) 678 V h.) 678 V i.) 0 V

Electrostatics

Electrostatic Review

Homework # 101

03. Two vertical plates are arranged so as to accelerate a negatively charged particle, q , which has a charge of $0.0050 \mu\text{C}$ and a mass of 1.10×10^{-9} grams, as shown to the right. The potential difference between the plates is 4800 V and the plates are spaced 3.80 cm apart. A second pair of plates are arranged horizontally as shown. The two horizontal plates are spaced 5.00 cm apart and are 15.5 cm long and are likewise charged

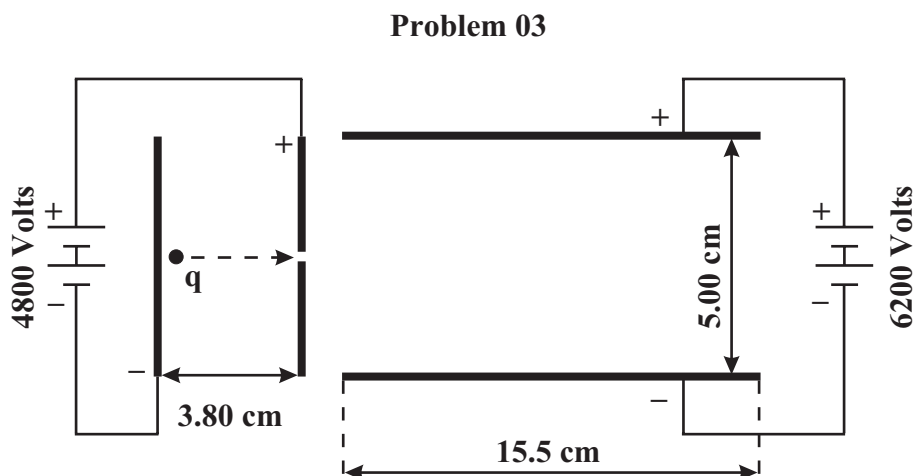

to a potential of 6200 V . The charge q begins at the negative plate and then accelerates to the right until it passes through a hole in the center of the positive plate. This charge then passes into the area between the two horizontal plates exactly midway between the two plates.

- What will be the kinetic energy of the charge q just as it passes through the hole in the positive plate?
- What will be the velocity of the charge as it passes through the hole in the positive plate?
- What will be the direction and magnitude of the force exerted on this charged particle as it passes into the space between the two horizontal plates?
- What will be the velocity of this particle as it exits the area between the two horizontal plates?
- Exactly where will the charged particle exit the electric field between the two horizontal plates?

04. Consider a point charge of $q_1 = 8.80 \mu\text{C}$ as shown in the diagram to the right. Points A, B and C represent three points near q_1 . An alpha particle [$q_\alpha = +3.20 \times 10^{-19} \text{ C}$ and $m_\alpha = 6.69 \times 10^{-27} \text{ kg}$] is located infinitely far away to the right off the edge of the paper.

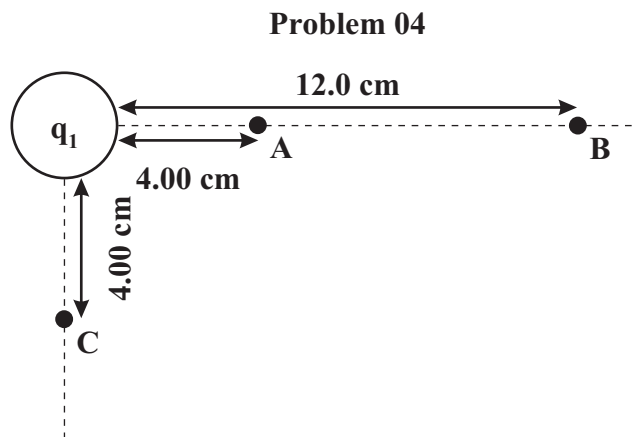

- What will be the electrostatic potential at point A?
- How much work would be required to bring this α particle from infinity to point A?
- What will be the potential difference between points A and B?
- How much additional work would be required to move this α particle from point A to point B?
- What is the potential difference between point A and point C?
- How much work would be required to move this α particle from point A to point C?
- How much work would be required to move this α particle from point B to point C?
- Suppose that this α particle, while at point A, is released and is allowed to accelerate back to point B. What will be the velocity of this α particle just as it reaches point B?

ANSWERS: 03. a.) $2.40 \times 10^{-5} \text{ J}$ b.) $6.61 \times 10^3 \text{ m/s}$ c.) Up; $6.20 \times 10^{-4} \text{ N}$
 d.) $8.48 \times 10^5 \text{ m/s}$ @ 38.8° above the horizontal e.) 6.23 cm 04. a.) $1.98 \times 10^6 \text{ V}$ b.) $6.34 \times 10^{-13} \text{ J}$
 c.) $1.32 \times 10^6 \text{ V}$ d.) $4.22 \times 10^{-13} \text{ J}$ e.) 0 J f.) 0 V g.) $4.2 \times 10^{-13} \text{ J}$ h.) $1.12 \times 10^7 \text{ m/s}$

Engineering Electrostatics: Continuous Charge Distributions

Electric Field Calculations Using Coulomb's Law

Homework # 102

II

01. The uniform finite line charge shown in the diagram to the right has a charge of Q and a length of L .

- Determine the linear charge density, λ , for this line charge.
- What is the relationship between a small segment of this line charge, dx , the small amount of charge in this segment, dq , and the linear charge density, λ .
- Determine the electric field at point P in terms of Q , L , x_0 , and Coulomb's constant, k .
- Determine the electric field at point P in terms of Q , L , x_0 , and Coulomb's constant, k , if $x_0 \gg L$.
- Determine the electric field at point P with the following data: $Q = +25.0 \mu\text{C}$, $L = 10.0 \text{ cm}$, and $x_0 = 11.4 \text{ cm}$.
- Determine the electric field at point P with the following data: $Q = +25.0 \mu\text{C}$, $L = 10.0 \text{ cm}$, and $x_0 = 4.65 \text{ m}$.

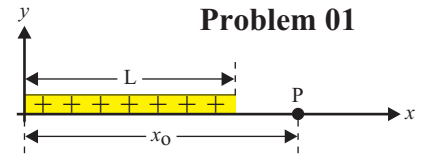

Problem 01

02. The uniform finite line charge shown in the diagram to the right has a charge of Q and a length of L . The y -axis is a perpendicular bisector of this line charge.

- Determine the linear charge density, λ , for this line charge.
- What is the relationship between a small segment of this line charge, dx , the small amount of charge in this segment, dq , and the linear charge density, λ .
- Determine the **NET** x -component of the electric field at point P.
- Sketch the vector $d\vec{E}$ and show its x and y components at point P.
- Determine $\frac{dE_y}{dx}$ at the point P in terms of dx , r , λ , θ , and Coulomb's constant, k .
- Determine x in terms of y and θ .
- Determine $\frac{dx}{d\theta}$ at the point P in terms of r and y .
- Determine E_{NET} at point P in terms of L , y , λ , and Coulomb's constant, k .
- Determine E_{NET} at point P in terms of Q , y , and Coulomb's constant, k , if $y \gg L$.
- Determine E_{NET} at point P with the following data: $Q = +25.0 \mu\text{C}$, $L = 10.0 \text{ cm}$, and $y = 6.00 \text{ cm}$.
- Determine E_{NET} at point P with the following data: $Q = +25.0 \mu\text{C}$, $L = 10.0 \text{ cm}$, and $y = 4.65 \text{ m}$.

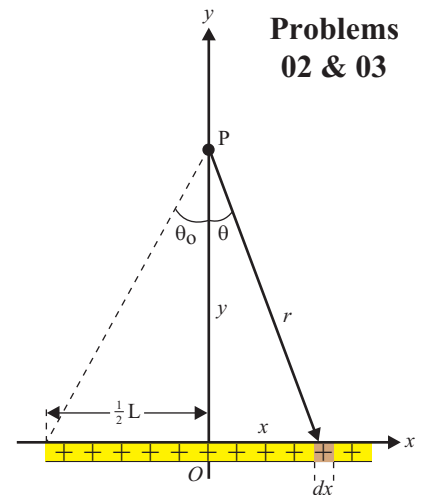

Problems 02 & 03

03. Assume the uniform line charge shown in the diagram above and to the right is very long (infinite line charge) compared to y . Determine the electric field at point P in terms of y , λ , and Coulomb's constant, k , if $L \gg y$.

ANSWERS: **01.** a.) $\lambda = \frac{Q}{L}$ b.) $dq = \lambda \cdot dx$ c.) $E = k \frac{Q}{x_0(x_0 - L)}$ d.) $E = k \frac{Q}{x_0^2}$ e.) $1.48 \times 10^8 \text{ N/C}$

01. e.) $1.04 \times 10^4 \text{ N/C}$ **02.** a.) $\lambda = \frac{Q}{L}$ b.) $dq = \lambda \cdot dx$ c.) 0 e.) $\frac{dE_y}{dx} = k \frac{\lambda dx}{r^2} \cos\theta$ ($dE_y = k \frac{\lambda dx}{r^2} \cos\theta$)

02. f.) $x = y \cdot \tan\theta$ g.) $\frac{dx}{d\theta} = \frac{r^2}{y} \left(dx = \frac{r^2}{y} d\theta \right)$ h.) $E_{\text{NET}} = \frac{k\lambda L}{y \sqrt{\left(\frac{1}{2}L\right)^2 + y^2}}$ i.) $E_{\text{NET}} = k \frac{Q}{y^2}$ j.) $4.80 \times 10^7 \text{ N/C}$

02. k.) $1.04 \times 10^4 \text{ N/C}$ **03.** $E_{\text{NET}} = \frac{2k\lambda}{y}$

Engineering Electrostatics: Continuous Charge Distributions

Electric Field Calculations Using Coulomb's Law

Homework # 103

II

04. A thin ringed object with a uniform charge of Q (+) and a radius of a is shown in the diagram to the right. Notice x , a , θ , and r are all constants. Point P is on the axis of the ring.

- Sketch the vector $d\vec{E}$ and show its x and y components at point P.
- Determine the **NET** y -component of the electric field at point P.
- Describe dE_x in its simplest form in terms of x , a , dq , and k .
- Determine E_{NET} at point P in terms of Q , x , a , and k .
- Determine E_{NET} at point P in terms of Q , x , a , and k , if $x \gg a$.
- Determine E_{NET} at point P with the following data: $Q = +25.0 \mu\text{C}$, $a = 10.0 \text{ cm}$, and $x = 6.00 \text{ cm}$.
- Determine E_{NET} at point P with the following data: $Q = +25.0 \mu\text{C}$, $a = 10.0 \text{ cm}$, and $x = 4.65 \text{ m}$.

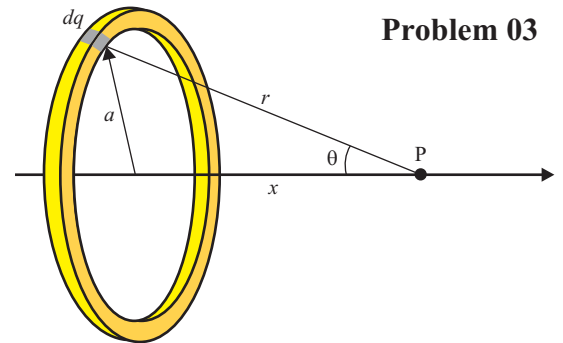

Problem 03

05. A solid disk with a uniform charge of Q (+) and a radius of R is shown in the diagram to the right. Notice x and R are both constants. Point P is on the axis of the disk.

- Determine the area charge density, σ , for this disk of charge.
- Sketch the vector $d\vec{E}$ and show its x and y components at point P.
- Determine the **NET** y -component of the electric field at point P.
- Describe dE_x in its simplest form in terms of x , a , dq , and k .
- Determine E_{NET} at point P in terms of Q , x , a , and k .
- Determine E_{NET} at point P in terms of Q , x , a , and k , if $x \gg R$.
- Determine E_{NET} at point P in terms of Q , x , a , and k , if $R \gg x$ (as if the disk were an infinite plane of charge).
- Determine E_{NET} at point P with the following data: $Q = +25.0 \mu\text{C}$, $R = 10.0 \text{ cm}$, and $x = 6.00 \text{ cm}$.
- Determine E_{NET} at point P with the following data: $Q = +25.0 \mu\text{C}$, $R = 10.0 \text{ cm}$, and $x = 4.65 \text{ m}$.
- Determine E_{NET} at point P with the following data: $Q = +25.0 \mu\text{C}$, $R = 4.65 \text{ m}$, and $x = 6.00 \text{ cm}$.

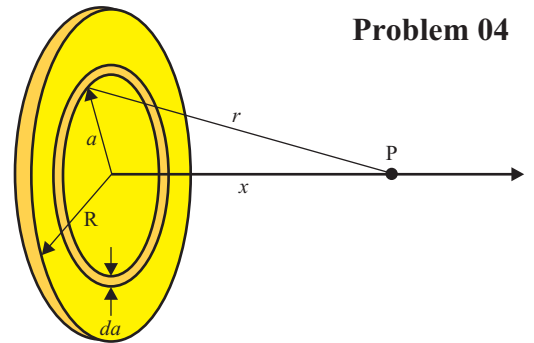

Problem 04

ANSWERS: 04. b.) 0 c.) $dE_x = k \frac{dq}{(x^2 + a^2)^{3/2}} x$ d.) $E_{\text{NET}} = \frac{kQx}{(x^2 + a^2)^{3/2}}$ e.) $E_{\text{NET}} = k \frac{Q}{x^2}$ e.) $8.51 \times 10^6 \text{ N/C}$

04. f.) $1.04 \times 10^4 \text{ N/C}$ 05. a.) $\sigma = \frac{Q}{A} = \frac{Q}{\pi R^2}$ c.) 0 d.) $dE_x = k \frac{2\pi a da}{(x^2 + a^2)^{3/2}} x$ e.) $E_{\text{NET}} = 2\pi k \sigma \left(1 - \frac{x}{\sqrt{x^2 + R^2}} \right)$

05. f.) $E_{\text{NET}} = k \frac{Q}{x^2}$ g.) $E_{\text{NET}} = 2\pi k \sigma$ h.) $2.18 \times 10^7 \text{ N/C}$ i.) $1.04 \times 10^4 \text{ N/C}$ j.) $2.08 \times 10^4 \text{ N/C}$

Engineering Electrostatics: Continuous Charge Distributions

Electric Field Calculations Using Gauss's Law

Homework # 104

II

01. A point charge with a charge of Q (+) is shown in the diagram to the right.
- Sketch the electric field lines on the diagram to the right.
 - What should be the shape of a Gaussian surface such that the strength of the electric field will be a constant everywhere on this surface and the direction of the electric field will be perpendicular to the surface at all points on the surface?
 - Use Gauss's law to derive a mathematical expression to predict the electric field strength as a function of its distance, r , from the point source.
 - On the graph to the right and below, graph the expression derived in c.) above.
02. If the point charge in the diagram above and to the right has a charge of $+25.0 \mu\text{C}$, find the field strength at a distance of 6.00 cm from the point source.

Problems 01 & 02

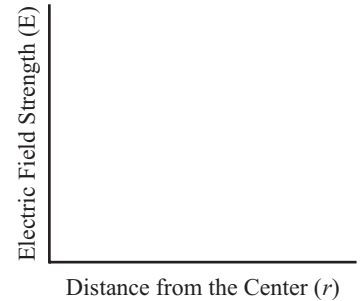

03. A hollow spherical shell (negligible thickness) with a uniformly distributed charge is shown in the diagram to the right. The shell has a net charge of Q (+) and a radius of R .
- Sketch the electric field lines on the diagram to the right.
 - What is the surface charge density, σ , of the spherical shell?
 - What should be the shape of a Gaussian surface such that the strength of the electric field will be a constant everywhere on this surface and the direction of the electric field will be perpendicular to the surface at all points on the surface?
 - Use Gauss's law predict the electric field anywhere inside the shell.
 - Use Gauss's law to derive a mathematical expression to predict the electric field strength as a function of its distance outside the spherical shell.
 - On the graph to the right and below, graph the expression derived in d.) and e.) above.
 - What is the difference in electric field strength between a point just inside the sphere and one just outside the spherical shell (the amount of discontinuity).

Problems 03 & 04

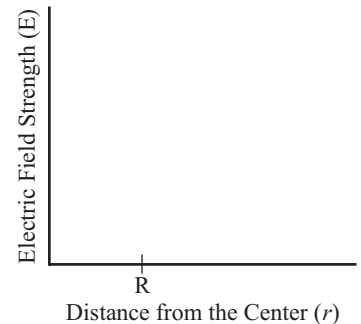
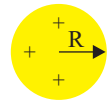

04. Assume the shell in the diagram above and to the right has a charge of $+25.0 \mu\text{C}$ and a radius of 10.0 cm.
- What is the surface charge density, σ , of the spherical shell?
 - Find the field strength at a distance of 6.00 cm from the center of the shell.
 - Find the field strength at a distance of 16.00 cm from the center of the shell.
 - Find the field strength at a distance of 6.00 m from the center of the shell.

ANSWERS: **01.** b.) sphere c.) $E_{\text{NET}} = \frac{1}{4\pi\epsilon_0} \frac{Q}{r^2}$ **02.** $6.25 \times 10^7 \text{ N/C}$

03. b.) $\sigma = \frac{Q}{A} = \frac{Q}{4\pi R^2}$ c.) sphere d.) 0 e.) $E_{\text{NET}} = \frac{1}{4\pi\epsilon_0} \frac{Q}{r^2} = \frac{\sigma}{\epsilon_0}$ g.) $\frac{\sigma}{\epsilon_0}$

04. a.) $199 \mu\text{C}/\text{m}^2$ b.) 0 c.) $8.79 \times 10^9 \text{ N/C}$ d.) 6250 N/C

Engineering Electrostatics: Continuous Charge Distributions

Electric Field Calculations Using Gauss's Law

Homework # 105

II

05. A solid spherical insulating material with a uniformly distributed charge is shown in the diagram to the right. The sphere has a net charge of Q (+) and a radius of R .
- Sketch the electric field lines on the diagram to the right.
 - What is the charge density, ρ , of the sphere?
 - What should be the shape of a Gaussian surface such that the strength of the electric field will be a constant everywhere on this surface and the direction of the electric field will be perpendicular to the surface at all points on the surface?
 - Use Gauss's law predict the electric field anywhere inside the sphere.
 - Use Gauss's law to derive a mathematical expression to predict the electric field strength as a function of its distance outside the sphere.
 - On the graph to the right and below, graph the expression derived in c.) and d.) above.
 - What is the difference in electric field strength between a point just inside the sphere and one just outside the sphere (the amount of discontinuity).

Problems 05 & 06

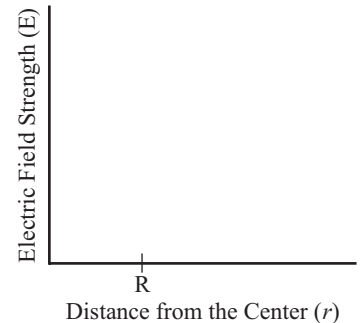
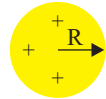

06. Assume the solid sphere in the diagram above and to the right has a charge of $+25.0 \mu\text{C}$ and a radius of 10.0 cm .
- What is the charge density, ρ , of the sphere?
 - Find the field strength at a distance of 6.00 cm from the center of the sphere.
 - Find the field strength at a distance of 16.00 cm from the center of the sphere.
 - Find the field strength at a distance of 6.00 m from the center of the sphere.

Problems 07 & 08

07. An infinite line charge with a uniformly distributed charge shown in the diagram to the right has a linear charge density of λ .
- Sketch the electric field lines on the diagram to the right.
 - What should be the shape of a Gaussian surface such that the strength of the electric field will be a constant everywhere on this surface and the direction of the electric field will be perpendicular to the surface at all points on the surface?
 - Use Gauss's law to derive a mathematical expression to predict the electric field strength as a function of its distance from the line charge.
 - On the graph to the right and below, graph the expression derived in c.) above.
08. Assume the infinite line charge in the diagram above and to the right has a line charge density, λ , of $+250 \mu\text{C}/\text{m}$.
- Find the field strength at a distance of 6.00 cm from the line charge.
 - Find the field strength at a distance of 16.00 cm from the line charge.
 - Find the field strength at a distance of 6.00 m from the line charge.



ANSWERS: **05.** b.) $\rho = \frac{Q}{V} = \frac{Q}{\frac{4}{3}\pi R^3}$ c.) sphere d.) $E_{\text{NET}} = \frac{1}{4\pi\epsilon_0} \frac{Q}{R^3} r = k \frac{Q}{R^3} r$ e.) $E_{\text{NET}} = \frac{1}{4\pi\epsilon_0} \frac{Q}{r^2} = k \frac{Q}{r^2}$
05. g.) no discontinuity (continuous) **06.** a.) $5.97 \text{ mC}/\text{m}^3$ b.) $1.37 \times 10^7 \text{ N}/\text{C}$ c.) $8.79 \times 10^6 \text{ N}/\text{C}$ d.) $6250 \text{ N}/\text{C}$
07. b.) cylinder c.) $E_{\text{NET}} = \frac{1}{2\pi\epsilon_0} \frac{\lambda}{r} = \frac{2k\lambda}{r}$ **08.** a.) $7.50 \times 10^7 \text{ N}/\text{C}$ b.) $2.81 \times 10^7 \text{ N}/\text{C}$ c.) $7.50 \times 10^5 \text{ N}/\text{C}$

Engineering Electrostatics: Continuous Charge Distributions

Electric Field Calculations Using Gauss's Law

Homework # 106

II

09. A hollow cylindrical shell (negligible thickness) with a uniformly distributed charge is shown in the diagram to the right. The shell has a net charge of Q (+), a radius of R , and a length of L .

- Sketch the electric field lines on the diagram to the right.
- What is the surface charge density, σ , of the cylindrical shell?
- What should be the shape of a Gaussian surface such that the strength of the electric field will be a constant everywhere on this surface and the direction of the electric field will be perpendicular to the surface at all points on the surface?
- Use Gauss's law predict the electric field anywhere inside the shell.
- Use Gauss's law to derive a mathematical expression to predict the electric field strength as a function of its distance outside the cylindrical shell.
- On the graph to the right, graph the expression derived in d.) and e.) above.
- What is the difference in electric field strength between a point just inside the sphere and one just outside the spherical shell (the amount of discontinuity).

Problems 09 & 10

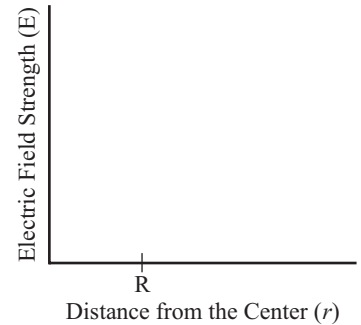
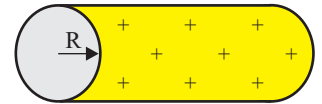

10. Assume the shell in the diagram above and to the right has a charge of $+25.0 \mu\text{C}$, a radius of 10.0 cm , and a length of 20.0 cm .

- What is the surface charge density, σ , of the spherical shell?
- Find the field strength at a distance of 6.00 cm from the center of the shell.
- Find the field strength at a distance of 16.00 cm from the center of the shell.
- Find the field strength at a distance of 6.00 m from the center of the shell.

11. An infinitely long solid cylindrical insulating material with a uniformly distributed charge is shown in the diagram to the right. The cylinder has a net charge of Q (+) and a radius of R .

- What is the charge density, ρ , of the cylinder?
- What should be the shape of a Gaussian surface such that the strength of the electric field will be a constant everywhere on this surface and the direction of the electric field will be perpendicular to the surface at all points on the surface?
- Use Gauss's law predict the electric field anywhere inside the cylinder.
- Use Gauss's law to derive a mathematical expression to predict the electric field strength as a function of its distance outside the cylinder.
- On the graph to the right, graph the expression derived in c.) and d.) above.
- What is the difference in electric field strength between a point just inside the cylinder and one just outside the sphere (the amount of discontinuity).

Problem 11

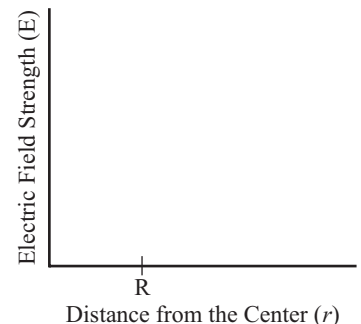
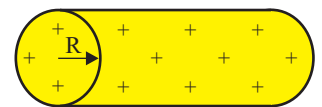

12. Consider an infinite plane of charge with a surface charge density of σ .

- What is the **NET** electric field near the plane.
- What is the amount of discontinuity of the electric fields on the two sides of the plane?

ANSWERS: 09. b.) $\sigma = \frac{Q}{A} = \frac{Q}{2\pi RL}$ c.) cylinder d.) 0 e.) $E_{\text{NET}} = \frac{1}{2\pi\epsilon_0} \frac{\lambda}{r} = \frac{2k\lambda}{r}$ g.) $\frac{\sigma}{\epsilon_0}$ 10. a.) $199 \mu\text{C}/\text{m}^2$
 10. b.) 0 c.) $2.24 \times 10^7 \text{ N/C}$ d.) $5.97 \times 10^5 \text{ N/C}$ 11. a.) $\rho = \frac{Q}{V} = \frac{Q}{\pi R^2 L}$ b.) cylinder
 11. c.) $E_{\text{NET}} = \frac{\rho}{2\epsilon_0} r = \frac{\lambda}{2\pi\epsilon_0 R^2} r$ d.) $E_{\text{NET}} = \frac{1}{2\pi\epsilon_0} \frac{\lambda}{r}$ f.) no discontinuity (continuous) 12. a.) $E_{\text{NET}} = \frac{\sigma}{2\epsilon_0}$ b.) $\frac{\sigma}{\epsilon_0}$

Engineering Electrostatics: Continuous Charge Distributions

Potential Calculations of Continuous Charge Distributions Homework # 107

II

01. A thin ringed object with a uniform charge of Q (+) and a radius of a is shown in the diagram to the right. Notice x , a , and r are all constants. Point P is on the axis of the ring.

- What is the potential at point P?
- How much work would be required to move a positive charge of q from point P to a very large distance away (infinity)?

For parts c.) and d.) assume $Q = +25.0 \mu\text{C}$, $a = 10.0 \text{ cm}$, and $x = 6.00 \text{ cm}$.

- Determine the potential at point P.
- How much work would be required to move a proton from point P to a very large distance away (infinity)?

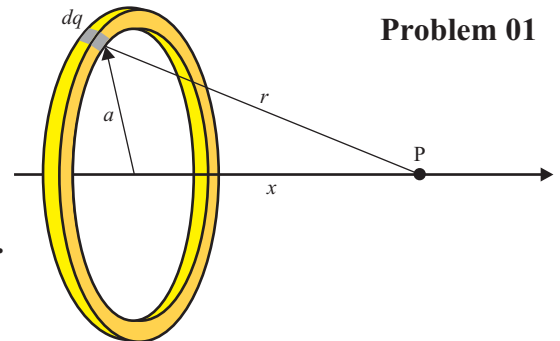

Problem 01

02. A solid disk with a uniform charge of Q (+) and a radius of R is shown in the diagram to the right. Notice x and R are both constants. Point P is on the axis of the disk.

- What is the potential at point P?
- How much work would be required to move a positive charge of q from point P to a very large distance away (infinity)?

For parts c.) and d.) assume $Q = +25.0 \mu\text{C}$, $a = 10.0 \text{ cm}$, and $x = 6.00 \text{ cm}$.

- Determine the potential at point P.
- How much work would be required to move a proton from point P to a very large distance away (infinity)?

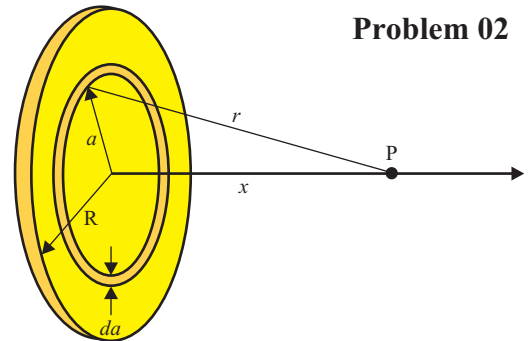

Problem 02

03. Consider an infinite vertical plane of charge oriented along the y -axis with a surface charge density of σ .

- Write a mathematical expression that describes the potential as a function of distance from the plane along the x -axis (both positive and negative x -axis). Assume the potential at the vertical plane of charge ($x = 0$) is 100 V.
- Sketch a graph of the expression determined in a.) above. Is the graph continuous?

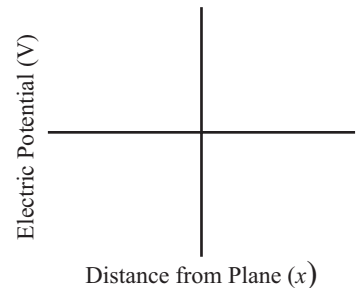

04. A hollow spherical shell (negligible thickness) with a uniformly distributed charge has a net charge of Q (+) and a radius of R .

- Write a mathematical expression that describes the potential as a function of distance from the center of the shell, r (both inside and outside the shell).
- Sketch a graph of the expression determined in a.) above. Is the graph continuous?

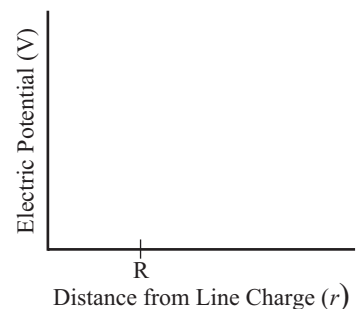

05. Consider an infinite line charge with a uniformly distributed charge that has a linear charge density of λ . Write a mathematical expression that describes the potential as a function of distance from the line charge, r . Assume $V = 100 \text{ V}$ at $r = 0$.

ANSWERS: 01. a.) $V = k \frac{Q}{\sqrt{x^2 + a^2}}$ b.) $W_{P\infty} = k \frac{Q \cdot q}{\sqrt{x^2 + a^2}}$ c.) $1.93 \times 10^6 \text{ V}$ d.) $3.09 \times 10^{-13} \text{ J}$
 02. a.) $V = 2\pi k \sigma (\sqrt{x^2 + a^2} - x)$ b.) $W_{P\infty} = 2\pi k \sigma (\sqrt{x^2 + a^2} - x) q$ c.) $2.55 \times 10^6 \text{ V}$ d.) $4.08 \times 10^{-13} \text{ J}$
 03. a.) $V(x) = 100 - \frac{\sigma}{2\epsilon_0} x$ b.) yes 04. a.) $V(r) = k \frac{Q}{R} (r \leq R)$, $V(r) = k \frac{Q}{r} (r > R)$ b.) yes
 05. $V(r) = 100 - 2k\lambda \ln(r)$

Engineering Electrostatics: Continuous Charge Distributions

Electric Field & Potential of Multiple Charged Objects Homework # 108

II

01. The diagram to the right shows the cross section of two concentric, conducting spherical shells (each with negligible thickness). The smaller, inner shell has a radius, R_1 , of 6.00 cm and a charge, Q_1 , of $+18.0 \mu\text{C}$. The larger, outer shell has a radius, R_2 , of 9.00 cm and a charge, Q_2 , of $-11.0 \mu\text{C}$.

Problem 01

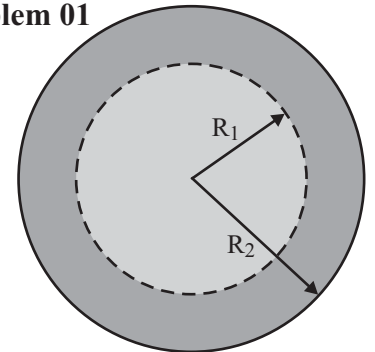

- What is the **NET** electrostatic potential of the outer shell?
- Determine the constant of integration when calculating the **NET** electrostatic potential between the two shells.
- What is the **NET** electrostatic potential of the inner shell?
- What is the potential difference between the inner shell and the outer shell?
- What is the **NET** electrostatic potential at the center of the two shells?
- How much work would be required to move an electron from the inner shell to the outer shell?
- How much work would be required to move a proton from infinity to the outer shell?
- Write an equation describing the **NET** electric field inside the inner shell (where $r \leq R_1$).
- Write an equation describing the **NET** electric field as a function of distance from the center, r , for $R_1 < r \leq R_2$.
- Write an equation describing the **NET** electric field as a function of distance from the center, r , where $r > R_2$.
- What is the **NET** electric field 4.00 cm outside the outer shell?

02. The diagram to the right shows two concentric, conducting cylindrical shells (each with negligible thickness). The radii ($R_1 = 6.00 \text{ cm}$ and $R_2 = 9.00 \text{ cm}$) and charges ($Q_1 = +18.0 \mu\text{C}$ and $Q_2 = -11.0 \mu\text{C}$) of these cylindrical shells are identical to those of the spherical shells in problem 01 above. Both shells have an equal length of 60.0 cm. Assume the **NET** electrostatic potential is zero at a radial distance of 100.0 m from the center of the two shells.

Problem 02

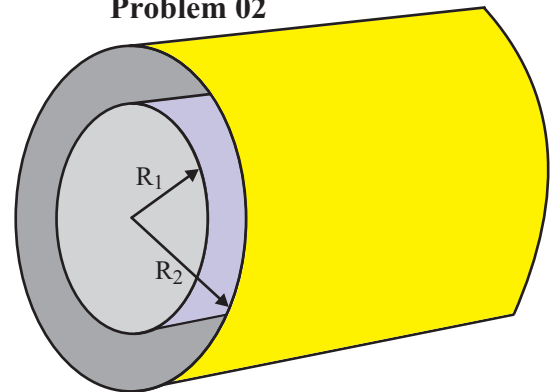

- Determine the constant of integration when calculating the **NET** electrostatic potential outside the two shells.
- What is the **NET** electrostatic potential of the outer shell?
- Determine the constant of integration when calculating the **NET** electrostatic potential between the two shells.
- What is the **NET** electrostatic potential of the inner shell?
- What is the potential difference between the inner shell and the outer shell?
- What is the **NET** electrostatic potential at the center of the two shells?
- How much work would be required to move an electron from the inner shell to the outer shell?
- How much work would be required to move a proton from a position 100.0 m from the center to the outer shell?
- Write an equation describing the **NET** electric field inside the inner shell (where $r \leq R_1$).
- Write an equation describing the **NET** electric field as a function of distance from the center, r , for $R_1 < r \leq R_2$.
- Write an equation describing the **NET** electric field as a function of distance from the center, r , where $r > R_2$.
- What is the **NET** electric field 4.00 cm outside the outer shell?

ANSWERS: 01. a.) $7.00 \times 10^5 \text{ V}$ b.) $-1.10 \times 10^6 \text{ V}$ c.) $1.60 \times 10^6 \text{ V}$ d.) $9.00 \times 10^5 \text{ V}$ e.) $1.60 \times 10^6 \text{ V}$
 01. f.) $1.44 \times 10^{-13} \text{ J}$ g.) $1.12 \times 10^{-13} \text{ J}$ h.) $E = 0$ i.) $E = \frac{1}{4\pi\epsilon_0} \frac{Q_1}{r^2} = \frac{1.62 \times 10^5}{r^2}$ j.) $E = \frac{1}{4\pi\epsilon_0} \frac{(Q_1 + Q_2)}{r^2} = \frac{6.30 \times 10^4}{r^2}$
 01. k.) $3.73 \times 10^6 \text{ N/C}$ 02. a.) $-9.67 \times 10^5 \text{ V}$ b.) $-1.47 \times 10^6 \text{ V}$ c.) $-1.72 \times 10^5 \text{ V}$ d.) $-1.69 \times 10^6 \text{ V}$
 02. e.) $2.19 \times 10^5 \text{ V}$ f.) $-1.69 \times 10^6 \text{ V}$ g.) $3.50 \times 10^{-14} \text{ J}$ h.) $-2.36 \times 10^{-13} \text{ J}$ i.) $E = 0$
 02. j.) $E = \frac{1}{2\pi\epsilon_0} \frac{\lambda_1}{r} = 2k \frac{Q_1/L}{r} = \frac{5.40 \times 10^5}{r}$ k.) $E = \frac{1}{2\pi\epsilon_0} \frac{\lambda_1}{r} = 2k \frac{(Q_1 + Q_2)/L}{r} = \frac{2.10 \times 10^5}{r}$ l.) $1.62 \times 10^6 \text{ N/C}$

Engineering Electrostatics: Continuous Charge Distributions

Electric Field & Potential of Multiple Charged Objects Homework # 109

II

03. The diagram to the right shows the cross section of a conducting spherical shell with a thickness of 2.00 cm. The inner surface of the shell has a radius, R_1 , of 8.00 cm, while the outer surface has a radius, R_2 , of 10.00 cm. The charge on the shell is $Q_2 = +14.00 \mu\text{C}$. The shell encloses a point charge located at its center with a charge of $Q_1 = -5.00 \mu\text{C}$.

Problem 03

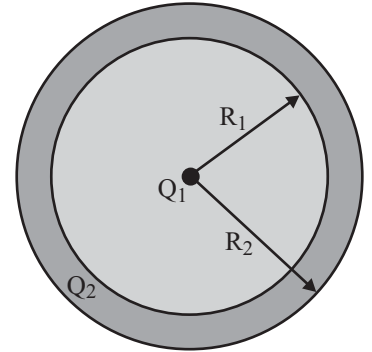

- a.) What is the **NET** electrostatic potential just outside the shell?
- b.) What is the **NET** electrostatic potential just inside the shell?
- c.) What is the **NET** electrostatic potential at the center of the shell (at Q_1)?
- d.) Determine the constant of integration when calculating the **NET** electrostatic potential inside the inner the wall of the shell.
- e.) What is the **NET** electrostatic potential 3.00 cm from the central charge?
- f.) Where, other than infinity, will the **NET** electrostatic potential be zero?
- g.) On the graph below, sketch the electric field strength as a function of distance, r , from Q_1 .
- h.) On the graph below and to the right, sketch the electric potential as a function of distance, r , from Q_1 .

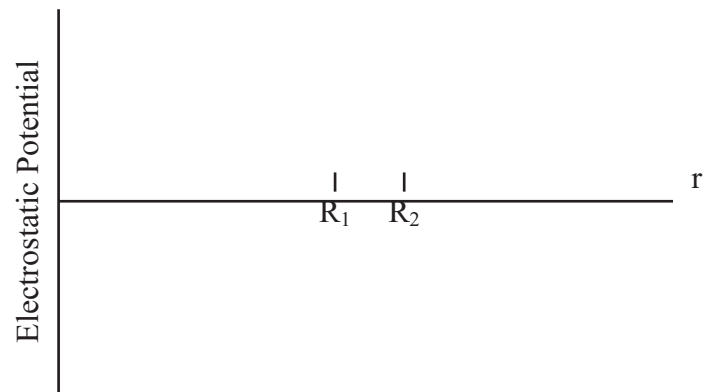
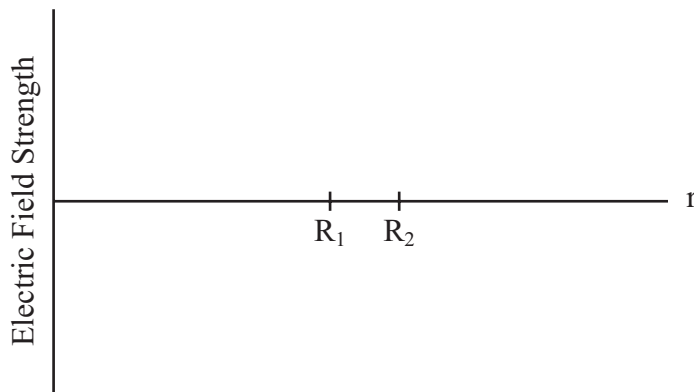

ANSWERS: **03.** a.) $8.10 \times 10^5 \text{ V}$ b.) $8.10 \times 10^5 \text{ V}$ c.) ∞ d.) $1.3725 \times 10^6 \text{ V}$ e.) $-1.275 \times 10^5 \text{ V}$
03. f.) 3.28 cm from Q_1

Engineering Electrostatics: Continuous Charge Distributions

Electric Field & Potential of Multiple Charged Objects Homework # 110

III

04. Each of the three vertical, parallel, conducting plates shown in the diagram to the right has an area of 2.00 m^2 . The first plate contains a charge of $Q_1 = +8.00 \mu\text{C}$ and is located at $x = -0.400 \text{ m}$. The second plate contains a charge of $Q_2 = -8.00 \mu\text{C}$ and is located at $x = -0.200 \text{ m}$. The third plate contains a charge of $Q_3 = +4.00 \mu\text{C}$ and is located at $x = 0.200 \text{ m}$. Assume the **NET** electric potential is zero at the origin.

- Determine the **NET** electric field to the left of plate 1.
- Determine the **NET** electric field between plates 1 and 2.
- Determine the **NET** electric field between plates 2 and 3.
- Determine the **NET** electric field to the right of plate 3.
- Determine the **NET** electric potential of each plate (V_1 , V_2 , and V_3).
- Where, other than the origin, is the **NET** electric potential zero?
- On the graph below, sketch the potential as a function of position along the x -axis.
- What is the potential difference between plates 1 and 2?
- How much work would be required to move an electron from plate 3 to plate 1?

Problem 04

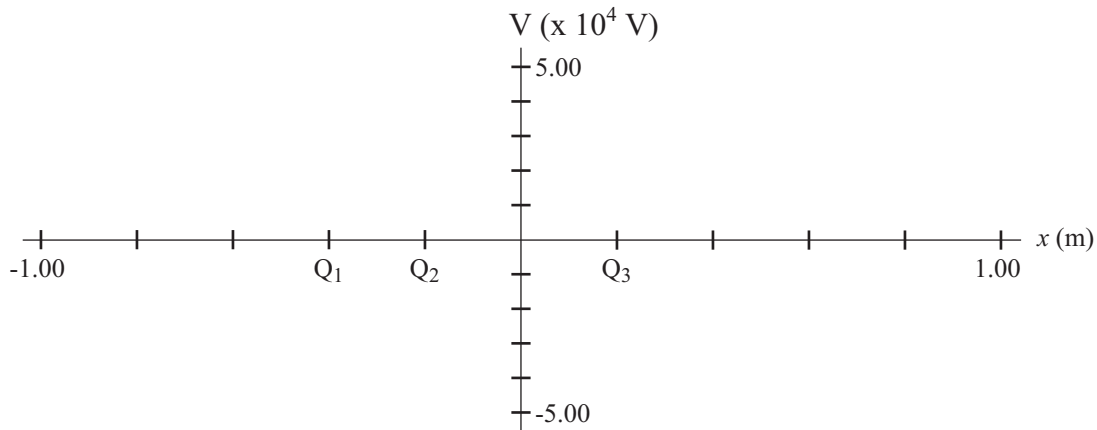
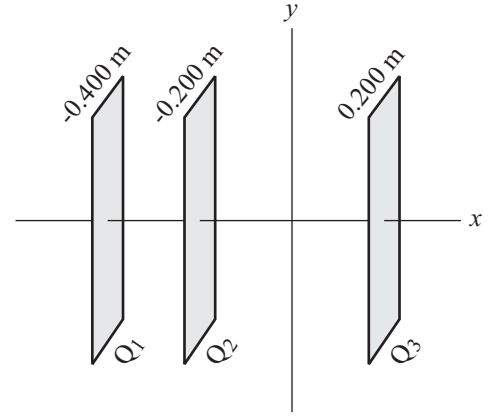

ANSWERS: **04.** a.) $-1.13 \times 10^5 \text{ N/C}$ b.) $3.39 \times 10^5 \text{ N/C}$ c.) $-1.13 \times 10^5 \text{ N/C}$ d.) $1.13 \times 10^5 \text{ N/C}$
04. e.) $V_1 = 4.52 \times 10^4 \text{ V}$, $V_2 = -2.26 \times 10^4 \text{ V}$, $V_3 = 2.26 \times 10^4 \text{ V}$ f.) $x = -0.800 \text{ m}$, -0.267 m , 0.400 m
04. h.) $6.78 \times 10^4 \text{ V}$ i.) $3.62 \times 10^{-15} \text{ J}$

DC Electric Circuits

Homework # 111

Resistivity and Temperature Coefficients (at 20 °C)

Substance	Resistivity, ρ ($\Omega \cdot m$)	Temperature Coefficient, α ($^{\circ}C$) ⁻¹
<i>Conductors</i>		
Silver	1.59×10^{-8}	0.0061
Copper	1.68×10^{-8}	0.0068
Aluminum	2.65×10^{-8}	0.00429
Tungsten	5.6×10^{-8}	0.0045
Iron	9.71×10^{-8}	0.00651
Platinum	10.6×10^{-8}	0.003927
Mercury	98×10^{-8}	0.0009
Nichrome (alloy of Ni, Fe, Cr)	100×10^{-8}	0.0004
<i>Semiconductors</i>		
Carbon (graphite)	$(3-60) \times 10^{-5}$	-0.0005
Germanium	$(1-500) \times 10^{-5}$	-0.05
Silicon	0.1 - 60	-0.07
<i>Insulators</i>		
Glass	$10^9 - 10^{12}$	
Hard Rubber	$10^{13} - 10^{15}$	

American Wire Gauge

AWG Gauge	Diameter (Inches)	Diameter (mm)	Cross Sectional Area (mm ²)
10	0.0109	2.58826	5.26145
12	0.0808	2.05232	3.30811
14	0.0641	1.62814	2.08196
16	0.0508	1.29032	1.30763
18	0.0403	1.02362	0.82294
20	0.0320	0.81280	0.51887
22	0.0254	0.64516	0.32691
24	0.0201	0.51054	0.20471
26	0.0159	0.40386	0.12810
28	0.0126	0.32004	0.08044
30	0.0100	0.25400	0.05067
32	0.0080	0.20320	0.03243
34	0.0063	0.16002	0.02011

Resistor Color Code

Color	Number	Multiplier	Tolerance
Black	0	1	
Brown	1	10^1	
Red	2	10^2	
Orange	3	10^3	
Yellow	4	10^4	
Green	5	10^5	
Blue	6	10^6	
Violet	7	10^7	
Gray	8	10^8	
White	9	10^9	
Gold		10^{-1}	5%
Silver		10^{-2}	10%
No Color			20%

DC Electric Circuits

Voltage, Current, Resistance, & Ohm's Law

Homework # 112

See [Homework #111](#) for Tables on Resistivity and American Wire Gauge.

I

- A battery charger charges a battery with a current of 3.25 A for 3.00 h.
 - How much charge passes through the battery?
 - How many electrons are transferred to the battery?
- Nerve cells "communicate" with each other via varying the potential difference between the two sides of a neuron's (nerve cell) cell wall. What is the current if 1200 Na⁺ ions flow across a cell membrane in 4.25 μs? A sodium ion has 11 protons, 11 neutrons, and 10 electrons so it has one more proton than electrons.
- What is the resistance of a heater if it produces a current of 15.0 A when plugged into a household outlet that is wired for 120 V?
- A 1.50-V flashlight battery (D cell) is placed in a flashlight whose bulb has a resistance of 1.35 Ω. How many electrons leave the battery if the flashlight is left on for 10.0 minutes?
- What is the resistance of a 14-Gauge copper wire that is 4.75 m long?
- What is the diameter of a 75.0-cm length of tungsten wire whose resistance is 0.350 Ω?

II

- An electrical device draws 2.65 A at 120 V. In the summertime, demand for power in the community can cause the voltage to drop by 10.0%. If the voltage drops by this amount, how much current will this device draw?
- A bird stands on an electric transmission line carrying 1500 A. The line has 1.85 x 10⁻⁵ Ω resistance per meter. If the bird's feet are 3.00 cm apart, how much voltage does it feel.
- A 50.0-m long wire with a diameter of 1.60 mm has a resistance of 5.6 Ω. What is the resistance of a 90.0-m length of wire with a diameter of 4.10 mm made of the same material?
- What diameter of tungsten wire must be made to have the same resistance as an equal length of 2.40-mm-diameter copper wire?
- How much would the temperature of a copper wire, initially at 20.0°C, have to be raised to increase its resistance by 35%?

- A 100-W light bulb has a resistance of 12.0 Ω when cold and 140 Ω when on (hot). If the average temperature coefficient of resistivity, α, is 0.0060(C°)⁻¹, approximate the temperature of the filament when the bulb is "on".

III

- Copper has approximately 10²⁹ free electrons per cubic meter. What is the approximate average velocity of electrons in a 1.00 mm radius wire carrying 1.00 A?

ANSWERS: **01.** a.) 35,100 C b.) 2.19 x 10²³ **02.** 4.52 x 10⁻¹¹ A **03.** 8.00 Ω **04.** 4.17 x 10²¹
05. 0.0383 Ω **06.** 0.391 mm **07.** 2.39 A **08.** 8.10 x 10⁻⁴ V **09.** 1.54 Ω **10.** 4.38 mm **11.** 51.5°C
12. 1800°C **13.** 1.99 x 10⁻⁵ m/s

DC Electric Circuits

Electric Power

Homework # 113

I

01. What is the current through a 60.0-W light bulb wired (via a lamp to an outlet) to a 120-V power source (American household)?
02. The element of an electric oven that is designed to produce 3.00 kW of heat when wired to a 240-V source. What is the resistance of this element?
03. A 9.00-V transistor radio draws a maximum of 300 mA of current. What is the maximum power consumption of this radio?
04. If the starter motor in an automobile draws 150 A from the 12.0-V battery, how much power is being consumed?
05. What is the maximum voltage that can be applied across a 500- Ω resistor rated at $\frac{1}{2}$ W?

II

06. A woman vacuums the house for 45.0 minutes using a vacuum cleaner rated at drawing 12.0 A on 120-V line.
 - a.) How many kWh does a vacuum cleaner use?
 - b.) If the electric company charges \$0.0984 per kWh, how much did this woman cost her husband by using an electric vacuum, instead of a little elbow grease (such as a mechanical sweeper)?
07. A physics student wishes to see how many 100-W light bulbs will be required to blow the 15.0-A fuse that the room in which his experiment is conducted is wired. Assuming he has unlimited lamps, 120-V outlets, and 100-W light bulbs, what is the maximum number of bulbs that can be used without blowing the fuse?
08. What is the total amount of energy stored in a 12.0-V, 40.0-A•h car battery that is fully charged?
09. What is the efficiency of a 5.00-hp electric motor that draws 18.8 A from a 240-V line?
10. A power station delivers 520 kW of power to a town through power lines that have a net resistance of 2.85 Ω .
 - a.) How much power is wasted as heat generated in the power lines if the power is delivered at 2400 V?
 - b.) How much power is wasted as heat generated in the power lines if the power is delivered at 48,000 V?

III

11. The current in an electromagnet connected to a 240-V line is 8.25 A. At what rate must cooling water pass of the coils of the electromagnet if the water temperature is to rise by no more than 8.00°C?
12. A small immersion heater is designed to plug into the lighter accessory of a car and heat a cup of water for coffee. If the temperature of 220 mL of water increases from 6.00°C to 93.5°C in 7.50 minutes, how much current does it draw from the 12.0-V car battery?

ANSWERS: **01.** 0.500 A **02.** 19.2 Ω **03.** 2.70 W **04.** 1800 W **05.** 15.8 V **06.** a.) 1.08 kWh b.) \$0.106
07. 18.0 bulbs **08.** 1.73 x 10⁶ J **09.** 83.1% **10.** a.) 134 kW b.) 0.334 kW **11.** 0.0592 kg/s (213 kg/h)
12. 14.9 A

DC Electric Circuits

Alternating Current

Homework # 114

I

01. An ac voltage supply with a peak voltage of 180 V is applied across a 480- Ω resistor.
a.) What is the value of the peak current in the resistor?
b.) What is the value of the rms current in the resistor?
02. What is the peak current in a 2.80-k Ω resistor connected to a 240-V ac power source?
03. Determine the resistance of the following 120-V_{rms} light bulbs.
a.) 40.0 W b.) 60.0 W c.) 75.0 W d.) 100 W

II

04. What is the peak current passing through a 100-W light bulb connected to a 120-V ac line?
05. If the peak value of alternating current passing through a 1250-W electric device is 4.25 A, what is the rms voltage across it?
06. What is the maximum instantaneous value of the power dissipated by a 75.0-W light bulb?
07. A 15.0- Ω heater coil is connected to a 240-V ac line.
a.) What is the average power used by this coil?
b.) What is the maximum value of the instantaneous power?
c.) What is the minimum value of the instantaneous power?

ANSWERS: **01.** a.) 0.530 A b.) 0.375 A **02.** 0.121 A **03.** a.) 360 Ω b.) 240 Ω c.) 192 Ω d.) 144 Ω
04. 1.18 A **05.** 416 V **06.** 150 W **07.** a.) 3840 W b.) 7680 W c.) 0 W

DC Electric Circuits

Resistors in Series & Parallel

Homework # 115

II

01. Each cell of the circuit shown to the right has an emf of 1.50 V.
- What is the net emf of the circuit?
 - What is the net resistance of the circuit?
 - What is the current through each cell of the battery?
 - Determine the current through each resistor.
 - What is the voltage, V_2 , across resistor R_2 ?
 - What is the power generated by the battery V_1 ?
 - What is the power generated by the battery V_2 ?
 - What is the power generated by this combination of batteries?
 - What is the power consumption of resistor R_3 in this circuit?
 - At what rate is energy transformed by resistor R_4 ?
 - What is potential difference between points A and B?
 - What is the potential difference between points A and C?

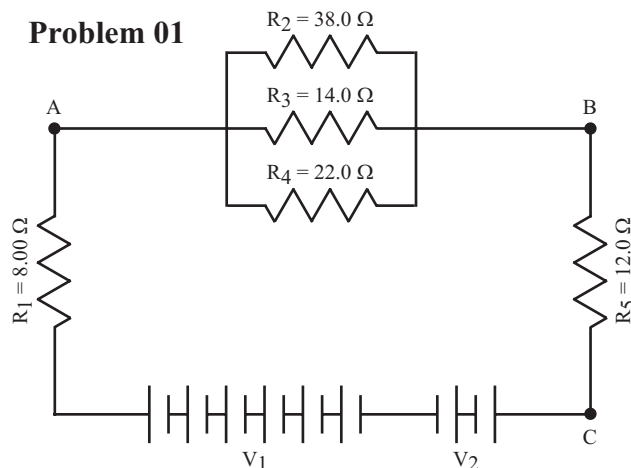

02. Each cell of the circuit shown to the right has an emf of 1.50 V.
- What is the net emf of the circuit?
 - What is the net resistance of the circuit?
 - Determine the current through each resistor.
 - What is the voltage, V_2 , across resistor R_2 ?
 - What is the power consumption of resistor R_3 in this circuit?

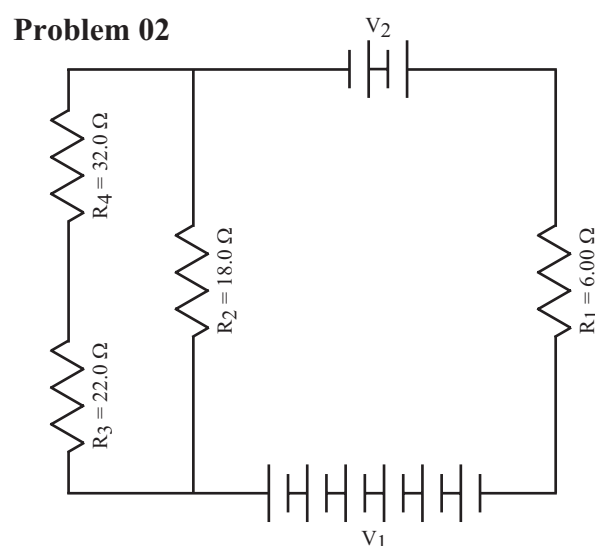

03. Assume all of the light bulbs in the circuit shown below are identical, each with a resistance of R .
- What is the net resistance of the circuit?
 - Determine the current through each light bulb.
 - What is the voltage, V_4 , across light bulb L_4 ?
 - What is the power consumption of light bulb L_3 in this circuit?

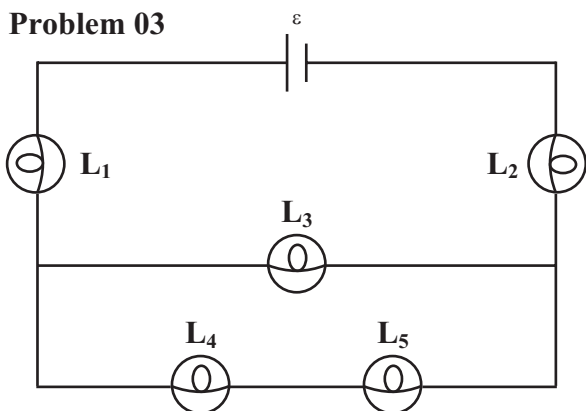

ANSWERS: **01.** a.) 6.00 V b.) 27.0 Ω c.) 0.222 A

01. d.) $I_1 = I_5 = 0.222$ A, $I_2 = 0.0409$ A, $I_3 = 0.111$ A, $I_4 = 0.0707$ A e.) 1.56 V f.) 2.00 W g.) 0.667 W

01. h.) 1.33 W i.) 0.172 W j.) 0.110 W k.) 1.56 V l.) 4.22 V **02.** a.) 12.0 V b.) 19.5 Ω

02. c.) $I_1 = 0.615$ A, $I_2 = 0.461$ A, $I_3 = I_4 = 0.154$ A d.) 8.30 V e.) 0.520 W **03.** a.) $\frac{8}{3}R$

03. b.) $I_1 = I_2 = \frac{3}{8} \frac{\epsilon}{R}$, $I_3 = \frac{1}{4} \frac{\epsilon}{R}$, $I_4 = I_5 = \frac{1}{8} \frac{\epsilon}{R}$ c.) $V_4 = \frac{1}{8} \epsilon$ d.) $P_3 = \frac{1}{16} \frac{\epsilon^2}{R}$

DC Electric Circuits

EMF & Terminal Voltage

Homework #116

I

01. In an experiment to determine the internal resistance of a battery, a physics student measures the voltage of the battery with no load to be 12.00 V. When connected a circuit drawing a current to measured to be 0.850 A, the voltage is now recorded as 11.60 V. What is the internal resistance of the battery?
02. A battery with an emf of 18.0 V and an internal resistance of $0.650\ \Omega$ is connected to a circuit with a net resistance of $23.8\ \Omega$. What will the current be through the load?
03. A battery with an emf of 6.00 V and an internal resistance of $0.350\ \Omega$ is wired to a circuit with a net resistance of $10.80\ \Omega$ (not including the internal resistance of the battery). What is the terminal voltage of the battery.

II

04. A battery charger with an emf of 30.0 V and an internal resistance of $0.800\ \Omega$ is used to charge a 12.0-V car battery with an internal Resistance of $0.900\ \Omega$ for 40.0 minutes. [Note: To charge the battery the charger and battery are wired in series with their negative terminals wired together and their positive terminals wired together. In other words, the voltage of each power source is driving current in opposite directions in the circuit.]
 - a.) How much charge will the battery have received from the charger?
 - b.) How many electrons will the battery have received?

05. Each cell of the circuit shown to the right has an emf of 2.20 V and an internal resistance of $0.6\ \Omega$.
 - a.) What is the net emf of the circuit?
 - b.) What is the total internal resistance of the batteries in this circuit?
 - c.) What is the net resistance of the loads in the circuit (exclude the internal resistance of the batteries)?
 - d.) What is the net resistance of the circuit?
 - e.) What is the voltage, V_5 , across resistor R_5 .
 - f.) What is the power consumption of resistor R_7 .

Problem 05

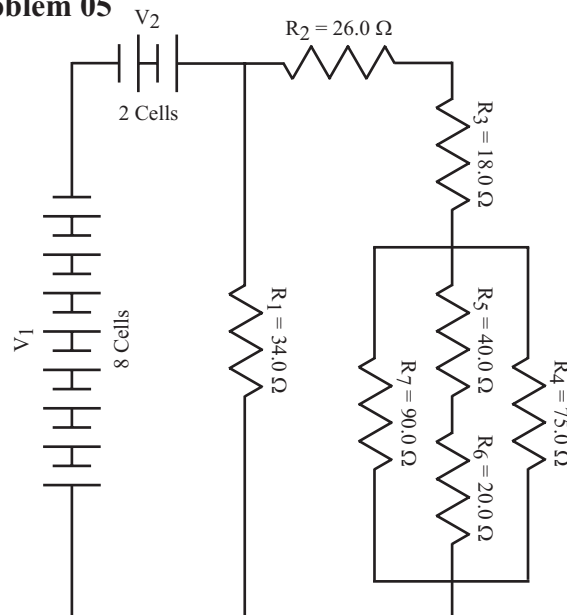

06. Assume both batteries (bottom-right circuit) are identical, each with an emf of 4.50 V and an internal resistance of $0.800\ \Omega$. The load is a variable resistor (can be adjusted to any resistance).

For parts a.) through f.), assume the load is $9.60\ \Omega$.

- a.) What is the net emf of the circuit?
- b.) What is the current to the load?
- c.) How much power would be consumed by the load?
- d.) How much power is being supplied by the batteries?
- e.) How much power is being consumed by the internal resistance of the batteries?
- f.) With what efficiency is power being delivered to the load?

For parts g.) and h.), adjust the resistance to one that will provide maximum power to the load.

- g.) What resistance would provide the maximum power to the load?
- h.) What would be this maximum power delivered to the load?

Problem 06

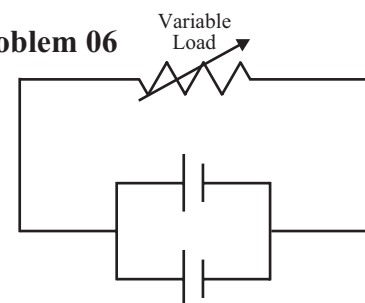

ANSWERS: 01. $0.471\ \Omega$ 02. $0.736\ \text{A}$ 03. $5.81\ \text{V}$ 04. a.) $2.54 \times 10^4\ \text{C}$ b.) 1.59×10^{23}
 05. a.) $13.2\ \text{V}$ b.) $6.00\ \Omega$ c.) $22.7\ \Omega$ d.) $28.7\ \Omega$ e.) $2.48\ \text{V}$ f.) $0.153\ \text{W}$
 06. a.) $4.50\ \text{V}$ b.) $0.450\ \text{A}$ c.) $1.94\ \text{W}$ d.) $2.03\ \text{W}$ e.) $0.0810\ \text{W}$ f.) 96.0% g.) $0.400\ \Omega$ h.) $12.7\ \text{W}$

DC Electric Circuits

Kirchhoff's Rules

Homework # 117

II

01. In the circuit shown to the right, $V_1 = 80.0 \text{ V}$ and $V_2 = 120.0 \text{ V}$.

Ignore any internal resistance in the power supplies.

- a.) What is the current through resistor R_1 ?
- b.) What is the current through resistor R_2 ?
- c.) What is the current through resistor R_3 ?
- d.) What is the current through resistor R_4 ?
- e.) What is the current through resistor R_5 ?
- f.) What is the current through resistor R_6 ?
- g.) What is the voltage across resistor R_4 ?
- h.) What is the power consumption of resistor R_6 ?
- i.) What is the power generated by battery V_1 ?
- j.) What is the potential difference between points A and C?
- k.) What is the potential difference between points B and C?

Problem 01

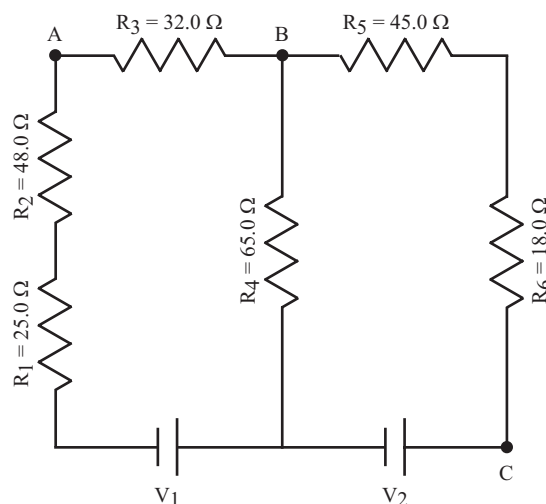

02. In the circuit shown to the right, $V_1 = 60.0 \text{ V}$, $V_2 = 45.0 \text{ V}$ and $V_3 = 75.0 \text{ V}$. Ignore any internal resistance in the power supplies.

- a.) What is the current through resistor R_1 ?
- b.) What is the current through resistor R_2 ?
- c.) What is the current through resistor R_3 ?
- d.) What is the current through resistor R_4 ?
- e.) What is the current through resistor R_5 ?
- f.) What is the current through resistor R_6 ?
- g.) What is the current through resistor R_7 ?
- h.) What is the current through resistor R_8 ?
- i.) What is the voltage across resistor R_3 ?
- j.) What is the power consumption of resistor R_6 ?
- k.) What is the power generated by battery V_1 ?
- l.) What is the potential difference between points A and B?

Problem 02

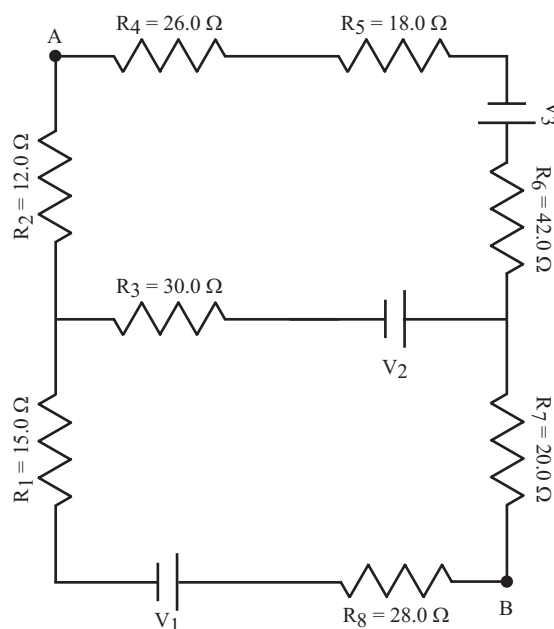

ANSWERS: **01.** a.) 1.03 A b.) 1.03 A c.) 1.03 A d.) 0.431 A e.) 1.46 A f.) 1.46 A g.) 28.0 V
01. h.) 38.4 W i.) 82.3 W j.) 125 V k.) 92.0 V **02.** a.) 0.0927 A b.) 0.213 A c.) 0.305 A
02. d.) 0.213 A e.) 0.213 A f.) 0.213 A g.) 0.0927 A h.) 0.0927 A i.) 9.16 V j.) 1.90 W
02. k.) 5.56 W l.) 58.6 V

DC Electric Circuits

Capacitors in Series & Parallel

Homework # 118

I

01. Six $7.20\text{-}\mu\text{F}$ are to be used in a circuit.
- What is their equivalent capacitance if they are connected in series?
 - What is their equivalent capacitance if they are connected in parallel?
02. A technician wants to change a circuit containing a 6400-pF capacitor to one with a capacitance of 8850 pF .
- How should an additional capacitor be added (in series or parallel) to achieve this goal?
 - What size capacitor should be added to the circuit to achieve this goal?
03. The capacitance of a portion of a circuit is to be reduced from $0.3400\text{-}\mu\text{F}$ to $0.1800\text{-}\mu\text{F}$.
- How should an additional capacitor be added (in series or parallel) to achieve this goal?
 - What size capacitor should be added to the circuit to achieve this goal?

II

04. A circuit is constructed as shown in the diagram to the right.
- What is the equivalent capacitance of the circuit?
 - What is the total charge stored on the capacitors of this circuit?
 - What is the total energy stored on the capacitors of this circuit?
 - What is the charge, Q_1 , stored on capacitor C_1 ?
 - What is the voltage, V_1 , across capacitor C_1 ?
 - What is the energy stored, E_1 , on capacitor C_1 ?
 - What is the charge, Q_2 , stored on capacitor C_2 ?
 - What is the voltage, V_2 , across capacitor C_2 ?
 - What is the energy stored, E_2 , on capacitor C_2 ?
 - What is the charge, Q_3 , stored on capacitor C_3 ?
 - What is the voltage, V_3 , across capacitor C_3 ?
 - What is the energy stored, E_3 , on capacitor C_3 ?
 - What is the charge, Q_4 , stored on capacitor C_4 ?
 - What is the voltage, V_4 , across capacitor C_4 ?
 - What is the energy stored, E_4 , on capacitor C_4 ?
 - What is the charge, Q_5 , stored on capacitor C_5 ?
 - What is the voltage, V_5 , across capacitor C_5 ?
 - What is the energy stored, E_5 , on capacitor C_5 ?

Problem 04

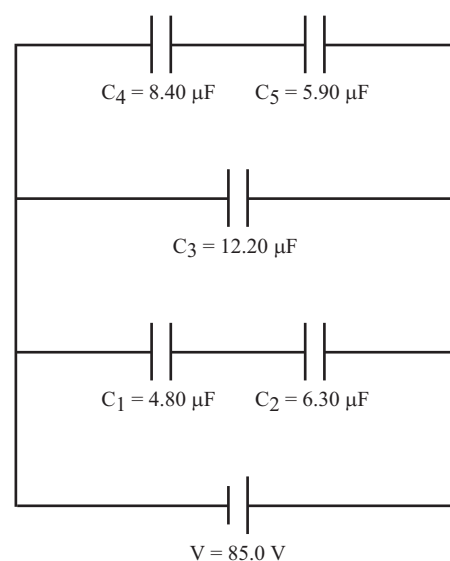

Problem 06

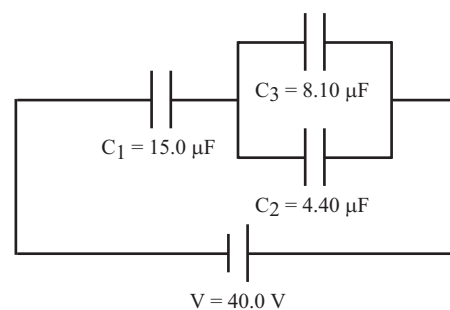

05. Three capacitors of capacitance 1800 pF , $0.02\text{ }\mu\text{F}$, and 3400 pF are available to be used in a circuit in any arrangement desirable.
- Describe arrangement and amount for maximum capacitance.
 - Describe arrangement and amount for minimum capacitance.
06. A circuit is constructed as shown in the diagram to the right.
- Determine the equivalent capacitance for the circuit.
 - What is the charge and voltage on each capacitor?

ANSWERS: **01.** a.) $1.20\text{ }\mu\text{F}$ b.) $43.2\text{ }\mu\text{F}$ **02.** a.) parallel b.) $2450\text{ }\mu\text{F}$ **03.** a.) series b.) $0.3825\text{ }\mu\text{F}$
04. a.) $18.39\text{ }\mu\text{F}$ b.) 1.56 mC c.) 66.4 mJ d.) $231\text{ }\mu\text{C}$ e.) 48.2 V f.) 5.57 mJ g.) $231\text{ }\mu\text{C}$ h.) 36.7 V
04. i.) 4.24 mJ j.) 1.03 mC k.) 85.0 V l.) 44.1 mJ m.) $295\text{ }\mu\text{C}$ n.) 35.1 V o.) 5.18 mJ p.) $295\text{ }\mu\text{C}$
04. q.) 50.0 V r.) 7.37 mJ **05.** a.) parallel ($25,200\text{ pF}$) b.) series (1112 pF) **06.** a.) $6.82\text{ }\mu\text{F}$
06. b.) $Q_1 = 273\text{ }\mu\text{C}$, $V_1 = 18.2\text{ V}$; $Q_2 = 96.0\text{ }\mu\text{C}$, $V_2 = 21.8\text{ V}$; $Q_3 = 177\text{ }\mu\text{C}$, $V_3 = 21.8\text{ V}$

DC Electric Circuits

Resistor-Capacitor (RC) Circuits

Homework # 119

II

01. A capacitor is wired to a power supply until it is fully charged, at which time it is disconnected and wired, in series, to a switch (open initially), a galvanometer, and a resistor with a resistance of $18.0\text{ k}\Omega$. The galvanometer is actually a computer generated galvanometer that is connected to the circuit via sensors and an interface box. The switch is closed and the computer graphs the current discharging from the capacitor as a function of time. This graph is shown to the right.

- What was the initial current flow out of the capacitor?
- Graphically estimate the total charge initially stored on the capacitor.
- What is the time constant for this circuit?
- Write an equation that describes the current flow out of the capacitor as a function of time.
- What was the current flow at 80.0 s after the switch was closed?
- What is the initial voltage across the capacitor?
- Write an equation that describes the voltage across the capacitor as a function of time.
- What was the voltage across the capacitor at 20.0 s after the switch was closed?
- What is the capacitance of this capacitor?
- Calculate the total charge initially stored on the capacitor.
- Write an equation that describes the charge on the capacitor as a function of time.
- What was the charge on the capacitor at 20.0 s after the switch was closed?

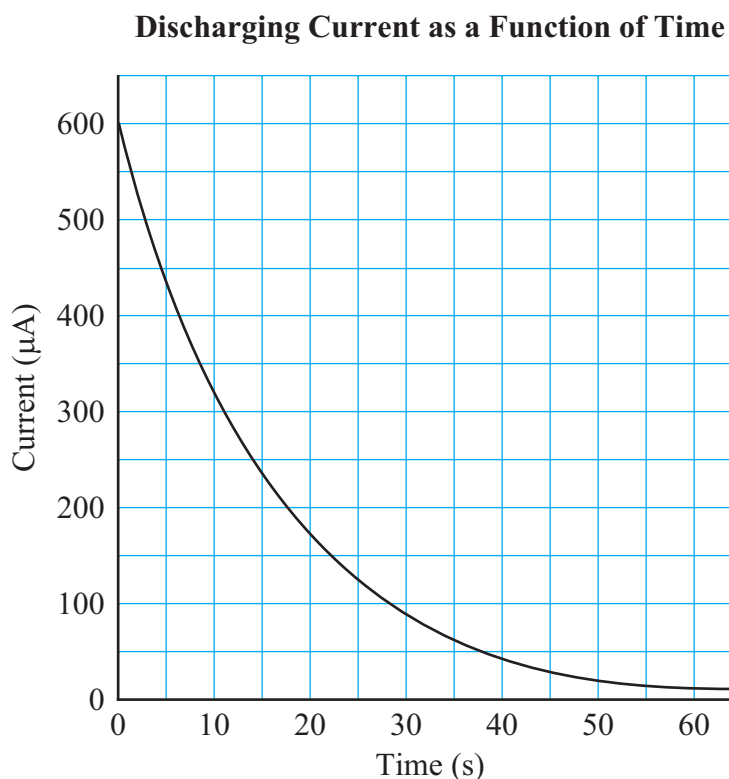

02. A capacitor which has a capacitance of $640\text{ }\mu\text{F}$ is placed in series with a 9.00-V battery, a $2100\text{ }\Omega$ resistor, and a switch as shown in the circuit to the right. Initially, the capacitor has no charge on it. The moment the switch is closed, a stopwatch is started.

- What is the time constant for this circuit?
- What is the initial current flow in this circuit?
- Write an equation that describes the current flow out of the capacitor as a function of time.
- What is the current flow after 2.40 s ?
- How long will it take for the current to drop to 1.00% of its original value?
- What charge will have accumulated on the capacitor after 2.40 s ?
- What will be the voltage across the capacitor after 4.80 s ?

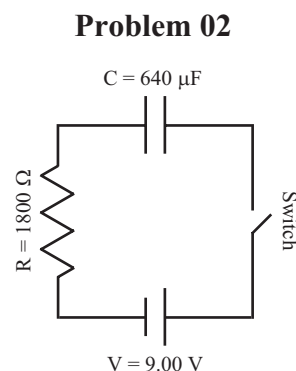

ANSWERS: **01.** a.) $600\text{ }\mu\text{A}$ b.) 9500 mA c.) 16.0 s d.) $I = (600\text{ }\mu\text{A})e^{-t/16.0}$ e.) $4.04\text{ }\mu\text{A}$ f.) 10.8 V

01. g.) $V = (10.8\text{ V})e^{-t/16.0}$ h.) 3.09 V i.) $889\text{ }\mu\text{F}$ j.) 9.60 mC k.) $Q = (9.60\text{ mC})e^{-t/16.0}$ l.) 2.75 mC

02. a.) 1.34 s b.) 4.29 mA c.) $I = (4.29\text{ mA})e^{-t/1.34}$ d.) 0.719 mA e.) 6.17 s f.) 4.80 mC g.) 8.75 V

DC Electric Circuits

DC Ammeters and Voltmeters

Homework # 120

I

01. What is the resistance on a 10.0-V scale if the meter sensitivity is 25,000 Ω/V ?
02. An ammeter has a sensitivity of 10,000 Ω/V and a full-scale deflection when 100 mV is across it. What minimum current passing through the galvanometer causes full-scale deflection?

II

03. A galvanometer has a full-scale deflection of 160 μA when 10 mV are across it.
- How could this galvanometer be used to make an ammeter with a full-scale deflection of 1.00 A?
 - How could this galvanometer be used to make an ammeter with a full-scale deflection of 10.0 A?
 - How could this galvanometer be used to make an voltmeter with a full-scale deflection of 5.00 V?
 - How could this galvanometer be used to make an voltmeter with a full-scale deflection of 15.0 V?
04. A galvanometer has a sensitivity of 40,000 Ω/V and an internal resistance of 24.0 Ω .
- How could this galvanometer be used to make an ammeter with a full-scale deflection of 10.0 mA?
 - How could this galvanometer be used to make an voltmeter with a full-scale deflection of 10.0 mV?
05. A milliammeter consists of a 0.250 Ω resistor in parallel with a 40.0 Ω galvanometer. It has a full-scale deflection of 50.0 mA.
- How can this ammeter be used to construct a voltmeter with full-scale deflection of 10.0 V with out changing the structure of the ammeter (taking it apart)?
 - What will be the sensitivity of the voltmeter constructed in part a.) above?

ANSWERS: **01.** 250 k Ω **02.** 100 μA **03.** a.) 0.0100 Ω (shunt resistor) b.) 0.00100 Ω (shunt resistor)
03. c.) 31.1 k Ω (series resistor) d.) 93.6 k Ω (series resistor)
04. a.) 0.0601 Ω (shunt resistor) b.) 376 Ω (series resistor) **05.** a.) 200 Ω b.) 20 Ω/V (terrible sensitivity)

DC Electric Circuits

DC Electric Circuits Review

Homework # 121

II

01. Each of the following questions refers to the diagram to the right. Assume all light bulbs are identical (equal resistances of R) and the battery has a **NET** voltage of V (ignore internal resistance). For each of the following, supply a clear explanation! Mathematically support your answers!

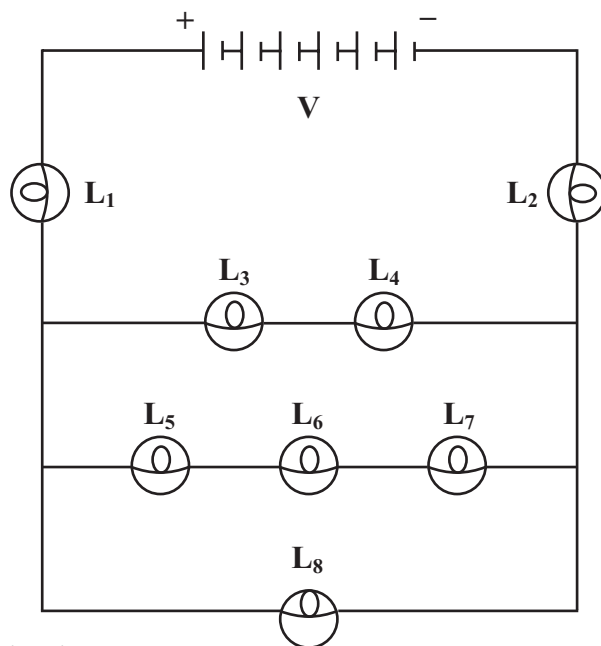

- a.) How will the currents ($I_1, I_2, I_3, I_6,$ and I_8) through light bulbs $L_1, L_2, L_3, L_6,$ and $L_8,$ respectively, compare? Explain!
- b.) How will the readings on a voltmeter ($V_3, V_4,$ and V_5) connected across each of light bulbs $L_3, L_4,$ and L_5 compare? Explain!
- c.) How will the readings on a voltmeter ($V_1, V_2,$ and V_8) connected across each of the light bulbs L_1, L_2 and L_8 be related? Explain!
- d.) Suppose that an ammeter is connected in parallel with light bulb L_6 . Describe **exactly** what will happen to all of the light bulbs in the circuit and why! Be sure to describe **ALL** changes in the circuit!
- e.) Suppose that a voltmeter is connected in series with light bulb L_8 . Describe **exactly** what will happen to all of the light bulbs in the circuit and why! Be sure to describe **ALL** changes in the circuit!
- f.) How will the voltages ($V_5, V_7,$ and V_8) across light bulbs $L_5, L_7,$ and L_8 compare? Explain!
- g.) How does the currents ($I_3, I_5,$ and I_8) through light bulbs $L_3, L_5,$ and L_8 compare? Explain!

02. Consider a battery, made up of 4 cells connected in series, which is in turn connected in parallel with 4 other cells in series as shown in the diagram to the right. **Each** cell has an internal resistance of 0.250Ω and an EMF of 2.02 Volts. This battery, in turn, is connected to a load resistance R . Assume the load resistance consists of 4.85 meters of wire with a diameter of 0.356 mm and a resistivity, ρ , of $3.60 \times 10^{-7} \Omega \cdot \text{m}$.

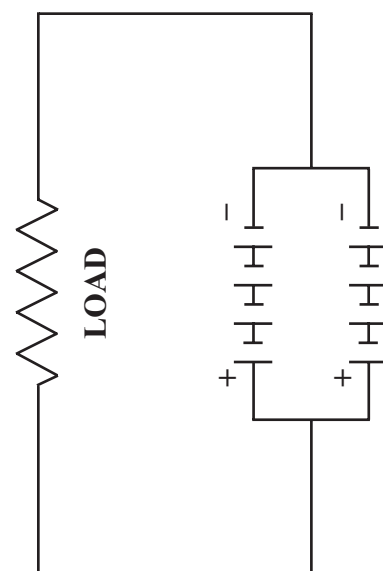

- a.) What is the resistance of this load?
- b.) What will be the magnitude of the current flowing through **each** cell of the battery? Justify!
- c.) What will be the reading on a voltmeter connected across each battery? Explain!
- d.) With what efficiency is power being delivered to this load?

Suppose that this load is replaced with some other load such that the power delivery in this circuit is maximized.

- e.) How much power will be delivered to this new load?

ANSWERS: 01. a.) $I_1 = I_2 = \frac{11}{28} \frac{V}{R} > I_8 = \frac{6}{28} \frac{V}{R} > I_3 = I_4 = \frac{3}{28} \frac{V}{R} > I_5 = I_6 = I_7 = \frac{2}{28} \frac{V}{R}$

01. b.) $V_3 = V_4 = \frac{3}{28} V > V_5 = \frac{2}{28} V$ **c.)** $V_1 = V_2 = \frac{11}{28} V > V_8 = \frac{6}{28} V$

01. d.) $I_1 = I_2 = \frac{2}{5} \frac{V}{R} > I_8 = \frac{1}{5} \frac{V}{R} > I_3 = I_4 = I_5 = I_7 = \frac{1}{10} \frac{V}{R} > I_6 = 0$

01. e.) $I_1 = I_2 = \frac{5}{16} \frac{V}{R} > I_3 = I_4 = \frac{3}{16} \frac{V}{R} > I_5 = I_6 = I_7 = \frac{2}{16} \frac{V}{R} > I_8 = 0$

01. f.) $V_8 = \frac{6}{28} V > V_5 = V_7 = \frac{2}{28} V$ **g.)** $I_8 = \frac{6}{28} \frac{V}{R} > I_3 = \frac{3}{28} \frac{V}{R} > I_5 = \frac{2}{28} \frac{V}{R}$

02. a.) 17.5Ω **b.)** 0.225 A **c.)** 7.855 V **d.)** 97.5% **e.)** 32.6 W

Magnetism & Electromagnetic Induction

Magnetic Force on a Moving Charged Particle

Homework # 123

See [Homework #92](#) in the chapter called "Electrostatics" for Information on Atomic Particles.

I

01. An electron travels eastward at 3.43×10^6 m/s into a 1.35-T magnetic field directed vertically upward.
- What is the magnitude of the magnetic force on the moving electron?
 - What is the direction of the magnetic force on the electron the moment it enters the magnetic field?
 - Describe the path of the electron in this field.

02. What is the direction of the force, F , on a positively charged particle for each diagram shown to the right, where v is the velocity of the charge and B is the direction of the magnetic field?

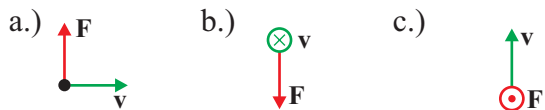

03. What is the direction of the magnetic field, B , in each diagram shown to the left, where F is the force on a positively charged particle with a velocity of v .

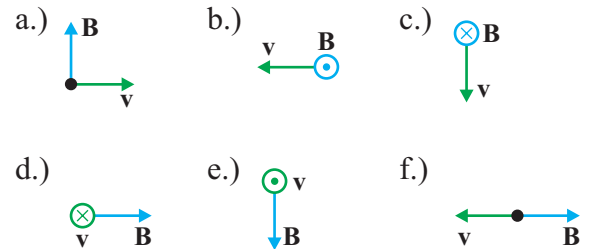

II

04. A 2.10-T magnetic field is directed to the right as shown in the diagram to the right. A proton is moving at a speed of 5.80×10^5 m/s from the bottom of the page to the top of the page.
- What is the magnitude of the magnetic force acting on the proton?
 - Describe **exactly** the path of the proton once it enters the magnetic field.
 - What is the radius of the proton's path?

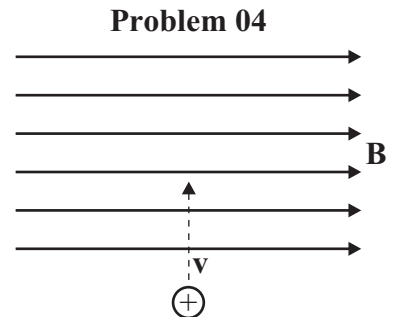

05. A charged particle moves into the page in a region of space where both an electric field, with a strength of 28,000 N/C, and a magnetic field, with a strength of 3.40 T are present. The two fields are perpendicular to each other and in the plane of the page as shown in the diagram to the right. The charged particle passes straight through the fields undeflected.
- What is the velocity of the charge?
 - Does the magnitude or sign of the charge affect the answer? If yes what magnitude and sign should the charge have to travel through this region of space undeflected?

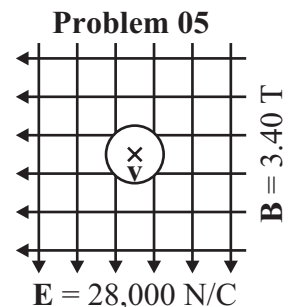

06. An alpha particle (helium nucleus) is traveling at 26,350 m/s when it enters a magnetic field, with a strength of 0.0165 T, directed toward the top of the page as shown in the diagram to the right. The initial direction of the alpha particle's path makes a 65.0° angle with the direction of the magnetic field.
- Describe **exactly** the path of the alpha particle after it enters the field.
 - What is the radius of the alpha particle's path after it enters the field?
 - What is the pitch of the alpha particle's path after it enters the field?

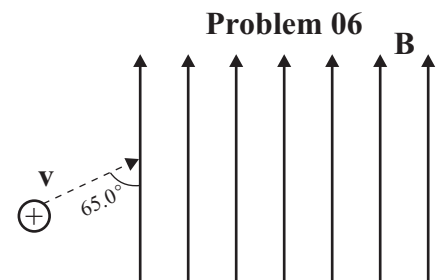

ANSWERS: **01.** a.) 7.41×10^{-13} N b.) north c.) circular **02.** a.) out of the page b.) top of the page
02. c.) right d.) bottom of the page e.) right f.) no force **03.** a.) into the page b.) right c.) left
04. a.) 1.95×10^{-13} N b.) clockwise circular path when viewed from the right c.) 2.88 mm **05.** 8235 m/s
06. a.) clockwise spiral (when viewed from above) toward the top of the page b.) 2.54 cm c.) 7.45 cm

Magnetism & Electromagnetic Induction

Magnetic Force Applications: Galvanometers-Motors (Torque) Homework # 124

I

- A galvanometer has a full-scale deflection of $50 \mu\text{A}$. If the magnetic field were to weaken to 0.800 of its original strength, what current would produce full-scale deflection?
- If the restoring spring of a galvanometer (originally with a full-scale deflection current of $80.0 \mu\text{A}$) weakens by 15.0% through years of use, what minimum current will now give full-scale deflection?
- If the current to a motor drops by 8.00%, by what factor will the output torque change?

II

- A rectangular coil, which is 16.0 cm wide and 12.0 cm high and consists of 1200 turns, is initially sitting in a magnetic field with a magnitude of $B = 4.60 \text{ T}$ as shown in the diagram to the right. A conventional current of 8.75 A is flowing counterclockwise through the coil as shown.
 - Describe **exactly** the direction of the torque acting on this coil while oriented as shown?
 - What will be the magnitude of the torque acting on this coil while oriented as shown?
 - What will be the magnitude of the torque acting on this coil when it has rotated 90.0° so that the normal to the face of the coil is parallel to the magnetic field?

Problem 04

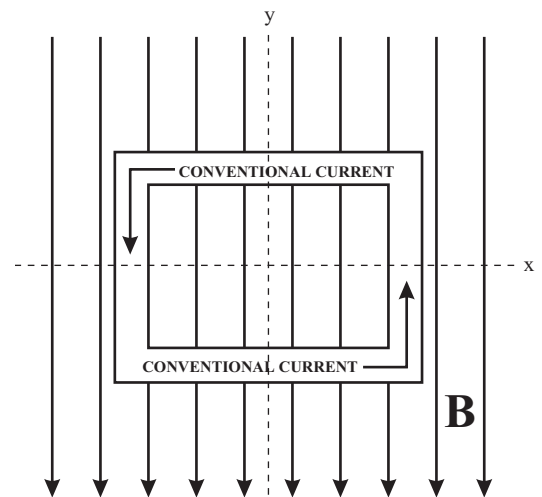

When the frequency of rotation of the coil reaches 5.20 revolutions per second, the coil no longer angularly accelerates due to a counter torque that makes the net torque zero. The coil then rotates at a constant rate of 5.20 revolutions per second. Assume the moment it reaches this state of equilibrium, the coils are oriented as shown in the diagram. Assume the current changes direction every half a turn.

- Write an equation that describes the torque created by the magnetic field as a function of time.
- What will be the torque after 12.0 s?

- The circular coil consisting of 6 turns has a diameter of 14.0 cm and is sitting in a 1.65-T magnetic field as shown in the diagram to the right. The current in the wire is 2.80 A and is clockwise.
 - What would be the resulting magnetic effect on the loop? Explain!!!
 - If the current were reversed, what would be the resulting magnetic effect on the loop? Explain!!!

Problem 05

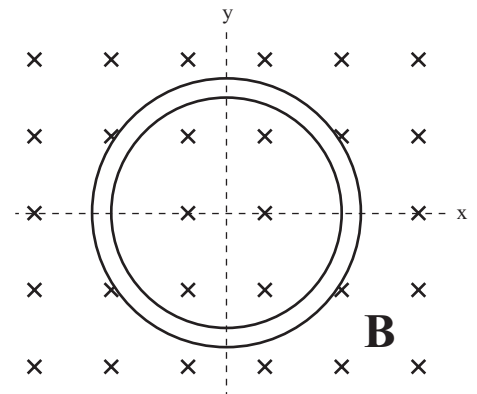

This magnetic field is removed and replaced with one directed to the right which creates a torque with a magnitude of $0.957 \text{ N}\cdot\text{m}$ when the coil is in the plane of the page as shown. The current is still 2.80 A clockwise.

- Describe **exactly** the direction of the torque acting on this coil while oriented as shown?
- What is the magnitude of the magnetic field?

ANSWERS: **01.** $40.0 \mu\text{A}$ **02.** $68.0 \mu\text{A}$ **03.** 92.0% τ_{Original}

04. a.) counterclockwise when viewed from the right b.) $927 \text{ N}\cdot\text{m}$ c.) $0 \text{ N}\cdot\text{m}$ d.) $\tau = (927) \cdot \sin(32.7t)$

04. e.) $273 \text{ N}\cdot\text{m}$ **05.** a.) expand b.) collapse c.) clockwise when viewed from above d.) 3.70 T

Magnetism & Electromagnetic Induction

Electron Properties/Thermionic Emission & Cathode-Ray Tube (CRT) Homework # 125

Electron Properties

I

01. A charged particle moves in a circle of radius 12.0 cm when it enters a 0.319-T magnetic field. A crossed 300-V/m electric field causes the path of moving charges to be straight. (Note: a crossed electric field is one that has a direction that is perpendicular to the directions of both the magnetic field and the velocity of the moving charges)
- a.) What is the velocity of this particle? b.) What is the value of q/m for this particle?
02. A beam of protons, initially traveling west, move in a circle with a radius of 4.80 cm when they encounter a 0.285-T magnetic field that is directed vertically downward into the earth.
- a.) What is the velocity of the protons?
b.) What is the direction of the electric field will straighten this path out?
b.) What is the strength of the electric field will straighten this path out?
03. A beam of electrons goes undeflected when passing through crossed magnetic ($B = 1.35 \times 10^{-3}$ T) and electric ($E = 7250$ N/C) fields.
- a.) What is the velocity of the beam of electrons?
b.) What is the radius of the beam of electrons if the electric field is removed?

II

04. An oil drop with a mass determined to be 4.46×10^{-15} kg is held at rest between two large plates separated by 1.00 cm when the potential difference between them is 390 V. How many excess electrons does this drop have?

Thermionic Emission & the CRT

I

05. Use the ideal gas model ($KE_{\text{ave}} = \frac{3}{2}kT$) to estimate the *rms* speed of a free electron in a metal at _____.
- a.) 300 K b.) 2500 K (the typical temperature of the cathode in a tube)

II

06. The potential difference between the cathode and anode in a CRT is 3500 V creating a beam of electrons directed to the right as shown in the diagram to the right and below. The beam passes through a 32.5-G magnetic field by two Helmholtz coils causing the beam to bend. This bent beam will strike one of two horizontal metal plates that are 5.00 cm apart. The original path of the beam is at a height exactly halfway between the two plates. The Helmholtz coils have a clockwise current.
- a.) What is the speed of the electrons in the beam as they pass through the hole in the anode?
b.) What is the direction of the magnetic field created by the Helmholtz coils? Draw this field direction in the diagram.
c.) Which plate will the beam of electrons hit?
d.) What is the radius of the path of electrons once they enter the magnetic field?
e.) What horizontal distance from the entry of the magnetic field will the beam travel before hitting the plate?

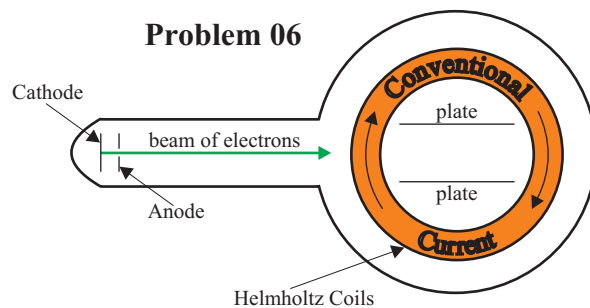

ANSWERS: **01.** a.) 940 m/s b.) 2.46×10^4 C/kg **02.** a.) 1.31×10^6 m/s b.) south c.) 3.74×10^5 N/C
03. a.) 5.37×10^6 m/s b.) 2.27 cm **04.** 7 **05.** a.) 1.17×10^5 m/s b.) 3.37×10^5 m/s
06. a.) 3.51×10^7 m/s b.) into the page c.) bottom plate d.) 6.14 cm e.) 4.95 cm

Magnetism & Electromagnetic Induction

Mass Spectrometer/Magnetic Field Strength (Ampere's Law) Homework # 126

Mass Spectrometer

I

01. In a mass spectrometer, carbon atoms have radii of curvature equal to 3.30 cm, 3.60 cm, 3.90 cm, 4.20 cm. The largest radius corresponds to a mass of 14.0 u. What are the atomic masses of the other isotopes?

II

02. Suppose the electric fields between the electric plates of a mass spectrometer is 2.82×10^4 V/m and the magnetic fields in each chamber are identical ($B_1 = B_2 = 0.850$ T). The source contains neon with mass numbers of 20 and 22 ($1 \text{ u} = 1.67 \times 10^{-27}$ kg). How far apart are the lines formed by the singly charged ions of each type on the photographic film?

III

03. A mass spectrometer is being used to monitor air pollutants. It is difficult, however, to separate molecules with nearly equal mass such as CO (28.0106 u) and N_2 (28.0134 u). If these two molecules are to be separated on the film by a distance of 0.365 mm, how large a radius of curvature must a spectrometer have?

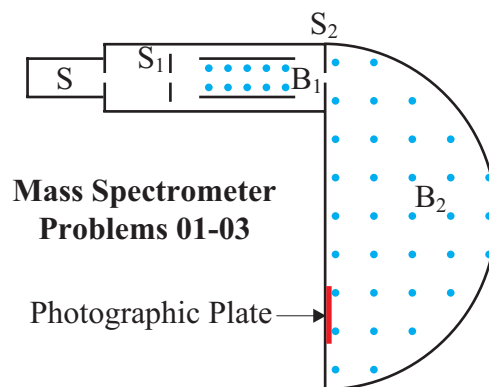

Magnetic Field Strength

I

04. How strong is the magnetic field 6.00 cm from a long straight wire carrying 4.25 A of current?
05. If a magnetic field of no more than 10.0 G is allowed 30.0 cm from an electric wire, what is the maximum current the wire can carry?

II

06. What is the acceleration of a 345-g model airplane charged to 9.15 C and traveling 1.85 m/s as it passes 8.25 cm of a wire, essentially parallel to its path, carrying a current of 37.5 A? Give the answer in g's.
07. An electron is moving 7.25×10^5 m/s towards the north. The electron is moving parallel to and directly above a straight wire carrying a 22.5-A current to the north. Initially, the electron is 8.50 cm from the wire.
- What is the direction of the magnetic field created by the current-carrying wire in the vicinity of the electron?
 - What is the direction of the initial (maximum) force on the electron from the magnetic field?
 - What is the magnitude of the initial (maximum) force on the electron from the magnetic field?

08. A 24.0-cm-long solenoid, 2.50 cm in diameter, is to produce a 0.250 T magnetic field at its center. If the maximum current is 7.95 A, how many turns must the solenoid have?

III

09. At a certain location, the earth's magnetic field has a horizontal component of 0.475 G and has a magnetic declination of 0° (magnetic north is in the exact direction of true north). A horizontal compass is placed 14.00 cm from a straight vertical wire carrying 25.0 A of current.
- In what direction will the compass needle point?
 - What is the magnitude of B_{net} at the compass?

ANSWERS: **01.** 11.0 u, 12.0 u, 13.0 u **02.** 1.63 mm **03.** 1.83 m **04.** 1.42×10^{-5} T (0.142 G) **05.** 1500 A
06. 4.55×10^{-4} g **07.** a.) east b.) up c.) 6.14×10^{-18} N **08.** 6006 turns **09.** a.) 53.1° N of E b.) 0.594 G

Magnetism & Electromagnetic Induction

Magnetic Force Between Two Parallel Wires

Homework # 127

I

01. Two horizontal straight and parallel wires 65.0 m long and 9.75 cm apart each carry 27.5 A of current directed toward the north. The two wires are at the same height so that one wire is further east than the other (by 9.75 cm).
- What is the magnitude and direction of the force on the eastern-most wire by the western-most wire?
 - What is the magnitude and direction of the force on the western-most wire by the eastern-most wire?
 - Are the forces on each of the two wires by the other wire attractive or repulsive?
02. A vertical straight carrying 11.5 A of current straight up exerts an attractive force per unit length of 8.45×10^{-4} N/m on a second parallel wire 12.75 cm away. What current (magnitude and direction) flows in the second wire?
03. Describe the direction of the magnetic field created by each of the current-carrying wires below.

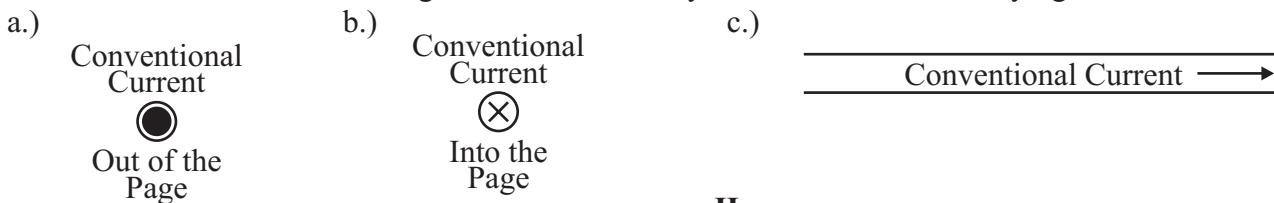

II

04. Three long parallel wires are 18.0 cm apart from one another so that they are at the three corners of the of an equilateral triangle as shown in the diagram to the right. The current in each wire is 5.00 A, but the current in wires A and B are into the page, while the current in wire C is out of the page.
- What is the **NET** magnetic force per unit length (magnitude and direction) on wire A from wires B and C?
 - What is the **NET** magnetic force per unit length (magnitude and direction) on wire B from wires A and C?
 - What is the **NET** magnetic force per unit length (magnitude and direction) on wire C from wires A and B?

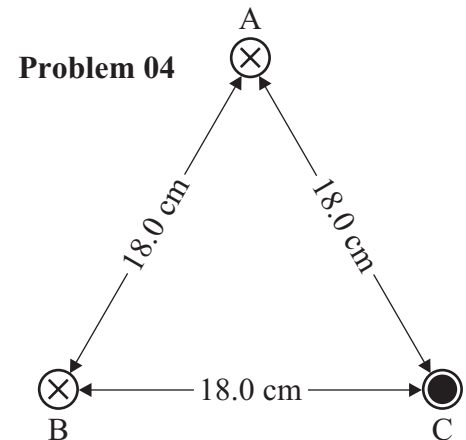

05. Two horizontal straight and parallel wires are oriented such that one is directly above the other as shown in the diagram to the right. The upper wire is made of copper ($\rho = 8900 \text{ kg/m}^3$) with a diameter 2.05 mm (Gauge 12) and is a distance of $D = 3.45 \text{ cm}$ above the lower wire. The lower wire is a power transmission wire with a current of 2450 A to the right. The current in the upper wire is such that it is suspended above the lower wire due to the magnetic repulsive force from the lower wire.

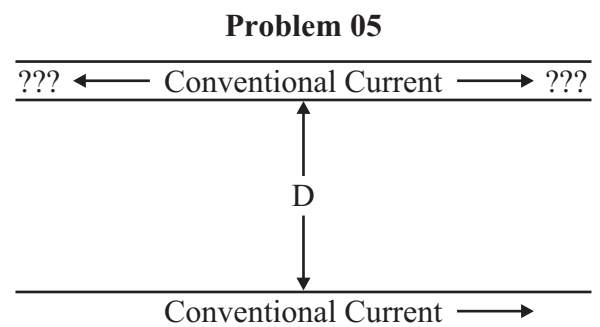

- What is the magnitude and the direction of the magnetic field at the location of the upper wire created by the lower wire?
- What is the current (magnitude and direction) in the upper wire to create repulsive forces between the wires?
- What is the **NET** magnetic field (magnitude and direction) 3.25 cm above the bottom wire?
- What is the **NET** magnetic field (magnitude and direction) 3.25 cm above the top wire?

ANSWERS: 01. a.) 0.101 N west b.) 0.101 N east c.) attractive 02. 46.8 A
 03. a.) counterclockwise b.) clockwise c.) counterclockwise (viewed from the right)
 04. a.) 2.78×10^{-5} N/m due West b.) 2.78×10^{-5} N/m 60.0° N of W c.) 4.81×10^{-5} N/m 30.0° S of E
 05. a.) 1.42×10^{-2} T b.) 20.3 A left c.) 1.71×10^{-2} T (out of the page) d.) 7.19×10^{-3} T (out of the page)

Magnetism & Electromagnetic Induction

Faraday's Law of Electromagnetic Induction

Homework # 128

I

01. A 16.0-cm diameter circular loop of wire is positioned such that a 0.750-T magnetic field is passing through the face of the loop (parallel to the normal to the loop). The loop is physically removed from the field in 0.125 s.
- Initially, what is the magnetic flux through the loop?
 - Once removed from the field, what is the magnetic flux through the loop?
 - What is the average induced emf?
02. The magnetic flux through a loop of wire changes from -15.0 Wb to 32.5 Wb in 0.224 s. What is the induced emf?
03. The magnetic field strength through a 22.4-cm diameter circular coil of wire consisting of 24 turns (loops) changes from 1.450 T to 0.125 T in 0.480 s. The total resistance of the copper wire is 0.0150 Ω .
- What is the induced emf in the coil?
 - What is the induced current flow in the coil?

II

04. A U-shaped conductor consisting of two parallel conducting rails that are connected together by a resistor of $R = 40.0 \Omega$ as shown to the right. A conducting bar, which is $\ell = 18.0$ cm long, is placed across these two rails and a force is applied to this bar so as to move it toward the right with a constant velocity of $v = 12.0$ m/s through a magnetic field of $B = 3.75$ Tesla.
- What will be the EMF generated in this circuit?
 - What will be the magnitude and direction of the resulting electrical current in this circuit?
 - How much force would be required to push this bar along at a constant speed?
 - What will be the strength of the electric field within the moving bar?
 - At what rate is work being done on the moving bar?
05. The same U-shaped conducting apparatus (in the same magnetic field) as problem 04 above has a source of emf with a voltage of 8.00 V inserted in the bottom rail as shown in the diagram to the right. The same conducting bar as problem 04 is placed on the rails, but no outside object applies a force to the conducting bar.
- What is the magnitude and direction of the conventional current in the conducting bar?
 - What force (magnitude and direction) is applied to the bar by the magnetic field?
 - What is the velocity (magnitude and direction) of the bar?

Problem 04

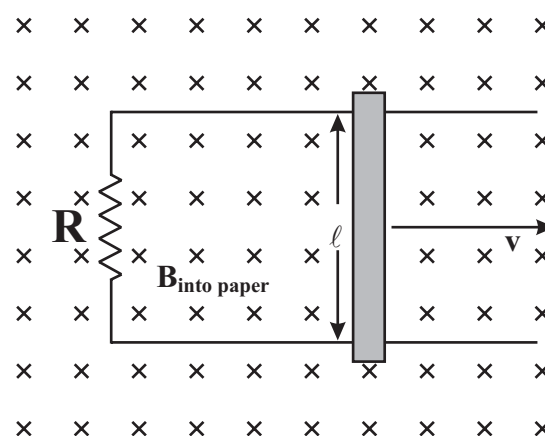

Problem 05

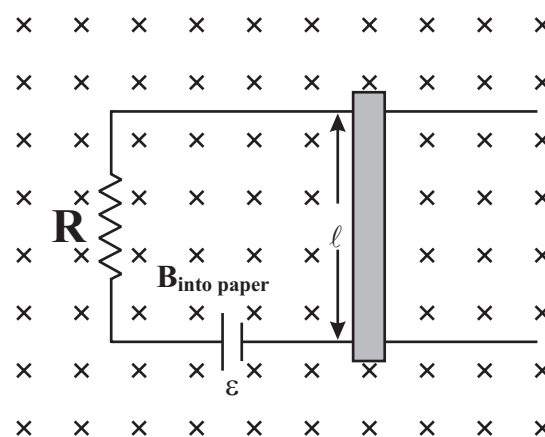

ANSWERS: **01.** a.) 0.0151 Wb b.) 0 Wb c.) 0.121 V **02.** 212 V **03.** a.) 2.61 V b.) 174 A
04. a.) 8.10 V b.) 0.203 A counterclockwise c.) 0.137 N d.) 45 N/C e.) 1.64 W
05. a.) 0.200 A toward the bottom of the page b.) 0.135 N to the right c.) 11.8 m/s to the right

Magnetism & Electromagnetic Induction

Lenz's Law

Homework # 129

I

01. The diagram to the right shows a straight current-carrying wire near a circular loop of wire. Determine the direction of the induced current in the circular loop if the current in the straight wire is directed towards _____ of the page and is _____.
- a.) top, increasing b.) top, decreasing
c.) bottom, increasing d.) bottom, decreasing

Problem 01

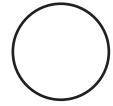

02. In each situation shown below, determine the direction of induced current when viewed from the pole of the magnet that is closest to the loop.

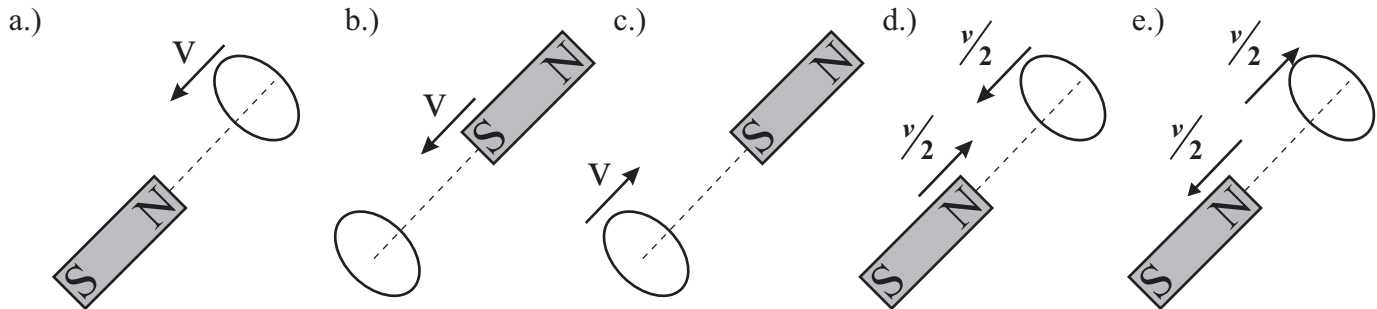

03. A single loop of wire is positioned in the plane of the paper as shown in the diagram to the right. A bar magnet is approaching the loop from above the page leading with the south end of the magnet (i.e. the south end of the magnet is approaching the loop from above the page).
- a.) What is the direction of the induced current in the loop?
b.) What is the direction of the induced current in the loop if the magnet is later pulled in the opposite direction (upward away from the coil)?

Problem 03

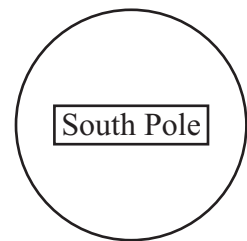

- ### II
04. A coil of wire (solenoid) is connected to an ammeter as shown in the diagram to the right. Initially, a bar magnet is sitting inside the coil oriented as shown. This magnet is then quickly withdrawn to the right.
- a.) What will be the direction of the magnetic field before the magnet is removed from the solenoid?
b.) What will be the direction of the magnetic field **IMMEDIATELY** after the magnet is removed from the solenoid?
c.) What will be the direction of the magnetic field a long period of time after the magnet is removed from the solenoid?
d.) What will be the direction the induced current through the ammeter?
e.) What would be the direction of the induced current through the ammeter if the magnet were withdrawn quickly to the left?

Problem 04

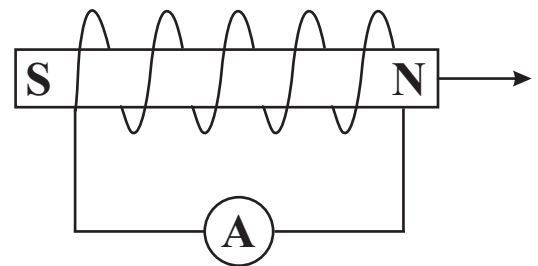

ANSWERS: **01.** a.) counterclockwise b.) clockwise c.) clockwise d.) counterclockwise
02. a.) counterclockwise b.) clockwise c.) clockwise d.) counterclockwise e.) clockwise
03. a.) clockwise b.) counterclockwise
04. a.) right b.) right c.) 0 d.) right e.) right

Magnetism & Electromagnetic Induction

Lenz's Law

Homework # 130

II

05. The diagram to the right shows a rectangular coil of wire sitting in magnetic field directed into the page. A torque is applied to the coil so as to rotate it around the x-axis in a clockwise fashion when view from the right. What is the direction of the induced current during the first $\frac{1}{4}$ of a turn. Even though the coil is rotating, use the current orientation of the coil to describe the direction of the induced current.

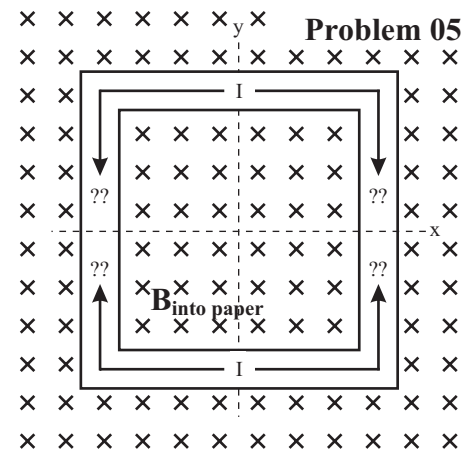

III

06. An electromagnet (solenoid with an iron bar through the center) is wired to a power supply as shown in the diagram to the right. The bar is being pulled to the right away from a loop of wire.
- What is the direction of the current in the wire segment labeled W?
 - What is the direction of the magnetic field within the electromagnet?
 - What is the direction of the induced current in the loop of wire when viewed from the right?

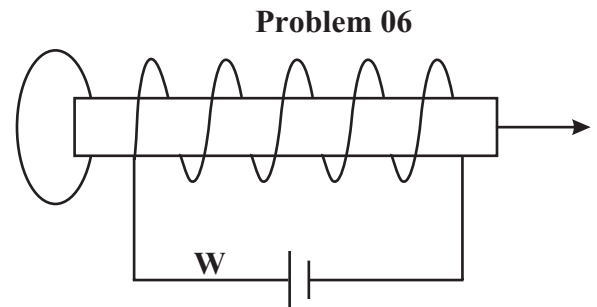

07. Two loops of wire are arranged as shown to the right around a common bar of soft iron. Initially, there is a conventional current I_1 flowing counterclockwise through the left hand loop as shown in the diagram to the right. What will be the resulting effect on the right hand loop if the current in this loop is gradually _____ with time?
- increasing
 - decreasing

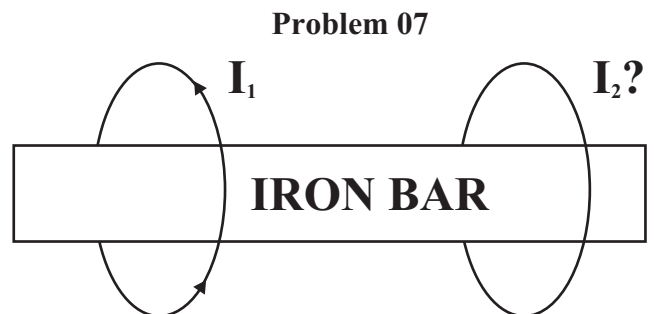

08. Two concentric coils are arranged as shown in the diagram to the right. At $t = 0$ the inner coil has a clockwise current flowing through it. What will be the direction of the induced current in the outside coil if the current in the inner coil is _____ in magnitude as a function of time? [Assume any changes in flux in the small area between the coils are insignificant]
- increasing
 - decreasing

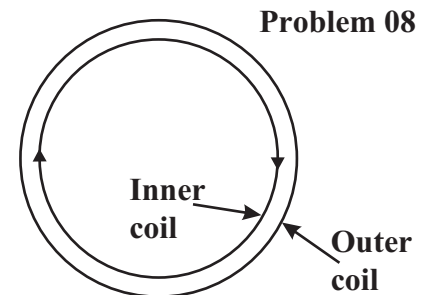

09. What will be the resulting effect on the inner coil in each part of problem 08 above?

ANSWERS: **05.** clockwise **06.** a.) left b.) right c.) counterclockwise
07. a.) move away from left wire b.) move toward left wire
08. a.) counterclockwise b.) clockwise **09.** a.) collapse b.) expand

Magnetism & Electromagnetic Induction

Electric Generators/Counter EMF and Torque

Homework # 131

Electric Generators

I

01. A car generator produces 12.0 V when the armature turns at 725 rev/min. Assuming no other changes what will its output voltage be at 1750 rev/min?
02. A simple generator has square armature windings that are 6.25 cm on a side. There are 145 loops and is positioned in a magnetic field with a strength of 0.589 T. If it rotates at a rate of 105 rev/s, what is the peak output voltage?
03. A simple generator has a 275-loop square coil 27.5 cm on a side. How fast must it turn in a 0.475-T field to produce a 170-V peak output?

II

04. An electric generator produces an rms output voltage of 220 V. The generator has 225 loops on a square armature coil that is 22.5 cm on a side and rotates at 60.0 rev/s. What is the strength of the magnetic field in which the armature is rotating?
05. A circular coil consisting of 245 turns and having a diameter of 6.18 centimeters is rotating in a uniform magnetic field of 4.65 Tesla. At $t = 0.00$ seconds the coil is oriented such that the normal to the plane of the coil is parallel to the direction of the magnetic field and the coil is completing 185 revolutions every second.
- What will be the angular velocity of this rotating coil?
 - What will be the magnetic flux passing through this coil as a function of time?
 - What will be the EMF generated by this coil as a function of time?
 - What will be the EMF 35.0 s after rotations begin?
 - Assuming that this coil has a resistance of 28.0Ω , what will be the resulting average power output of this coil?
 - Assuming that this coil has a resistance of 28.0Ω , what is the maximum torque that must be applied to this coil?

Counter EMF and Counter Torque

I

06. The counter emf of a dc motor wired to a 120-V line reaches 112 V when the motor is running at full speed. If the armature windings of the motor have a resistance of 5.25Ω , what is the current into the motor when the motor is _____?
- starting up
 - running at full speed

II

07. At full speed, a motor draws 4.65 A when connected to a 120 V line. If it has an armature resistance of 4.85Ω , how large is the counter emf?
08. A simple generator has square armature windings that are 5.75 cm on a side. There are 115 loops and is positioned in a magnetic field with a strength of 0.550 T and is rotated at a rate of 137 rev/s. This generator is connected to a load with a resistance of 40.0Ω .
- What is the peak output voltage of this generator?
 - What is the maximum counter torque produced in the generator?

ANSWERS: 01. 30.0 V 02. 220 V 03. 2.74 rev/s 04. 0.0725 T 05. a.) 1162 rad/s
05. b.) $\Phi_B = 3.42 \cos(1162 \cdot t)$ c.) $\varepsilon = 3970 \sin(1162 \cdot t)$ d.) -3460 V e.) $P = (5.63 \times 10^5) \sin^2(1162 \cdot t)$
05. f.) 485 N·m 06. a.) 22.9 A b.) 1.52 A 07. 97.4 V 08. a.) 180 V b.) 0.941 N·m

Magnetism & Electromagnetic Induction

Transformers

Homework # 132

I

01. A transformer, that has 11,200 turns in the secondary, converts 120 V to 21,000 V. Assuming 100 percent efficiency, how many turns must be in the primary?
02. An essentially 100-percent efficient transformer changes 60 V to 220 V.
- What kind of transformer is this?
 - What is the ratio of the current in the secondary to that in the primary?
03. A Neon sign is wired to a 220-V line, but require 12 kV for their operation.
- What is the ratio of secondary to primary turns of the transformer?
 - What would be the voltage to the sign if the transformer would connected backwards?

II

04. A transformer has 1200 primary turns and 225 secondary turns. The input voltage is 120 V and the output current is 7.25 A.
- What type of transformer is this?
 - What is the output voltage?
 - What is the primary current?
05. A 99-percent efficient transformer has 135 turns in the primary and 1400 turns in the primary. If the current in the primary coils is 6.25 A, what is the current in the secondary?
05. A 65.0-kW electric power plant transmits power transmits power over two 0.150Ω lines to a nearby town. The energy conglomerate that owns the power plant saves power by stepping up the voltage from 120 V to 1800 V to transmit it to the town and then steps it back down to 220 V in the town. Both transformers 99 percent efficient.
- What is the current flow in the transmission lines if the power were transmitted at 120 V (not stepped up)?
 - What is the power loss to heat in the transmission lines if the power were transmitted at 120 V (not stepped up)?
 - Including the energy lost in first step-up transformer, what is the current flow in the transmission lines if the power were transmitted at 1800 V.
 - Including the energy losses in both transformers, what is the power loss to heat in the transmission lines if the power were transmitted at 1800 V?
 - How much power is saved by transmitting the power at 1800 V instead of 120 V?

ANSWERS: **01.** 64 **02.** a.) step-up b.) 0.273 **03.** a.) 55 b.) 4.0 V **04.** a.) step-down b.) 22.5 V
04. c.) 1.36 A **05.** 0.597 A **06.** a.) 295 A b.) 26.2 kW c.) 35.8 A d.) 1.68 kW e.) 26.0 kW

Magnetism & Electromagnetic Induction

Magnetism & Electromagnetic Induction Review Homework # 133

II

01. Two very long parallel wires are $R = 1.85$ cm apart and are carrying currents as shown below. The upper wire is carrying a current of $I_1 = 3.50$ A toward the left while the lower wire is carrying a current of $I_2 = 2.50$ A toward the right.

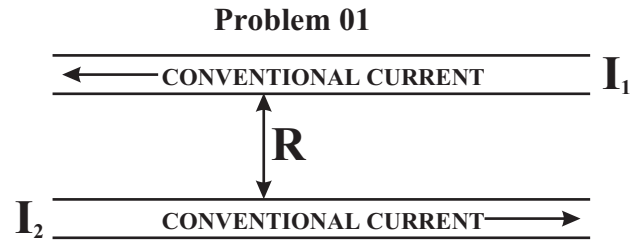

- What is the magnitude and direction of the magnetic field at the location of the upper wire as generated by the lower wire?
- What is the magnitude and direction of the magnetic force acting on 30.0 cm of the upper wire?
- What is the **NET** magnetic field (magnitude and direction) at a point exactly midway between these two wires?
- What is the magnitude and direction of the magnetic field 1.25 cm above the upper wire?
- What is the magnitude and direction of the magnetic force acting on 30.0 cm of the upper wire if the current flowing through the lower wire is reversed? Explain!

02. The diagram to the right shows two parallel conducting rails that are connected together by a resistor of $R = 105.0 \Omega$. A conducting bar, which has a length of $\ell = 14.0$ cm long, is placed across these two rails and a force is applied to this bar so as to move it toward the right with a constant velocity of $v = 11.5$ m/s through a magnetic field of $B = 1.95$ T.

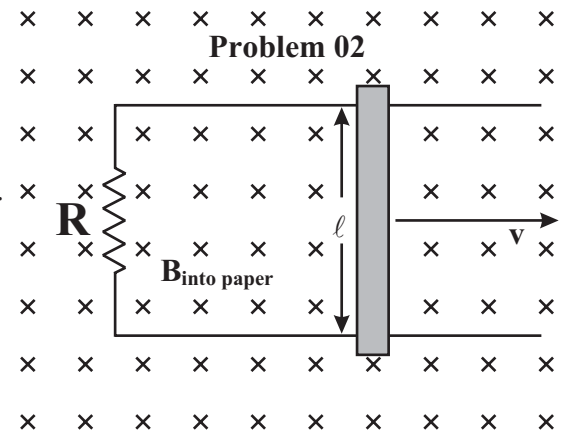

- What will be the EMF generated in this circuit?
- What will be the magnitude and direction of the resulting electrical current in this circuit?
- How much force would be required to push this bar along at a constant speed?
- What will be the strength of the electric field within the moving bar?
- At what rate is work being done on the moving bar?

03. A particle, which has a charge of $q = -14.5 \mu\text{C}$ and a mass of 3.45×10^{-12} kg, enters a magnetic field of $B = 960$ Gauss, as shown to the right, with a velocity of 5400 m/s perpendicular to the direction of the magnetic field.

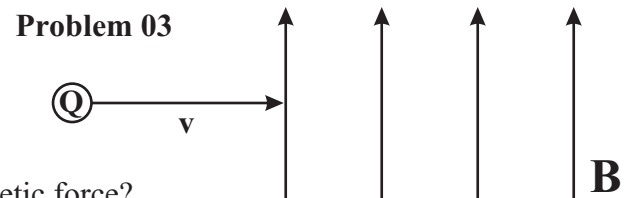

- What will be the magnitude and direction of the resulting magnetic force?
- Describe, exactly, the path that this particle will follow as it moves through the magnetic field and determine the magnitude of the parameter which describes this path?
- What will be the direction and magnitude of an electric field which can be added to this magnetic field so that this charge passes through both fields undeflected?
- Suppose that instead of entering this magnetic field at a right angle, the particle enters at an angle of 56.0° relative to the magnetic field from the bottom of the page. What will be the magnitude of the resulting magnetic force? Assume the electric field added in part C is **NOT** present.
- Describe, exactly, the path that this particle from part D will now follow as it moves through the magnetic field and determine the magnitude of the two parameters [radius and pitch] which describe this path?

ANSWERS: **01.** a.) 2.70×10^{-5} T out of page b.) 2.84×10^{-5} N toward top of page c.) 1.30×10^{-4} T out of page
01. d.) 3.99×10^{-5} T into the page e.) 2.84×10^{-5} N toward bottom of page **02.** a.) 3.14 V
02. b.) 0.0299 counterclockwise c.) 8.16×10^{-3} N d.) 22.4 N/C e.) 0.0939 W **03.** a.) 7.52×10^{-3} N into page
03. b.) counterclockwise circular path when viewed from above ($r = 1.34$ cm) c.) 502 N/C into page
03. d.) 6.23×10^{-3} N e.) counterclockwise spiral (view from above) toward top of page ($r = 1.11$ cm, $p = 4.70$ cm)

Magnetism & Electromagnetic Induction

Magnetism & Electromagnetic Induction Review Homework # 134

II

04. A circular coil of conducting wire with a diameter of 0.300 m consists of 250 turns and is rotating at 75.0 rpm in the presence of a 1.35 T magnetic field. The coil has a total resistance of 30.0 Ω . The area of the loop is parallel to the field at time $t = 0.00$ s.
- What is the angular velocity of this rotating coil?
 - Describe the magnetic flux as a function of time.
 - What is the maximum flux that will pass through this coil?
 - How long will it take to achieve this maximum flux the first time?
 - What is the minimum flux that will pass through this coil?
 - How long will it take to achieve this minimum flux the first time?
 - What will be the flux after 1.32 seconds?
 - Describe the induced EMF as a function of time.
 - What is the maximum induced EMF that will be created in this coil?
 - How long will it take to achieve this maximum EMF the first time?
 - What is the minimum induced EMF that will be created in this coil?
 - How long will it take to achieve this minimum EMF the first time?
 - What will be the EMF after 1.32 seconds?
 - What will be the current flow as a function of time?
 - What is the maximum current flow in this coil?
 - How long will it take to achieve this maximum current the first time?
 - What is the minimum current flow in this coil?
 - How long will it take to achieve this minimum current the first time?
 - What will be the current after 1.32 seconds?
 - Describe the power consumed as a function of time.
 - What will be the maximum power consumption for any instant?
 - What will be the minimum power consumption for any instant?
 - What is the average power consumed?
 - Describe the external torque as a function of time that would be required to maintain this **CONSTANT** angular velocity.
 - What would be the maximum torque required to maintain this angular velocity?
 - What would be the minimum torque required to maintain this angular velocity?

ANSWERS: **04.** a.) 7.85 rad/s b.) $\Phi_B = 23.86 \cos(7.85 \cdot t)$ c.) 23.86 Wb d.) 0 s, 0.400 s e.) 0 Wb
04. f.) 0.200 s g.) -14.1 Wb h.) $\varepsilon = 187.3 \sin(7.85 \cdot t)$ i.) 187.3 V j.) 0.200 s k.) 0 V l.) 0.400 s
04. m.) -150.9 V n.) $I = 6.24 \sin(7.85 \cdot t)$ o.) 6.24 A p.) 0.200 s q.) 0 A r.) 0.400 s s.) -5.03 A
04. t.) $P = 1168 \sin^2(7.85 \cdot t)$ u.) 1168 W v.) 0 W w.) 584 W x.) $\tau = 149 \sin(7.85 \cdot t)$
04. y.) 149 N·m z.) 0 N·m

Engineering Magnetism: Magnetic Field Calculations & Inductors

The Biot-Savart Law (Magnetic Field Strength of Currents) Homework # 135

II

01. A short conducting wire is connected to a positive terminal on the left and a negative terminal on the right causing a current of I to flow to the right in the wire as shown in the diagram to the right. Point P_1 is on the perpendicular bisector of the wire, while point P_2 is directly above the right end of the wire. ($x = \frac{L}{2}$)

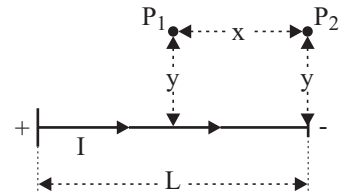

Problem 01

- What is magnitude (in terms of I , y , x , and any constants) and direction of the magnetic field at point P_1 ?
- If $I = 12.0$ A, $y = 9.00$ cm and $L = 14.00$ cm, what is the strength of the magnetic field at P_1 ?
- If $I = 12.0$ A, $y = 9.00$ cm and $L = 14.00$ cm, what is the strength of the magnetic field at P_2 ?
- What is magnitude (in terms of I , y , x , and any constants) and direction of the magnetic field at point P_1 if $L \gg y$?
- If $I = 12.0$ A, $y = 9.00$ cm and $L = 14.00$ m, what is the strength of the magnetic field at P_1 ?

02. The diagram to the right shows a circular conducting loop with a current of I created by a changing magnetic field. The direction of the current, I , is counterclockwise when viewed from the right as shown by the blue arrows. The origin of the coordinate system, O , is at the center of the loop with the x -axis as the perpendicular bisector of the face of the loop. The distance between points O and P is x .

Problem 02

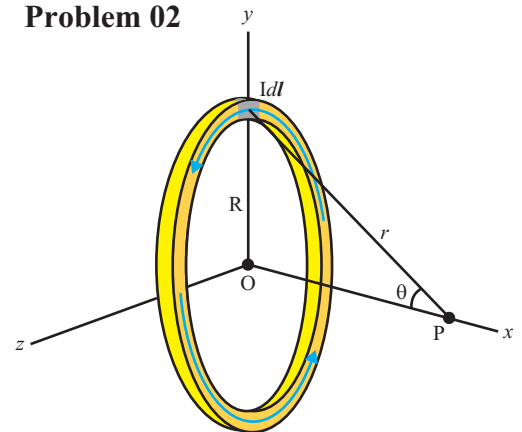

- What is the magnitude (in terms of I , R , and any constants) and direction of the magnetic field at point O ?
- If $I = 7.00$ A and $R = 4.00$ cm, what is the strength of the magnetic field at O ?
- What is the magnitude (in terms of I , R , x , and any constants) and direction of the magnetic field at point P ?
- If $I = 7.00$ A, $R = 4.00$ cm, and $x = 7.50$ cm, what is the strength of the magnetic field at P ?

03. A conducting wire is shaped as shown in the diagram to the right. The straight segments of the wire have a length of 6.00 cm each while the center portion is a semicircle with a radius of 8.00 cm. The current in the wire is in the direction shown and has a magnitude of 9.00 A. What is the magnitude and direction of the magnetic field created by this current-carrying wire at point P ?

Problem 03

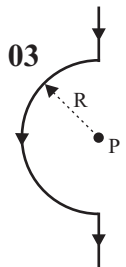

04. A conducting wire is shaped as shown in the diagram to the right. The current in the wire is in the direction shown and has a magnitude of 6.00 A. Wire segments A and D each have a length of 10.00 cm each. The two vertical segments (one of which is labeled y) each have a length of 8.00 cm each, while the segment labeled x has a length of 16.00 cm. What is the magnitude and direction of the magnetic field created by this current-carrying wire at point P ?

Problem 04

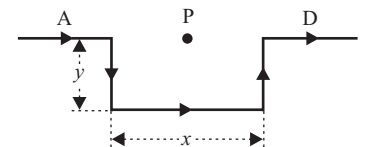

ANSWERS: 01. a.) $\frac{\mu_0 I}{2\pi y} \frac{x}{\sqrt{x^2 + y^2}}$ (out of page) b.) 1.64×10^{-5} T c.) 1.12×10^{-5} T d.) $\frac{\mu_0 I}{2\pi y}$ (out of page)

01. e.) 2.67×10^{-5} T 02. a.) $\frac{\mu_0 I}{2R}$ (out of page) b.) 1.10×10^{-4} T c.) $\frac{\mu_0}{2} \frac{IR^2}{(x^2 + R^2)^{3/2}}$ d.) 1.15×10^{-5} T

03. 3.53×10^{-5} T (out of page) 04. 3.00×10^{-5} T (out of page)

Engineering Magnetism: Magnetic Field Calculations & Inductors

Ampere's Law (Magnetic Field Strength of Currents) Homework #136

- I**
01. A current of 6.35 A is flowing through to the left in a long straight conducting wire as shown in the diagram to the right. If point P is located a distance of 3.85 cm from the wire, determine the magnitude and direction of the magnetic field at point P.

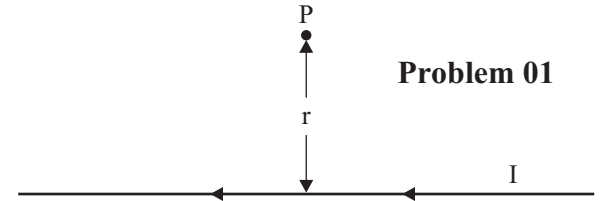

Problem 01

- II**
02. A solenoid, shown in the diagram to the right, has a length $L = 17.5$ cm, a diameter of $d = 2.30$ cm, and $N = 630$ turns (assume the windings of the solenoid are wrapped much tighter than depicted in the diagram such that the space between coils is very small). A current of $I = 4.75$ A is flowing through the solenoid. The rectangle MNOP is chosen as the closed path for Ampere's law. Segments P and N of the rectangle have a length of l , while segments M and O have a width w .

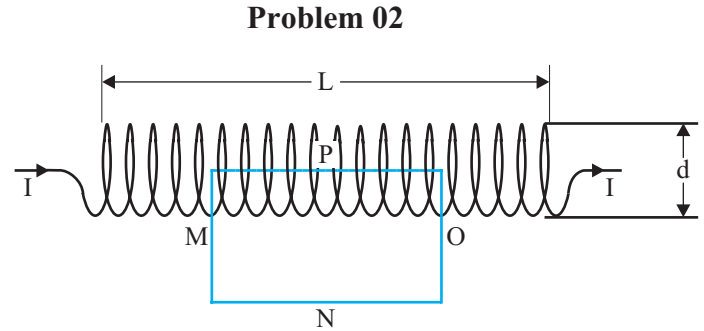

Problem 02

- What is the number of turns per unit length, n ?
- What is the result of the integration of Ampere's law to segment M of the rectangular closed path?
- What is the result of the integration of Ampere's law to segment N of the rectangular closed path?
- What is the result of the integration of Ampere's law to segment O of the rectangular closed path?
- What is the result of the integration of Ampere's law to segment P of the rectangular closed path?
- What is the **TOTAL** current enclosed by rectangle MNOP?
- What is the magnetic field strength, B , within the solenoid?

03. Two long parallel wires are shown in the diagram to the right. The current in the top wire is $I_1 = 4.00$ A to the left, while the current in the bottom wire is $I_2 = 5.50$ A to the left. Point P is positioned such that $r_1 = 7.00$ cm from the top wire, while $r_2 = 3.00$ cm from the bottom wire. What is the magnitude and direction of the net magnetic field at point P?

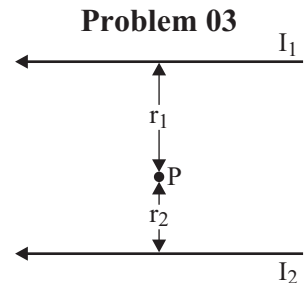

Problem 03

Problems 04 and 05 below refer to the diagram to the right and below which shows a wire with a diameter of 1.500 cm and a current of $I_{in} = 1.75$ A directed into the page. Point P_1 is a distance of $r_1 = 4.500$ cm from the center of the wire, while point P_2 is a distance of $r_2 = 0.500$ cm from the center.

04. The wire has a uniform current density, J .
- What is the magnitude of the current density, J , within the wire?
 - What is the magnitude and direction of the magnetic field at point P_1 ?
 - What is the magnitude and direction of the magnetic field at point P_2 ?

Problems 04 & 05

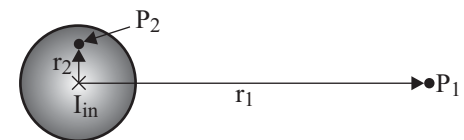

- III**
05. The current density within the wire varies with distance from the center, r , according to the relationship $J = (9400 + 100,595r)$ A/m².
- What is the total current $I_{enclosed}$ within an appropriate Ampere's law closed path to determine the B_{net} at point P_2 ?
 - What is the strength of the magnetic field, B_{net} , at point P_2 ?

ANSWERS: 01. 3.30×10^{-5} T 02. a.) 3600 turns/m b.) 0 c.) 0 d.) 0 e.) $B \cdot l$ f.) $n \cdot I \cdot l$ g.) 0.0107 T
 03. 2.52×10^{-5} T 04. a.) 9900 A/m² b.) 7.78×10^{-6} T toward bottom of page c.) 3.11×10^{-4} T to the right
 05. a.) 0.765 A b.) 3.06×10^{-5} T

Engineering Magnetism: Magnetic Field Calculations & Inductors

Faraday's Law & Induced Emf

Homework #137

I

01. A 60-turn coil has a radius of 4.0 cm and a resistance of 15.0 Ω . What is the rate at which a magnetic field perpendicular to the face must change to produce a current of 2.50 A?
02. The flux through a loop is given by $\phi_m = (0.100 \text{ Tm}^2) \cdot (3t^2 - 8t)$, where t is in seconds.
- What is ϕ_m at $t = 0.00$ s?
 - What is ϕ_m at $t = 2.00$ s?
 - What is ϕ_m at $t = 4.00$ s?
 - What is ϕ_m at $t = 6.00$ s?
 - Write the expression for the emf, ε , as a function of time.
 - What is ε at $t = 0.00$ s?
 - What is ε at $t = 2.00$ s?
 - What is ε at $t = 4.00$ s?
 - What is ε at $t = 6.00$ s?

II

03. A magnetic field \mathbf{B} is perpendicular to the plane of the page and uniform in a circular region of radius R as shown in the diagram to the right. Outside the circular region, $\mathbf{B} = 0$. The magnitude of \mathbf{B} is increasing at the rate of $d\mathbf{B}/dt$.
- Write an equation that describes the magnitude of the electric field, E , as a function of distance, r , from the center, where $r < R$.
 - Describe the direction of the electric field at all points a given distance, r , from the center, where $r < R$.
 - If the magnetic field strength is increasing at a rate of 0.250 T/s and $R = 12.00$ cm, what is E at 9.00 cm?
 - Write an equation that describes the magnitude of the electric field, E , as a function of distance, r , from the center, where $r > R$.
 - If the magnetic field strength is increasing at a rate of 0.250 T/s and $R = 12.00$ cm, what is E at 25.00 cm?

Problem 03

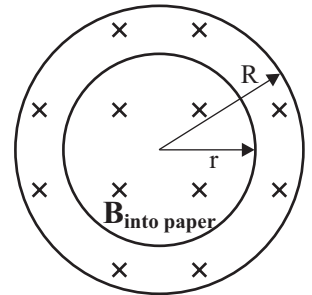

04. A flip coil is a small coil that is rotated in a magnetic field and is used to measure the strength of the magnetic field. The field strength is determined by connecting the flip coil to a device known as a current integrator, $\text{\textcircled{C}}$, which measures the amount of charge that passes through the coil as a result of the induced emf and current produced by the changing magnetic flux through the coil as it rotates. One such circular flip coil of N turns and resistance, R , is shown in the diagram to the right. The coil has its face in the plane of the page and perpendicular to a uniform magnetic field \mathbf{B} which is into the plane of the page. Find the charge passing through the coil if the coil is rotated 180° about its diameter.

Problem 04

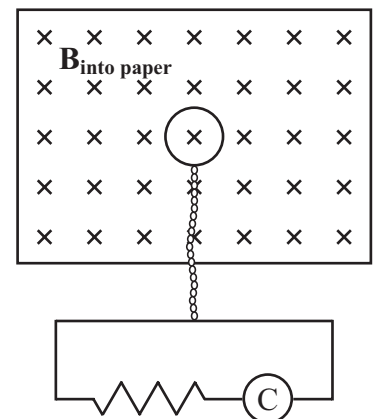

ANSWERS: 01. 124 T/s 02. a.) 0 Tm² b.) -0.400 Tm² c.) 1.60 Tm² d.) 6.00 Tm²

02. e.) $\varepsilon = (0.100 \text{ V}) \cdot (6t - 8)$ f.) -0.800 V g.) 0.400 V h.) 1.60 V i.) 2.80 V

03. a.) $\varepsilon = \frac{r}{2} \frac{dB}{dt}$ b.) Tangent to a counterclockwise circle c.) 11.3 mV d.) $\varepsilon = \frac{R^2}{2r} \frac{dB}{dt}$ e.) 7.20 mV

04. $Q = \frac{2NBA}{R}$

Engineering Magnetism: Magnetic Field Calculations & Inductors

Inductors & Magnetic Field Energy Storage

Homework # 138

I

01. What is the induced emf in a 385-mH coil if the current varies from 15.0 mA to 40.0 mA in 425 ms?
02. An emf of 9.25 V is produced in a coil when its current changes from -42.0 mA to +57.0 mA in 37.4 ms. What is its inductance, L ?
03. An air-filled coil that is 32.0 cm long is 2.48 cm in diameter and contains 7500 loops. What is its inductance, L ?
04. A coil that is 12.5 cm long and has a diameter of 3.70 cm has an inductance of 1.95 mH when filled with air.
 - a.) How many turns does are in this inductor?
 - b.) How much energy is stored in this inductor when the current is 7.25 A?
 - c.) If an iron core with a $\mu = 3 \times 10^3 \mu_0$ is placed inside the coil, what would be the inductance?
 - d.) How much energy is stored in the inductor in part c.) above when the current is 7.25 A?
05. How much energy is stored in a 70.0 mH inductor at an instant when the current is 4.50 A?
06. A solenoid is 18.5 cm long and has a diameter of 2.30 cm. The magnetic field inside this solenoid is 0.775 T. Approximately how much energy is stored in this field?

II

07. A current rises sharply from 0 to I in 3.75 ms inducing a 60-V emf in a 0.225 H inductor. What is the value of I ?
08. The earth's magnetic field strength near its surface varies around the earth but averages about 0.50 G ($1 \text{ G} = 10^{-4} \text{ T}$).
 - a.) Estimate the average energy density of this field near the earth's surface.
 - b.) Estimate the total energy stored in this field in the first 5.0 km above the earth's surface.
09. In a laboratory, an electric field of $3.0 \times 10^3 \text{ V/m}$ and a magnetic field of 1.5 T are produced.
 - a.) What is the energy density for the electric field?
 - b.) What is the energy density for the magnetic field?
 - c.) What electric field strength would be needed to produce the same energy density as the 1.5 T magnetic field?

10. Two concentric solenoids are shown in the diagram to the right. Solenoid 1 has N_1 turns on an iron core ($\mu = 6000\mu_0$), a radius of r_1 , and an initial current of I_1 flowing through it in a counterclockwise direction when viewed from the right as shown. The current drops to 0 in time t . Solenoid 2, the larger solenoid shown with blue wire in the diagram, has N_2 turns and a radius of r_2 . Both solenoids have a length of l .

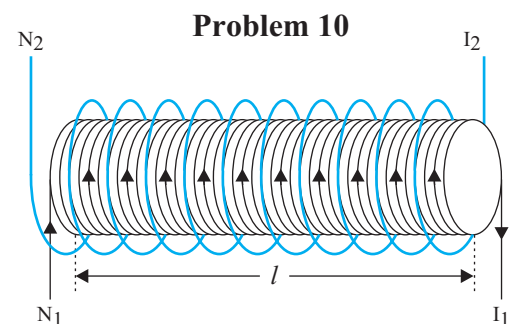

- a.) What is the mutual inductance?
- b.) What is the mutual inductance if $N_1 = 600$ turns, $r_1 = 1.50 \text{ cm}$, $I_1 = 3.00 \text{ A}$, $t = 15.0 \text{ ms}$, $N_2 = 150$ turns, $r_2 = 2.00 \text{ cm}$, and $l = 32.0 \text{ cm}$?
- c.) For the solenoids described in part b.) above, what is the induced emf in Solenoid 2? (What is its direction?)

ANSWERS: **01.** 0.0226 V **02.** 353 H **03.** 0.107 H **04.** a.) 425 turns b.) 0.0512 J c.) 5.85 H d.) 154 J

05. 0.709 J **06.** 18.4 J **07.** 1.00 A **08.** a.) $9.95 \times 10^{-4} \text{ J/m}^3$ b.) $2.54 \times 10^{15} \text{ J}$

09. a.) $3.98 \times 10^{-5} \text{ J/m}^3$ b.) $8.95 \times 10^5 \text{ J/m}^3$ c.) $4.50 \times 10^8 \text{ V/m}$ [$B_c = (1.5 \text{ T}) c$]

10. a.) $M_{12} = \mu \left(\frac{N_1 N_2}{l} \right) \pi r_1^2 = 6000\mu_0 \left(\frac{N_1 N_2}{l} \right) \pi r_1^2$ b.) 0.375 H c.) 74.9 V (CCW when viewed from right)

Engineering Magnetism: Magnetic Field Calculations & Inductors

LR Circuits (DC Power Source)

Homework # 139

I

01. A circuit is constructed as shown in the diagram to the right. The voltage of the battery is $V = 18.0 \text{ V}$, the resistor has a resistance of $R = 27.0 \Omega$, and the inductor has a reactance of 0.475 H . The switch has been open for a long time, but closes as a clock starts at $t = 0 \text{ s}$.

- What is the initial current, I_0 , of the circuit at $t = 0 \text{ s}$? Explain!!!
- What is the time constant for this circuit?
- What will the current be a long time after the switch is closed?
- Write an equation that predicts the current as a function of time for this circuit.
- What will the current be at $t = 15.0 \text{ ms}$?
- What will the current be at $t = 15.0 \text{ s}$?
- Sketch a graph of the current as a function of time.

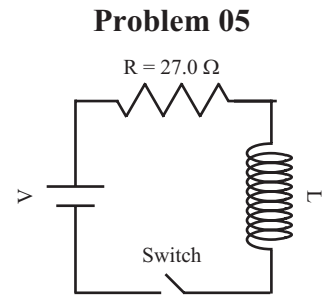

02. A circuit is constructed as shown in the diagram to the right. The voltage of the battery is $V = 1.50 \text{ V}$, the resistor has a resistance of $R = 3.75 \Omega$, and the inductor has a reactance of 25.0 mH . The switch has been closed for a long time so that a steady current was flowing in the circuit, but the switch opens as a clock starts at $t = 0 \text{ s}$.

- What is the initial current, I_0 , of the circuit at $t = 0 \text{ s}$? Explain!!!
- What is the time constant for this circuit?
- What will the current be a long time after the switch is opened?
- Write an equation that predicts the current as a function of time for this circuit.
- What will the current be at $t = 15.0 \text{ ms}$?
- What will the current be at $t = 15.0 \text{ s}$?
- Sketch a graph of the current as a function of time.

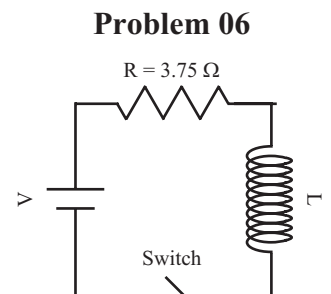

03. A circuit is constructed as shown in the diagram to the right. The voltage of the battery is $V = 40.0 \text{ V}$, the two resistors have a resistances of $R_1 = 33.60 \Omega$ and $R_2 = 4.40 \Omega$, and the inductor has a reactance of 9.55 H . Both switches have been open for a long time, but switch S_1 closes as a clock starts at $t = 0 \text{ s}$, while switch S_2 remains open.

- What is the initial current, I_0 , of the circuit at $t = 0 \text{ s}$? Explain!!!
- What is the time constant for this circuit?
- What will the current be a long time after the switch is closed?
- Write an equation that predicts the current as a function of time for this circuit.
- What will the current be at $t = 15.0 \text{ ms}$?
- Sketch a graph of the current as a function of time.

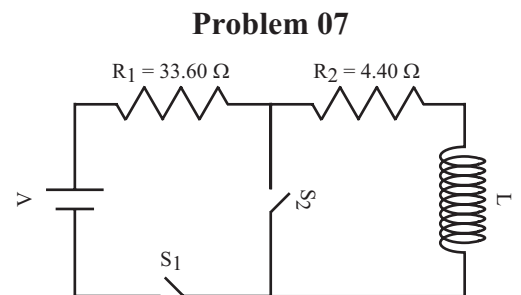

After a long time, S_1 opens as S_2 simultaneously closes, and a new clock starts ($t = 0 \text{ s}$) at this instant.

- What is the initial current, I_0 , of the circuit at $t = 0 \text{ s}$? Explain!!!
- What is the time constant for this circuit?
- Write an equation that predicts the current as a function of time for this circuit.
- At what time does the current drop to 10% of I_0 ?
- At what time does the current drop to 1% of I_0 ?
- At what time does the current drop to 0.1% of I_0 ?
- Sketch a graph of the current as a function of time.

ANSWERS: 01. a.) 0 A b.) 17.6 ms c.) 0.667 A d.) $I = (0.667 \text{ A})(1 - e^{-\frac{t}{0.0176}})$ e.) 0.383 A f.) 0 A

02. a.) 0.400 A b.) 6.67 ms c.) 0 A d.) $I = (0.400 \text{ A})e^{-\frac{t}{0.00667}}$ e.) 0.0422 A f.) 0 A

03. a.) 0 A b.) 251 ms c.) 1.05 A d.) $I = (1.05 \text{ A})(1 - e^{-\frac{t}{0.251}})$ e.) 0.0608 A

03. g.) 9.09 A h.) 2.17 s i.) $I = (9.09 \text{ A})e^{-\frac{t}{2.17}}$ j.) 5.00 s k.) 10.0 s l.) 15.0 s

Engineering Electric Circuits: AC Electric Circuits

Alternating Current in a Resistor

Homework # 140

This is a copy of Homework #113 titled "Alternating Current" in the chapter titled "DC Electric Circuits".

I

01. An ac voltage supply with a peak voltage of 180 V is applied across a 480- Ω resistor.
a.) What is the value of the peak current in the resistor?
b.) What is the value of the rms current in the resistor?
02. What is the peak current in a 2.80-k Ω resistor connected to a 240-V ac power source?
03. Determine the resistance of the following 120-V_{rms} light bulbs.
a.) 40.0 W b.) 60.0 W c.) 75.0 W d.) 100 W

II

04. What is the peak current passing through a 100-W light bulb connected to a 120-V ac line?
05. If the peak value of alternating current passing through a 1250-W electric device is 4.25 A, what is the rms voltage across it?
06. What is the maximum instantaneous value of the power dissipated by a 75.0-W light bulb?
07. A 15.0- Ω heater coil is connected to a 240-V ac line.
a.) What is the average power used by this coil?
b.) What is the maximum value of the instantaneous power?
c.) What is the minimum value of the instantaneous power?

ANSWERS: **01.** a.) 0.530 A b.) 0.375 A **02.** 0.121 A **03.** a.) 360 Ω b.) 240 Ω c.) 192 Ω d.) 144 Ω
04. 1.18 A **05.** 416 V **06.** 150 W **07.** a.) 3840 W b.) 7680 W c.) 0 W

Engineering Electric Circuits: AC Electric Circuits

Alternating Current in Inductors and Capacitors

Homework # 141

I

01. At what frequency will a _____?
 - a.) 97.5- μ F capacitor have a reactance of 35.0 Ω
 - b.) 626-mH inductor have a reactance of 1.85 k Ω ?
02. On the coordinate axes to the right, sketch a graph of impedance of a 10.0- μ F capacitor as a function of frequency from 10.0 to 1000.0 Hz. What is Z_{\max} for this range?
03. On the coordinate axes to the right and below, sketch a graph of impedance of a 10.0-mH inductor as a function of frequency from 10.0 to 1000.0 Hz. What is Z_{\max} for this range?

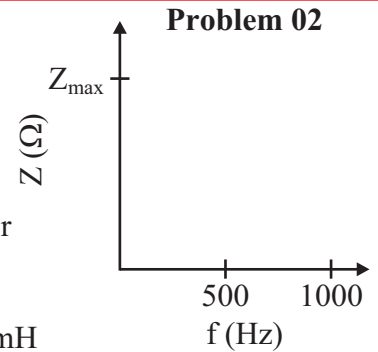

II

04. At what frequency would the reactance of a 10.0-mH inductor equal that of a 100.0- μ F capacitor?
05. A coil draws 22.5 A of current from a 120-V ac power supply operating at 60.0 Hz. What is the inductance of this coil?
06. A capacitor draws 22.5 A of current from a 120-V ac power supply operating at 60.0 Hz. What is the inductance of this capacitor?
07. For each of the following circuits, use the coordinate axes below to construct the graph indicated.
 - a.) A 35.0-mH inductor is wired to a 120-V ac power supply operating at 60.0 Hz. Find I_{\max} and graph I vs t.
 - b.) A 35.0-mH inductor draws 7.50 A from an ac power supply operating at 60.0 Hz. Find V_{\max} and graph V vs t.
 - c.) A 35.0- μ F capacitor is wired to a 120-V ac power supply operating at 60.0 Hz. Find I_{\max} and graph I vs t.
 - d.) A 35.0- μ F capacitor draws 7.50 A from an ac power supply operating at 60.0 Hz. Find V_{\max} and graph V vs t.

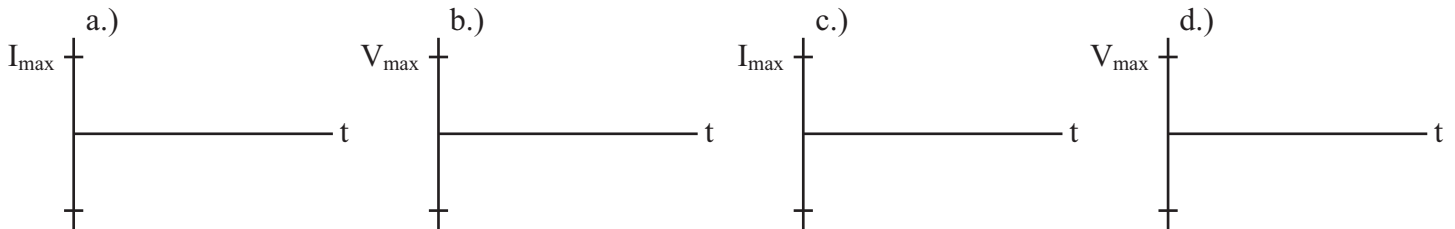
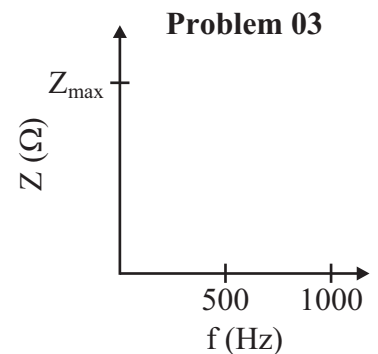

08. The diagrams below show two possible arrangements, I and II, for two circuits, A and B, and a capacitor. In both arrangements assume the capacitance of the capacitor is very large.
 - a.) Which arrangement will allow an ac signal but not a dc signal from circuit A to B? Explain!!!
 - b.) Which arrangement will allow a dc signal but not an ac signal from circuit A to B? Explain!!!

Problem 08

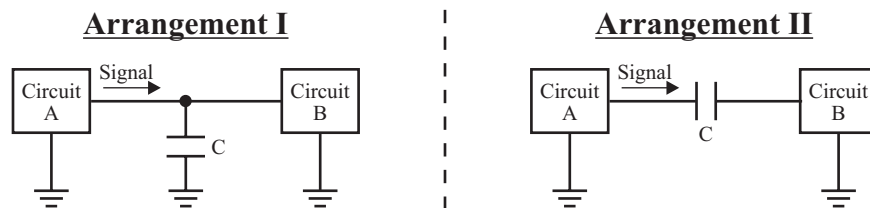

ANSWERS: 01. a.) 46.6 Hz b.) 470 Hz 02. 1592 Ω 03. 62.8 Ω 04. 159 Hz 05. 5.33 H 06. 5.33 H
 07. a.) 9.09 A b.) 99.0 V c.) 1.58 A d.) 568 V 08. a.) Arrangement II b.) Arrangement I

Engineering Electric Circuits: AC Electric Circuits

Phasors/LC & LRC Circuits Without a Generator Homework # 142

I

01. An LRC circuit is designed such that $V_L > V_C$.
- Draw the resultant phasor diagram.
 - Draw the phase angle, δ , and indicated whether the emf of the circuit leads or lags the current by δ .
 - Describe how the phase angle, δ , can be calculated from V_R , V_L , and V_C .
02. An LRC circuit is designed such that $V_L < V_C$.
- Draw the resultant phasor diagram.
 - Draw the phase angle, δ , and indicated whether the emf of the circuit leads or lags the current by δ .
 - Describe how the phase angle, δ , can be calculated from V_R , V_L , and V_C .
03. What is the period of oscillation of an LC circuit consisting of a 15.0-mH coil and a 150.0- μ F capacitor?
04. An LC circuit, with a 65.0- μ F capacitor, oscillates at a 60.0-Hz frequency. What is the inductance of the inductor?
05. Circuit 1 is an LC circuit that has an inductance of L_1 and a capacitance of C_1 . Circuit 2, a second LC circuit, has an inductance of $L_2 = \frac{1}{2}L_1$ and a capacitance of $C_2 = 2C_1$, while a circuit 3, a third LC circuit, has an inductance of $L_3 = 2L_1$ and a capacitance of $C_3 = \frac{1}{2}C_1$.
- Which circuit oscillates at the greatest frequency?
 - Which circuit oscillates at the least frequency?
 - If all capacitors are charged to the same voltage, which circuit would have the greatest I_{\max} ?
 - If all three circuits have the same I_{\max} , which circuit will have the inductor that has the greatest voltage?

II

06. A 25.0- μ F capacitor is charged to 60.0 V and then connected to a 40.0-mH inductor. The two plates of the capacitor are separated by 2.00 mm of air and each plate has an area of 0.600 m². The length of the inductor is 10.00 cm and the coils have a radius of 1.00 cm.
- What is the total charge stored on the capacitor before it is connected to the inductor?
 - How much electric energy is stored in the capacitor before it is connected to the inductor?
 - What is the electric energy density of the capacitor before it is connected to the inductor?
 - What is the electric field strength in the capacitor before it is connected to the inductor?
 - What is the maximum magnetic energy stored in the inductor after its connection to the capacitor?
 - What is the maximum magnetic energy density of the inductor after its connection to the capacitor?
 - What is the maximum magnetic field strength in the inductor after its connection to the capacitor?
 - What is the frequency of oscillation in the circuit?
 - What is the maximum current in the circuit?
 - Write an equation that describes the charge on the capacitor as a function of time in this circuit and graph Q vs t.
 - Write an equation that describes the current in this circuit as a function of time and graph I vs t.
 - Graph Q and I as a function of time on the coordinate axes below and to the right if a small resistor is included in series in the circuit (such as the resistance of the wire that is coiled to make the inductor).

ANSWERS: **01.** b.) ϵ leads I c.) $\tan \delta = \frac{V_L - V_C}{V_R}$ **02.** b.) ϵ lags I c.) $\tan \delta = \frac{V_C - V_L}{V_R}$ **03.** 9.42 ms

04. 9.24 H **05.** a.) none (all equal) b.) none (all equal) c.) circuit 2 d.) circuit 3

06. a.) 1.50 mC b.) 45.0 mJ c.) 3.75 J/m³ d.) 9.21 x 10⁵ V/m e.) 45.0 mJ f.) 1430 J/m³ g.) 0.0600 T

06. h.) 159 Hz ($\omega = 1000$ rad/s) i.) 1.50 A j.) $Q = (0.00150)\cos(1000t)$ k.) $I = -(1.50)\sin(1000t)$

Engineering Electric Circuits: AC Electric Circuits

LRC Circuits With a Generator/Resonance

Homework # 143

I

01. An AC generator that has a maximum emf of 30.0 V and an angular frequency of 300.0 rad/s is connected in series with a 34.8- μF capacitor and a 95.0- Ω resistor.
- What is the impedance?
 - What is the power factor?
 - What is the rms current?
 - What is the average power supplied?
02. A coil can be treated as a resistance in series with an inductor. A coil with a resistance of 80.0 Ω and an inductance of 0.350 H is connected to a 120-V line with a frequency of 60.0 Hz.
- What is the impedance?
 - What is the power factor?
 - What is the rms current?
 - What is the average power supplied?
03. A series LCR consists of a 50.0-mH inductor, a 50.0- μF capacitor and a 50.0- Ω resistor driven by a 50.0-V generator with a variable resistor, ω .
- What is the resonant angular frequency ω_0 ?
 - Find X_L , X_C , Z , I_{rms} , the phase angle, δ , and the power factor at ω_0 .
 - Find X_L , X_C , Z , I_{rms} , the phase angle, δ , and the power factor when $\omega = 3000$ rad/s.
04. FM radio stations are assigned carrier waves by the FCC in the range of 88.0 to 108.0 MHz. A radio receiver is a series LCR circuit with a variable capacitor so that it can resonate with any carrier wave frequency in this range. A particular radio has a 1.50- μH inductor.
- What is the range of capacitances necessary to cover this range of frequencies?
- For parts b.) through d.), assume the radio is tuned to 104.6 MHz and $\Delta f = 0.05$ MHz.**
- What is the capacitance?
 - What is the Q factor?

II

05. On the graphs above and to the right sketch a graph of Z versus ω for a series _____ circuit.
- LR
 - RC
 - LRC
06. In the circuit shown to the right, the variable frequency ac generator produces an rms voltage of 120 V when operated at 60.0 Hz. Assume transient effects have had sufficient time to decay so steady state conditions exist.
- What is the rms current in the circuit?
 - Find the rms voltage across AB.
 - Find the rms voltage across BC.
 - Find the rms voltage across CD.
 - Find the rms voltage across AC.
 - Find the rms voltage across BD.
 - What is the maximum energy stored in the capacitor?
 - What is the maximum energy stored in the inductor?
 - What is the resonant angular frequency of this circuit?
 - What is the average power supplied to the circuit by the generator?
 - What is the average power consumed by the resistor?

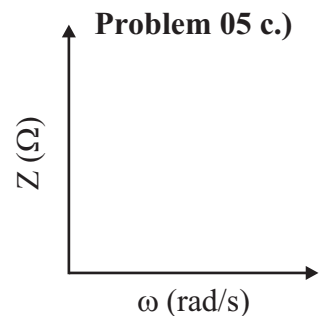
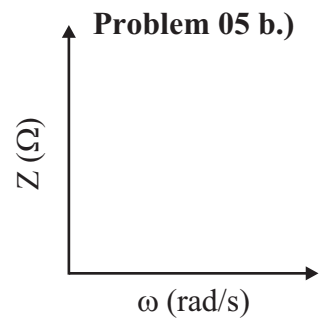
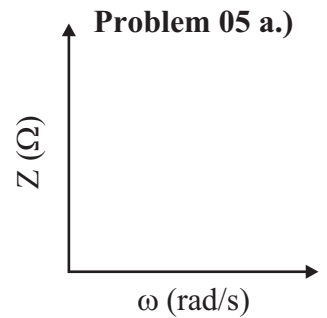

Problem 06

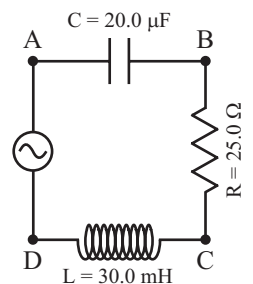

ANSWERS: 01. a.) 135 Ω b.) 0.704 c.) 0.157 A d.) 2.35 W 02. a.) 154 Ω b.) 0.518 c.) 0.778 A
 02. d.) 48.4 W 03. a.) 632 rad/s b.) $X_L = 31.6 \Omega$, $X_C = 31.6 \Omega$, $Z = 50.0 \Omega$, $I_{\text{rms}} = 1.00$ A, $\delta = 0$, $\cos \delta = 1$
 03. c.) $X_L = 150 \Omega$, $X_C = 6.67 \Omega$, $Z = 152 \Omega$, $I_{\text{rms}} = 0.329$ A, $\delta = 70.8^\circ$, $\cos \delta = 0.329$ 04. a.) 2.18-1.45 pF
 04. b.) 1.54 pF c.) 2092 06. a.) 0.969 A b.) 128 V c.) 24.2 V d.) 11.0 V e.) 131 V f.) 26.6 V
 06. g.) 330 mJ h.) 28.2 mJ i.) 1291 rad/s j.) 23.5 W k.) 23.5 W

Engineering Electric Circuits: AC Electric Circuits

LRC Circuits With a Generator/Rectification & Amplification Homework # 144

II

07. In the circuit shown to the right, the variable frequency ac generator produces an rms voltage of 120 V when operated at 60.0 Hz. Assume steady state conditions.
- Find the rms current that leaves the generator.
 - Find the rms current through the capacitor.
 - Find the rms current through the resistor.
 - Find the rms current through the inductor.
 - What is the phase angle, δ ?
 - What is the maximum energy stored in the capacitor?
 - What is the maximum energy stored in the inductor?
 - What is the resonant frequency of this circuit?
 - What is the minimum rms current for the resonant frequency?

Problem 07

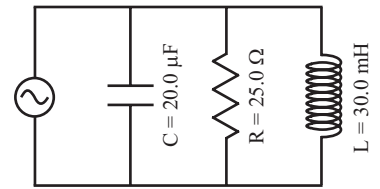

Rectification & Amplification

I

08. The maximum output current from a rectification circuit is 3.00 A. What is the rms current if the circuit is a _____ rectifier?
- full-wave
 - half-wave

09. In the circuit shown to the right, the variable frequency ac generator produces an rms voltage of 120 V, while $R = 25.0 \Omega$ and $C = 20 \mu\text{F}$.

Problems 09 & 10

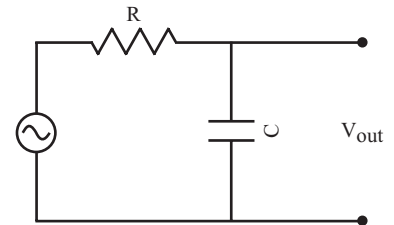

- What is the capacitive reactance when the frequency is 10.0 Hz?
- What is the impedance of the circuit when the frequency is 10.0 Hz?
- What is the rms current when the frequency is 10.0 Hz?
- What is the output rms voltage when the frequency is 10.0 Hz?
- What is the capacitive reactance when the frequency is 10,000.0 Hz?
- What is the impedance of the circuit when the frequency is 10,000.0 Hz?
- What is the rms current when the frequency is 10,000.0 Hz?
- What is the output rms voltage when the frequency is 10,000.0 Hz?
- Why is this called a low-pass filter?

II

10. For the circuit shown above and to the right, write an equation that describes output rms voltage, $V_{\text{out rms}}$, as a function of $V_{\text{in rms}}$, R , C , and ω .

11. In the circuit shown to the right, the variable frequency ac generator produces an rms voltage of 120 V, while $R = 25.0 \Omega$ and $C = 20 \mu\text{F}$. What is the output voltage when the frequency of the generator is _____?

Problems 11 & 12

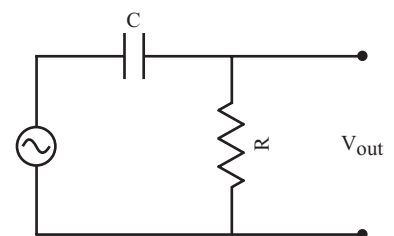

- 10.0 Hz
- 10,000.0 Hz
- Why is this called a high-pass filter?

12. For the circuit shown to the right, write an equation that describes output rms voltage, $V_{\text{out rms}}$, as a function of $V_{\text{in rms}}$, R , C , and ω .

ANSWERS: 07. a.) 10.8 A b.) 0.905 A c.) 4.80 A d.) 10.6 A e.) 41.9° f.) 0.288 J g.) 3.38 J
 07. h.) 205 Hz i.) 4.80 A 08. a.) 2.12 A b.) 1.06 A
 09. a.) 796Ω b.) 796Ω c.) 0.151 A d.) 119.9 V f.) 0.796Ω g.) 25.0Ω h.) 4.80 A i.) 3.81 V

10. $V_{\text{out rms}} = \frac{V_{\text{in rms}}}{\sqrt{\omega^2 C^2 R^2 + 1}}$ 11. a.) 3.76 V b.) 119.9 V 12. $V_{\text{out rms}} = \left(\frac{R}{\omega C}\right) \frac{V_{\text{in rms}}}{\sqrt{\omega^2 C^2 R^2 + 1}}$

Maxwell's Equations & Electromagnetic Waves

Maxwell's Equations/Electromagnetic Waves

Homework # 145

Maxwell's Equations

I

01. List Maxwell's four equations describing electric and magnetic fields.
02. Two square plates of a capacitor, 2.50 cm on a side, are charging causing the electric field between to increase at a rate of 3.0×10^6 V/m•s. Calculate the displacement current I_D of the capacitor.
03. A capacitor that has square parallel plates that are 1.75 cm on a side discharging via a wire connecting the two plates. If the current in the wire is 2.85 A, at what rate is the electric field changing between the plates?

II

04. A 4.35- μ F capacitor has two parallel circular plates that have a radius of 1.25 cm. The capacitor is being charged such that the plates are accumulating charge at the rate of 37.5 mC/s. What is the strength of the magnetic field at a location 9.00 cm radially away from the center of the plates?
05. Show that the displacement current through a parallel-plate capacitor can be described by $I_D = C(dV/dt)$, where V is the voltage on the capacitor at a given instant.

Electromagnetic Waves

I

06. An EM wave has a magnetic field peak of 1.35×10^{-11} T. What is the peak value of the electric field in the wave?
07. An EM wave is traveling south. Its E field oscillates horizontally (west and east) at 0.135 MHz with an rms strength of 4.25 V/m.
 - a.) What is the frequency of the magnetic field oscillations in this wave?
 - b.) What is the rms strength of the magnetic field oscillations in this wave?
 - c.) What is the peak strength of the magnetic field oscillations in this wave?
 - d.) What is the direction of the oscillations of magnetic field in this wave?

For problems involving calculations related to the EM spectrum see [Homework #156](#) of the chapter called "Light: Wave Nature"

ANSWERS: **02.** 1.66×10^{-8} A **03.** -1.05×10^{15} V/m•s **04.** 8.33×10^{-8} T **06.** 4.05×10^{-3} V/m
07. a.) 0.135 MHz b.) 1.42×10^{-8} T c.) 2.00×10^{-8} T d.) vertically up and down

Light: Geometric Optics

Speed of Light/Index of Refraction

Homework # 146

Use the table to the right throughout the chapter. Go online for a more complete listing of [Indices of Refraction](#) and a table of [Optical Glasses](#).

I

01. What is the speed of light in _____?
a.) acetone b.) sapphire
02. The speed of light in heavy flint glass is 1.81×10^8 m/s. What is the index of refraction of heavy flint glass?
03. What is the speed of light in diamond?
04. The speed of light in methylene iodide is 1.72×10^8 m/s. What is the index of refraction of methylene iodide?
05. How long does it take light from the sun to reach the earth? Assume space is a vacuum. See [Homework #26](#) for the table on Planetary Data in the chapter on Circular Motion.
06. How long does it take light from the sun to reach the Pluto? Assume space is a vacuum. See [Homework #26](#) for the table on Planetary Data in the chapter on Circular Motion.
07. The distance light travels in a year through a vacuum is known as a light-year (ly). Calculate this distance known as a light-year.
08. Alpha Centauri C is the closest star to our sun, Sol, at a distance of about 4.22 light-years (ly) away. This means it takes light from Alpha Centauri C 4.22 years to reach the earth. Approximately, how far away from the earth is Alpha Centauri C as measured in meters?

Indices of Refraction ($\lambda = 589$ nm)

Material	n = c/v
Vacuum	1.00000
Air (at STP)	1.00029
Acetone	1.36
Benzene	1.50
Calcite	1.68
Carbon Disulfide	1.63
Diamond	2.417
Ethyl Alcohol	1.36
Glass	
Arsenic Trisulfide	2.04
Fused Quartz	1.46
Crown Glass	1.52
Light Flint	1.58
Glycerine	1.473
Ice	1.31
Lucite or Plexiglass	1.51
Sapphire	1.77
Sodium Chloride	1.53
Water	1.33

II

09. Michelson measured the speed of light to be 2.99798×10^8 m/s using a rotating eight sided mirror located on Mount Wilson and a fixed mirror 35 km away on Mount Baldy (Mount San Antonio). Both mountains were located in the San Gabriel Mountains of California. What was the minimum angular velocity of Michelson's eight-sided mirror?

ANSWERS: **01.** a.) 2.21×10^8 m/s b.) 1.69×10^8 m/s **02.** 1.66 **03.** 1.24×10^8 m/s **04.** 1.74
05. 500 s = 8.33 min **06.** 19,667 s = 5.46 h **07.** 9.46×10^{15} m = 5.86×10^{12} mi **08.** 3.99×10^{16} m
09. 3364 rad/s

Light: Geometric Optics

Ray Diagrams for Mirrors

Homework # 147

1. REAL OR VIRTUAL
ERECT OR INVERTED
LARGER/SMALLER/SAME SIZE
FARTHER/CLOSER/SAME DISTANCE

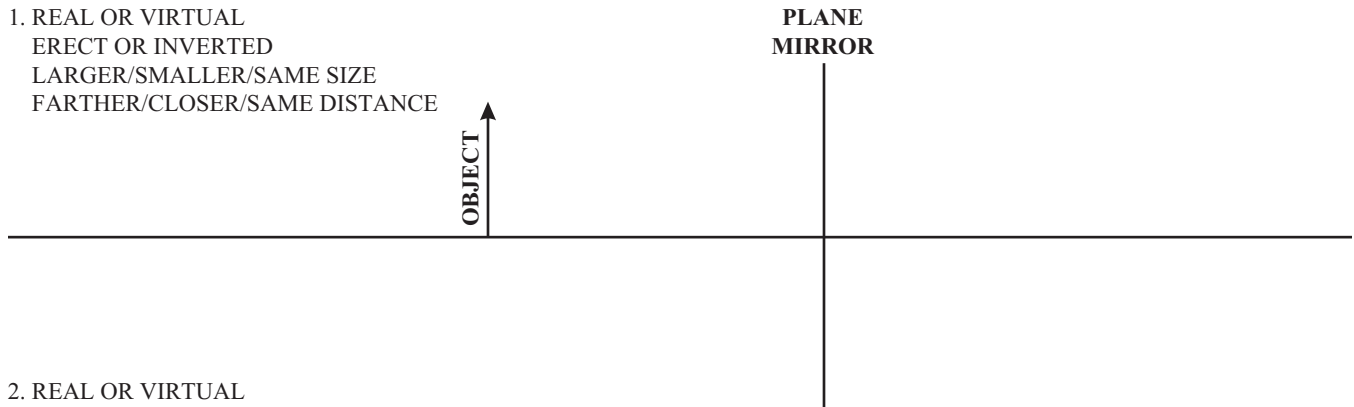

2. REAL OR VIRTUAL
ERECT OR INVERTED
LARGER/SMALLER/SAME SIZE
FARTHER/CLOSER/SAME DISTANCE

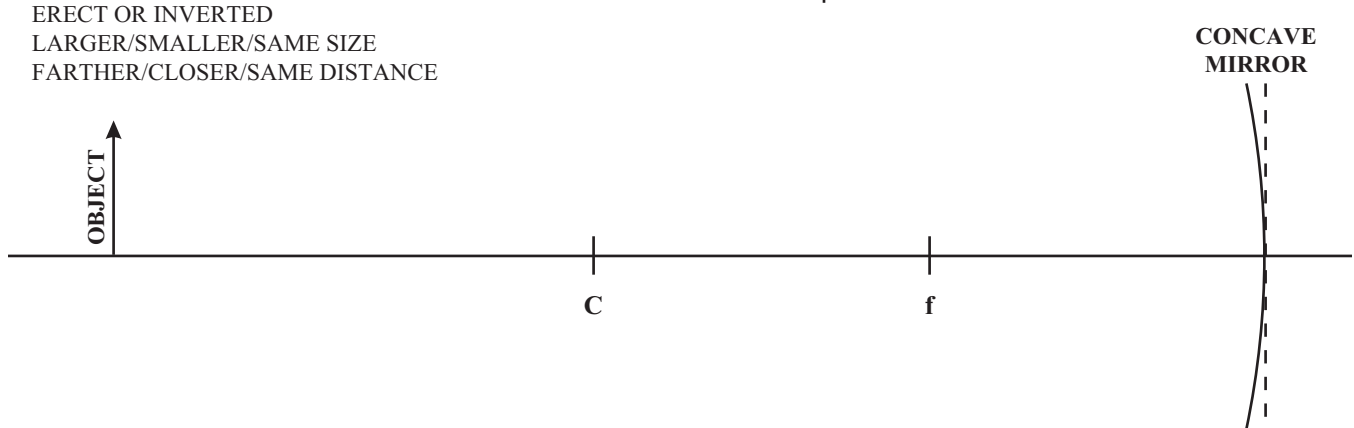

3. REAL OR VIRTUAL
ERECT OR INVERTED
LARGER/SMALLER/SAME SIZE
FARTHER/CLOSER/SAME DISTANCE

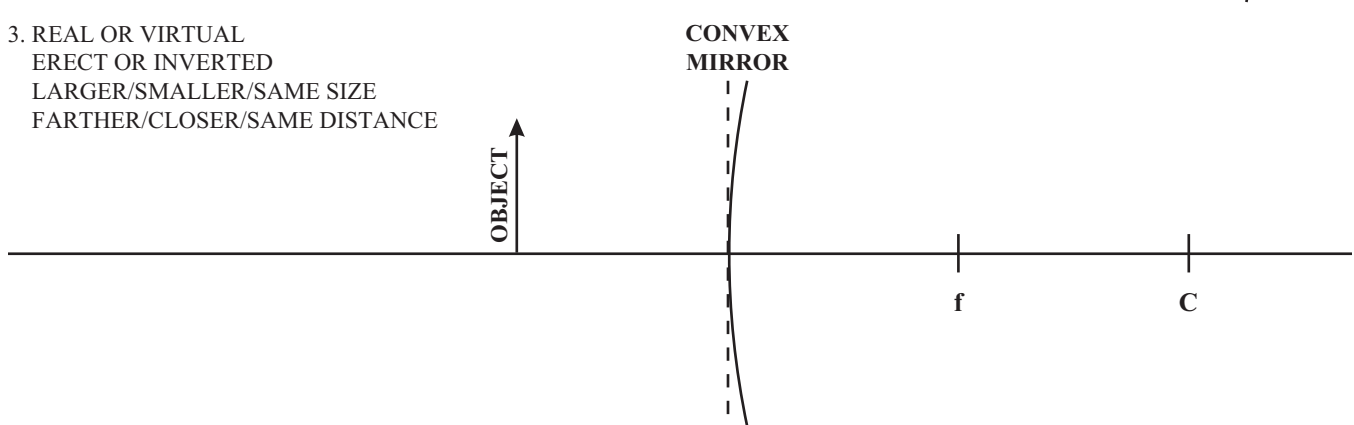

4. REAL OR VIRTUAL
ERECT OR INVERTED
LARGER/SMALLER/SAME SIZE
FARTHER/CLOSER/SAME DISTANCE

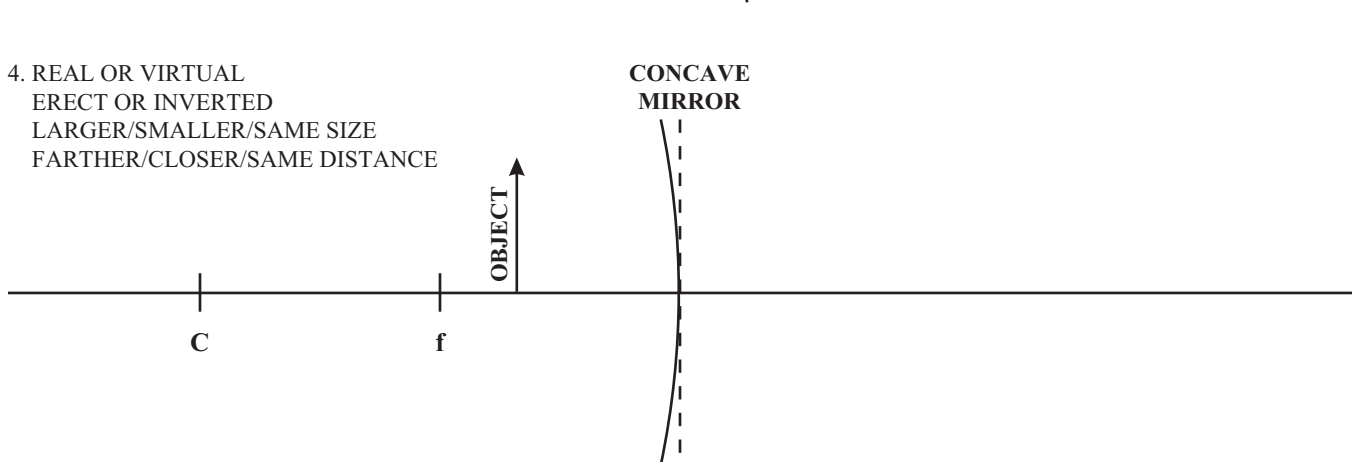

Light: Geometric Optics

Ray Diagrams for Mirrors

Homework # 148

5. REAL OR VIRTUAL
ERECT OR INVERTED
LARGER/SMALLER/SAME SIZE
FARTHER/CLOSER/SAME DISTANCE

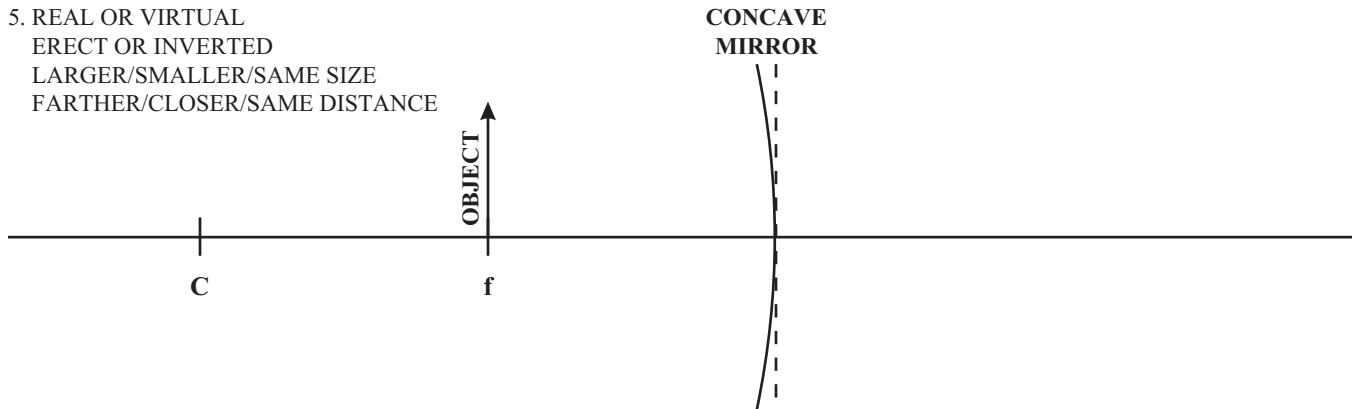

6. REAL OR VIRTUAL
ERECT OR INVERTED
LARGER/SMALLER/SAME SIZE
FARTHER/CLOSER/SAME DISTANCE

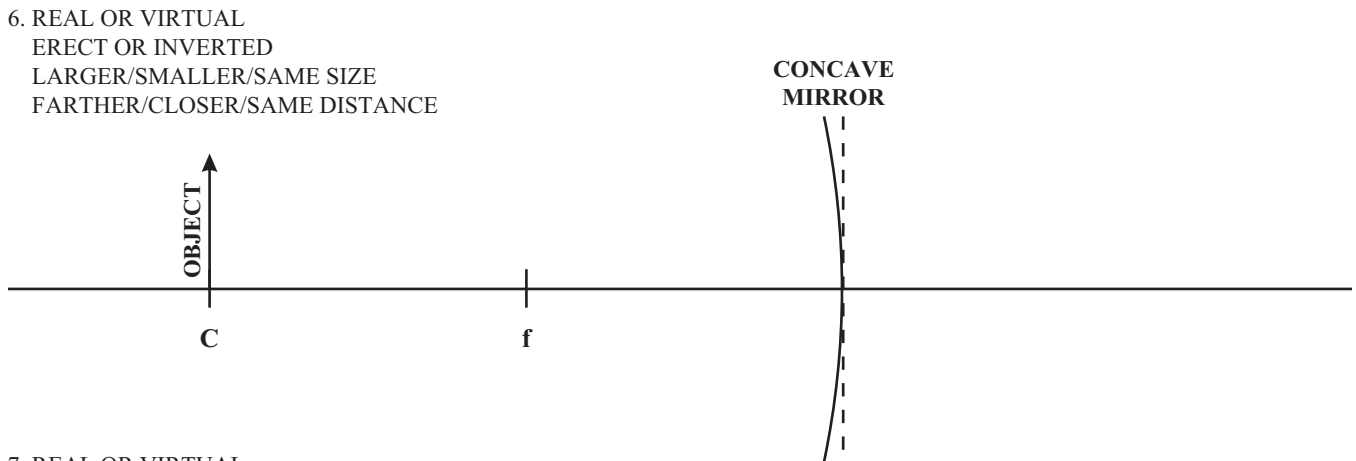

7. REAL OR VIRTUAL
ERECT OR INVERTED
LARGER/SMALLER/SAME SIZE
FARTHER/CLOSER/SAME DISTANCE

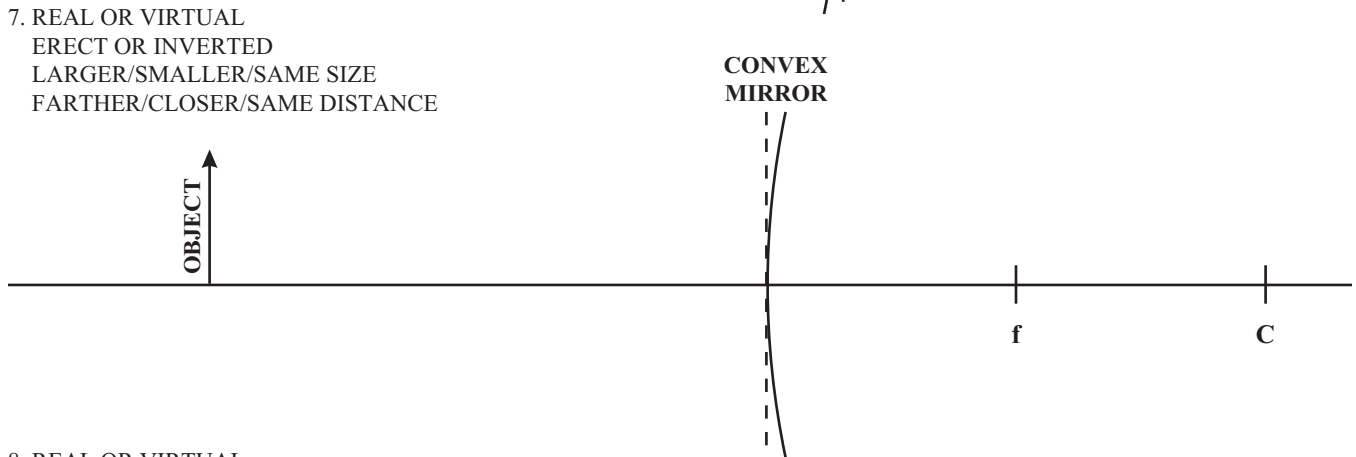

8. REAL OR VIRTUAL
ERECT OR INVERTED
LARGER/SMALLER/SAME SIZE
FARTHER/CLOSER/SAME DISTANCE

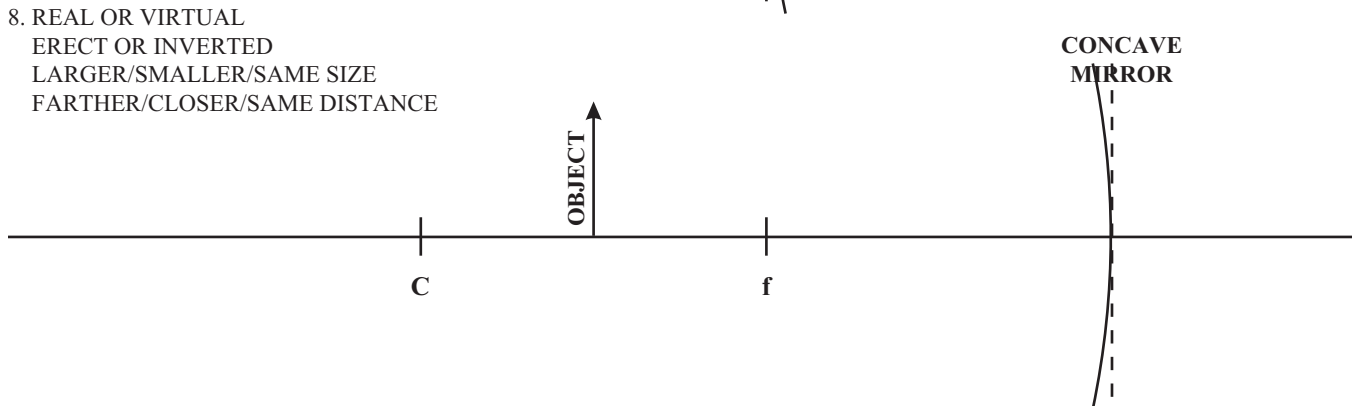

Light: Geometric Optics

Image Formation by Plane & Spherical Mirrors

Homework # 149

I

01. A photographer takes a picture of his own image from a plane mirror that is 3.25 m away. For what distance should the camera lens be focused?
02. Rays from a light source that is very far from a concave mirror are brought to a focus 12.5 cm from the front of the mirror.
- What is the focal length
 - What is the radius of curvature of the mirror?
 - What is the diameter of the sphere from which the mirror was cut?
03. A 6.25-cm tall object is placed 32.5 cm from a concave mirror with a focal length of 12.5 cm. Is the image _____.
- real or virtual
 - erect or inverted
 - size larger or smaller than the object
 - located farther or closer to the mirror than the object

II

04. A person whose eyes are 1.64 m above the floor stands 2.25 m in front of a flat mirror that is positioned on a wall such that its bottom edge is 52.5 cm above the floor. When she looks in the mirror, what is the smallest horizontal distance from the base of the wall to the point on the floor that is nearest to the wall that is visible in the mirror?
05. An polished silver ball with a diameter of 78.5 cm is placed on a ceramic pedestal as a lawn ornament. Someone standing 1.85 m away from the ball looks at her image in the ball.
- How far from the mirror will the image be located?
 - Is the image real or virtual?
 - Is the image easy to see, that is, what is the magnification of the image?
06. A 4.95-cm tall object is placed 44.3 cm from a spherical mirror producing a virtual image 6.25 cm from the mirror.
- What type of mirror is this?
 - What is the height of the image produced?
 - is the image upright or inverted?
07. A dentist uses a small mirror to be placed inside the mouth so that he can see a patient's teeth easier. One particular mirror produces a 5.25x upright image when placed 2.60 cm from the tooth.
- What kind of mirror is this?
 - What is the radius of curvature of this mirror?
08. How far from a concave mirror with a focal length of 22.5 cm must an object be placed to produce an image with a magnification of +3.65?
09. How far from a concave mirror with a focal length of 22.5 cm must an object be placed to produce an image with a magnification of -3.65?
10. What is the focal length of a mirror that produces magnification of +0.625 when an object is placed 2.50 m away?

ANSWERS: **01.** 6.50 m **02.** a.) 12.5 cm b.) 25.0 cm c.) 50.0 cm **03.** a.) real ($d_i = 20.3$ cm)
03. b.) inverted ($m = -0.625$) c.) smaller ($h_i = 3.91$ cm) d.) closer ($d_i < d_o$) **04.** 1.06 m **05.** a.) 17.7 cm
05. b.) virtual c.) no ($m = +0.0959$) **06.** a.) convex ($f = -7.28$ cm) b.) 0.698 cm c.) upright ($m = +0.141$)
07. a.) concave ($f = 3.21$ cm) b.) 6.42 cm **08.** 16.3 cm **09.** 28.7 cm **10.** -4.17 cm

Light: Geometric Optics

Refraction of Light-Snell's Law

Homework # 150

Refer to the table of Indices of Refraction found on [Homework #146](#) in this chapter.

I

01. A beam of light strikes a pane of glass with an index of refraction of 1.50 at an angle of 40.0° with the surface. What is the angle of refraction?
02. A boy dives into a pool, swims to the bottom, and looks up to see the sun at an angle of 18.5° with the normal to the surface. At what angle above the horizon is the sun at this moment?
03. A diver shines an underwater flashlight from the bottom of a lake such that it makes a 36.5° angle with the normal to the surface. At what angle will this light emerge from the surface of the lake?

II

04. A bright underwater flood light at the bottom of a 2.75-m deep pool is positioned 1.85 m from one edge of the pool. At what angle will light emerge from the surface of the water at the edge of the pool. Assume the pool is filled to the brim with water.
05. Light reflected from a small object strikes a flat pane of light flint glass at angle of 37.5° with the surface of the pane. At what angle with the surface will light emit from the other side of the pane?
06. A divers mask is made with a flat pane of glass ($n = 1.55$). While underwater, a diver sees an object that is actually located at angle of 23.0° below the level of his eyes. At what angle below the level of his eyes will the diver see the object? See the diagram to the right for the path of a light ray from the water, through the glass of the mask, and into the air that is trapped between the glass of the mask and the diver's face.

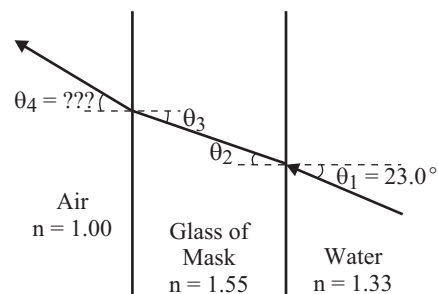

Problem 06

07. An equilateral prism made of crown glass is sitting on surface in a room filled with air. A beam of incident light strikes one side of the prism at a 55.0° angle with the normal to the surface as shown in the diagram to the right. Determine the angles in the diagram labeled θ_2 , θ_3 , and θ_4 .

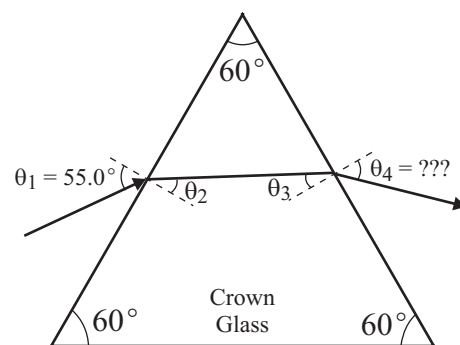

Problem 07

ANSWERS: **01.** 25.4° **02.** 25.0° **03.** 52.3° **04.** 47.9° **05.** $\theta_2 = 30.1^\circ$, $\theta_3 = 30.1^\circ$, $\theta_4 = 52.5^\circ$, $\theta_s = 37.5^\circ$
06. $\theta_2 = 19.6^\circ$, $\theta_3 = 19.6^\circ$, $\theta_4 = 31.3^\circ$ **07.** $\theta_2 = 32.6^\circ$, $\theta_3 = 27.4^\circ$, $\theta_4 = 44.4^\circ$

Light: Geometric Optics

Refraction of Light-Critical Angle

Homework # 151

Refer to the table of Indices of Refraction found on [Homework #146](#) in this chapter.

I

01. A diamond is dropped in a bathtub filled with water. What is the critical angle for light exiting the diamond?
02. The critical angle for a certain liquid-air surface is 47.3° .
a.) What is the index of refraction of this liquid? b.) What is the possible identity of this unknown liquid?
03. A beam of light is shown through the bottom of a beaker filled with an unknown liquid to a depth of 12.0 cm. The beam exits the surface of the liquid 11.0 cm from a point directly above the source of the light.
a.) What is the maximum index of refraction of this liquid?
b.) If the maximum index of refraction calculated in a.) above is the actual index of refraction, what is the possible identity of this unknown liquid?

III

04. Light strikes the end face of a cylindrical rod made of light flint glass. Show that a light ray entering an end face at any angle will be totally internally reflected. See the diagram to the right.
05. Light strikes one face of a prism at a 38.5° angle but is totally internally reflected at the opposite face. If the apex angle is 70.0° as shown in the diagram below, what can be said of the index of refraction of the glass? [Note: The following trigonometric identity may be useful: $\sin(\alpha - \beta) = \sin\alpha \cdot \cos\beta - \cos\alpha \cdot \sin\beta$]

Cylinder-Side View

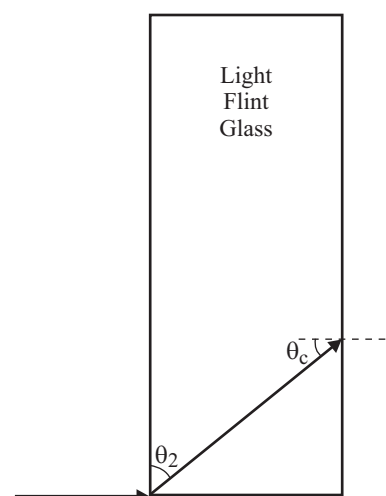

Problem 04

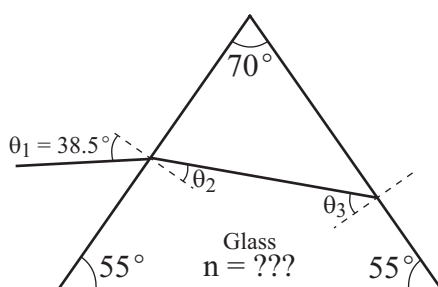

Problem 05

ANSWERS: **01.** 33.4° **02.** a.) 1.36 b.) Acetone, Ethyl Alcohol **03.** $n \geq 1.48$ b.) Glycerol
04. $\theta_2 = 39.3^\circ$, $\theta_c = 50.7^\circ$ **05.** $n \geq 1.43$ ($\theta_2 = 25.7^\circ$, $\theta_3 = 44.3^\circ$)

Light: Geometric Optics

Ray Diagrams for Lens

Homework # 152

1. REAL OR VIRTUAL
ERECT OR INVERTED
LARGER/SMALLER/SAME SIZE
FARTHER/CLOSER/SAME DISTANCE

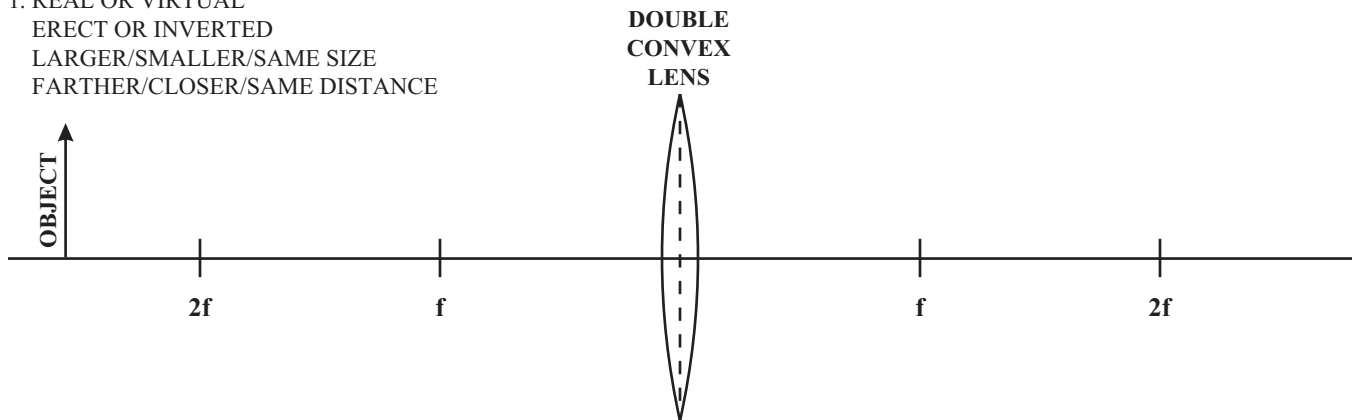

2. REAL OR VIRTUAL
ERECT OR INVERTED
LARGER/SMALLER/SAME SIZE
FARTHER/CLOSER/SAME DISTANCE

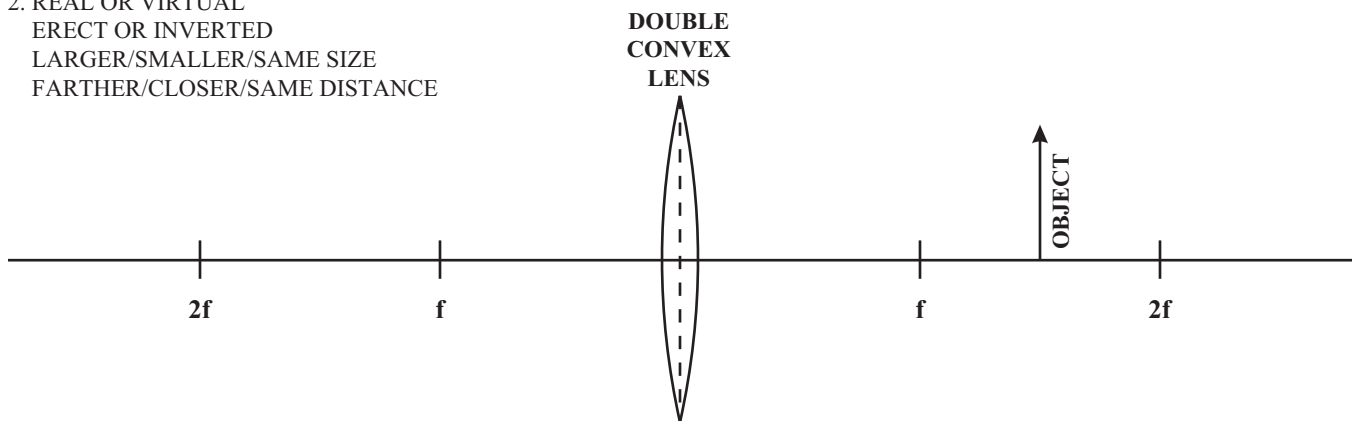

3. REAL OR VIRTUAL
ERECT OR INVERTED
LARGER/SMALLER/SAME SIZE
FARTHER/CLOSER/SAME DISTANCE

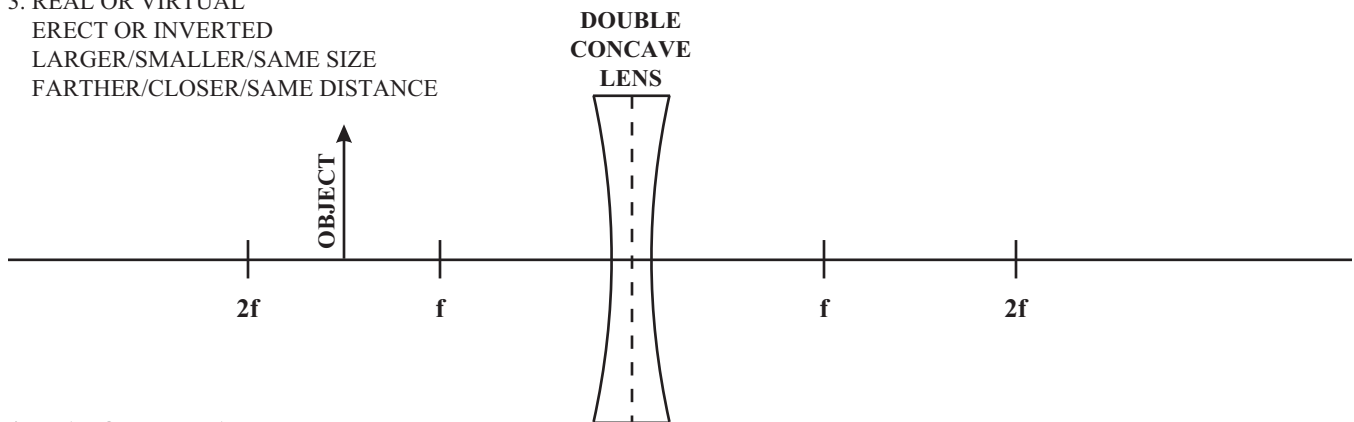

4. REAL OR VIRTUAL
ERECT OR INVERTED
LARGER/SMALLER/SAME SIZE
FARTHER/CLOSER/SAME DISTANCE

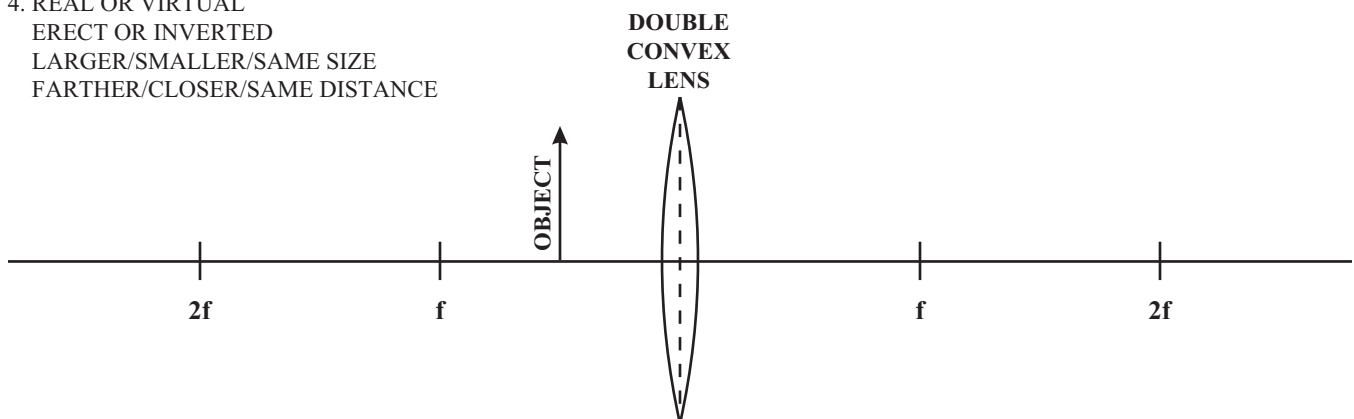

Light: Geometric Optics

Image Formation by Lens

Homework # 154

I

01. A converging lens with a focal length of 40.0 mm produces an image that is 47.5 mm from the lens. If this image is on the side of the lens opposite that of the object, how far away from the lens is the object located?
02. A bird's feather is placed 94.3 cm in front of a concave lens with a focal length of 850.0 mm. Is the image _____.
- a.) real or virtual b.) erect or inverted c.) larger or smaller d.) closer or farther
03. A 4.75-cm tall object is placed 48.6 cm from a lens produces an image 59.2 cm on the other side of the lens.
- a.) What type of lens is being used? b.) What will be the height of the image?

II

04. A magnifying glass (convex lens) with a focal length of 15.0 cm is being used to examine a coin. How far above the coin should the magnifier be held to produce a magnification of +4.50?
05. What is the focal length of a magnifying glass that produces a +5.25 magnification when held 12.5 cm from the newsprint that is being magnified?
06. A +7.50-D lens is held 18.8 cm from an ant. Is the image _____.
- a.) real or virtual b.) erect or inverted c.) larger or smaller d.) closer or farther
07. A -7.50-D lens is held 18.8 cm from an ant. Is the image _____.
- a.) real or virtual b.) erect or inverted c.) larger or smaller d.) closer or farther
08. The mean distance of the sun from the earth is 1.496×10^8 km. A camera with a 45.00 cm lens used to take a picture of the sun. The image of the sun produced on the film has a diameter of 4.194 mm. What is the approximate diameter of the sun?

ANSWERS: **01.** 253 mm (25.3 cm) **02.** a.) virtual ($d_i = -44.7$ cm) b.) erect ($m = +0.474$) c.) smaller
02. d.) closer **03.** a.) convex lens ($f = 26.7$ cm) b.) -5.79 cm **04.** 11.7 cm **05.** 15.4 cm
06. a.) real ($d_i = 45.9$ cm) b.) inverted ($m = -2.44$) c.) larger d.) farther
07. a.) virtual ($d_i = -7.80$ cm) b.) erect ($m = +0.415$) c.) smaller d.) closer **08.** 1.394×10^6 km

Light: Geometric Optics

Two-Lens Systems/Lens-Maker's Equation

Homework # 155

II

- An object is located 4.75 m from a simple optical system consisting of two lens. The first lens of this system has a focal length of 100 mm and the second lens which is 20.0 cm from the first lens has a focal length of 150.0 mm.
a.) What is the image distance for the second lens? b.) What is the magnification of the system?
- What is the focal length of a two-lens system, if the two lenses are 50.0 cm apart and have powers of +5.00 D and -3.60 D?
- What is the power of a two-lens system, if the two lens are touching and have powers of +5.00 D and -3.60 D?
- What is the power of a two-lens system, if the two lens are touching and have powers of +3.00 D and -3.00 D?

Corrective Lenses for the Human Eye

- An ophthalmologist prescribes a lens with a power of -4.75 D for a person's right eye. The eye is 2.10 cm from the lens when this person wears his glasses comfortably.
a.) Is this person nearsighted or farsighted? b.) What is this person's far point without glasses?
- A person has a near point of 145 cm. What power of reading glasses are needed to read at 25.0 cm? Assume that the distance between the eye and the lens of the glasses are 2.25 cm apart.
- The right eye of a person has a near point of 18.0 cm and a far point of 46.0 cm. An Optometrist prescribes contact lenses to correct the far vision so the person can see objects at a large distance away. Contact lenses are in direct contact with the eye (thus the name).
a.) What power lens are prescribed? b.) What will the person's near point be with this lens?
- The eyeglasses of a nearsighted person has one lens with a focal length of -30.0 cm and this lens is located 1.85 cm from the eye when the glasses are placed comfortably on the person's face. If this person wishes to switch to contact lenses, what focal length contact lens should be prescribed?
- A particular person has an eye in which the distance between the lens of the eye and the retina is 19.00 mm but the focal length of the lens of this eye is 17.00 mm. What focal length corrective contact lenses should be prescribed to see objects clearly?

Lens-Maker's Equation

- A double-convex lens with an index of refraction of 1.55 is made such that the radius of curvature of one side of the lens is 20.0 cm and the radius of curvature of the other side is 30.0 cm. What is the focal length of this lens?
- A double-concave lens with an index of refraction of 1.63 is made such that the radius of curvature of one side of the lens is 25.0 cm and the radius of curvature of the other side is 32.5 cm. What is the focal length of this lens?
- A concavo-convex lens with an index of refraction of 1.52 is made such that the radius of curvature of the concave side of the lens is 15.0 cm and the radius of curvature of the convex side is 22.5 cm. What is the focal length of this lens?

ANSWERS: **01.** a.) -28.1 cm b.) $m = +0.0593$ **02.** -14.4 cm **03.** 1.40 D **04.** $P = 0$ ($f = \infty$)
05. a.) near sighted b.) 23.2 cm **06.** +3.30 D **07.** a.) -2.17 D b.) 29.6 cm **08.** -3.14 D **09.** -161.5 mm
10. 21.8 cm **11.** -22.4 cm **12.** -86.5 cm

Light: Wave Nature

Electromagnetic Spectrum/Refraction of Light

Homework # 156

Electromagnetic Spectrum

01. A radar signal has a frequency of 12.25 GHz (1 GHz = 1.0×10^9 Hz). What is its wavelength?
02. What is the frequency of a microwave whose wavelength is 2.75 cm?
03. What is the wavelength of K-Rock's carrier wave at 92.3 MHz on the FM dial? (1 MHz = 1.0×10^6 Hz)
04. An X-ray has a wavelength of 2.50 Å ($1 \text{ Å} = 1 \times 10^{-10}$ m). What is its frequency?
05. What is the wavelength range of the visible portion of the EM spectrum?
06. Find the frequency for each of the following colors of light.
a.) red ($\lambda = 700$ nm) b.) violet ($\lambda = 400$ nm) c.) yellow ($\lambda = 589$ nm) d.) green (550 nm)
07. What portion of the EM spectrum has wavelengths _____ than visible light?
a.) shorter b.) longer

Refraction of Light

For problems 08-10, refer to [Homework #146](#) for the table of Indices of Refraction in the chapter on "Geometric Optics".

08. A source of light has a wavelength of 650 nm in air. What is the wavelength of light in crown glass?
09. A source of light has a wavelength of 650 nm in air. What is the wavelength of light in water?
10. A source of light has a wavelength of 650 nm in air. What is the wavelength of light in diamond?
11. The wavelength of light from a sodium lamp is 589 nm when in air. If the light from this lamp is determined to have a wavelength of 366 nm when traveling through turquoise, what is the index of refraction of turquoise?

ANSWERS: **01.** 2.45 cm **02.** 10.9 GHz **03.** 3.25 m **04.** 1.20×10^{18} Hz **05.** 400-700 nm
06. a.) 4.29×10^{14} Hz b.) 7.50×10^{14} Hz c.) 5.09×10^{14} Hz d.) 5.45×10^{14} Hz
07. a.) ultraviolet b.) infrared **08.** 428 nm **09.** 489 nm **10.** 269 nm **11.** 1.61

Light: Wave Nature

Diffraction & Interference-Double Slit Phenomenon Homework #157

I

01. A beam of 475-nm light strikes two closely-spaced slits. A third-order fringe is produced at angle of 32.5° to the direction of the initial beam. How far apart are the slits?
02. Monochromatic light falls on a two slits that are $12.3 \mu\text{m}$ apart. A diffraction and interference pattern is observed with a fifth-order fringe appearing at an angle of 12.4° with the original path of the light. What is the wavelength of this light?

II

03. A beam of 450-nm light strikes two slits that are $23.7 \mu\text{m}$ apart producing a diffraction and interference pattern on a screen 4.25 m away. How far apart are the fringes on the screen?
04. Monochromatic light falls on two slits that are 0.0525 mm apart producing a diffraction and interference pattern on a screen 6.50 m away with fringes that are 7.36 cm apart. What is the wavelength of light?
05. A parallel beam of 525-nm light passes through a double slit onto a screen that is 3.35 m away creating fringes that are 4.28 cm apart. How far apart are the slits?
06. Monochromatic light passes through two slits that are 0.025 mm apart onto a screen that is 2.85 m away. For each of the following wavelengths, determine the distance between fringes produced on the screen.
a.) 400 nm b.) 500 nm c.) 600 nm d.) 700 nm
07. A beam of 550-nm light passes through a double-slit onto a screen that is 2.85 m away and the distance between the fringes is measured. Once the measurement is made, the first double-slit is replaced by a second with a different distance between the slits. This experiment is repeated with a third and fourth trial, each time changing the double-slit spacing distance. For each of the following double-slit spacings, determine the distance between fringes produced on the screen.
a.) $25.0 \mu\text{m}$ b.) $50.0 \mu\text{m}$ c.) $75.0 \mu\text{m}$ d.) $100.0 \mu\text{m}$
08. Light with a wavelength of 480 nm strikes two slits that are $5.35 \times 10^{-2} \text{ mm}$ apart and illuminate a screen 3.95 m away with a diffraction and interference pattern. How far from the central fringe will the sixth-order fringe appear?
09. Visible white light hits two slits that are $80.0 \mu\text{m}$ apart producing successive rainbow patterns on a screen 4.75 m away.
a.) How far from the central fringe will the second order appear for the longest-wavelength red light?
b.) How far from the central fringe will the third order appear for the shortest-wavelength violet light?
c.) What can be said of the second and third "rainbows" produced?
10. Light with a wavelength of 650 nm strikes two slits that are $7.65 \times 10^{-5} \text{ m}$ apart and produce a diffraction and interference pattern on a screen 4.00 m away. How wide will the central fringe be that appears on the screen?

ANSWERS: **01.** $2.65 \mu\text{m}$ **02.** 528 nm **03.** 8.07 cm **04.** 594 nm **05.** $41.1 \mu\text{m}$
06. a.) 4.56 cm b.) 5.70 cm c.) 6.84 cm d.) 7.98 cm **07.** a.) 6.27 cm b.) 3.14 cm c.) 2.01 cm
07. d.) 1.57 cm **08.** 21.3 cm **09.** a.) 8.31 cm b.) 7.13 cm c.) overlap of 2nd & 3rd rainbows **10.** 3.40 cm

Light: Wave Nature

Diffraction & Interference-Single Slit Phenomenon Homework # 158

I

01. What is the angular width of the central diffraction peak when 490-nm light falls on a slit 40 μm wide?
02. Monochromatic light passes through a slit with a width of 36.0×10^{-3} mm creating a diffraction and interference pattern where the angle between the dark fringes on either side of the central maximum is 1.80° . What is the wavelength of light used?
03. Monochromatic light with a wavelength of 630 nm passes through a slit creating a central angular width of 38.4° . What is the width of this slit?

II

04. How wide is a central diffraction peak on a screen 3.60 m behind a slit, with a width of 0.0344 mm, when illuminated by 440-nm light?
05. If 530-nm light diffracts through a single slit producing a central-fringe width of 6.42 cm on a screen 3.40 m away, what must be the width of the slit?
06. Monochromatic light passes through a single slit with a width of 38 μm creating a central fringe that is 9.30 cm wide on a screen 4.20 m away. What is the wavelength of light used?

ANSWERS: **01.** 1.40° **02.** 565 nm **03.** 1.92 μm **04.** 9.21 cm **05.** 56.4 μm **06.** 421 nm

Light: Wave Nature

Polarization of Light

Homework # 161

I

01. Two polarizers have polarizing axes at a 45.0° angle to one another. What fraction of unpolarized light directed at this pair of polarizers will be transmitted through the pair?
02. Light passes through a polarizer blocking half of the light. What fraction of this **REMAINING** light will pass through a second polarizer at an angle of 45.0° to the first?
03. What is Brewster's angle for a flat piece of glass crown glass ($n = 1.52$) sitting in a room filled with air?
04. What is Brewster's angle for a flat piece of glass crown glass ($n = 1.52$) submerged in water?

II

05. At what angle should the polarizing axes of two polarizers be oriented so that one-eighth of the original intensity of light passes through?
06. Unpolarized light with an intensity of 240 foot-candles strikes two polarizers with polarizing axes at 35.0° to one another. What intensity of light will pass through the two polarizers?
07. The intensity of light that passes through a polarizer is 25.0 candelas. What intensity of this light will pass through an analyzer with a polarizing axis oriented at a 25.0° angle to the axis of the polarizer?
08. Polarized light with an intensity of 4200 foot-candles encounters a polarizer with an axis that is 18.0° with direction of the oscillating electric field of the polarized light. What intensity of this light will pass through the polarizer?
09. If 340 foot-candles of light falls upon a pair of polarizers reducing the intensity of light that exits the pair to 120 foot-candles, what is the angle between the polarizing axes of these two polarizers?
10. Sunlight strikes the surface of a lake.
 - a.) At what incident angle will light be totally polarized?
 - b.) What is the angle of refraction for the incident angle determined in part a.)?

ANSWERS: **01.** $\frac{1}{4}$ **02.** $\frac{1}{2}$ **03.** 56.7° **04.** 48.8° **05.** 60.0° **06.** 80.5 ft-can **07.** 20.5 cd **08.** 3800 ft-can
09. 32.8° **10.** a.) 53.1° b.) 36.9°

Special Relativity

Relativistic Momentum/Velocity Transformations Homework # 163

Useful Information: The rest mass of an electron is 9.11×10^{-31} kg, the rest mass of a proton is 1.67×10^{-27} kg.

Relativistic Momentum (Mass Increase)

I

01. What is the mass of a proton traveling at $0.95c$? (The rest mass of a proton is 1.67×10^{-27} kg)
02. What is the mass of an electron at the following speeds? (The rest mass of an electron is 9.11×10^{-31} kg)
a.) $0.9000c$ b.) $0.9900c$ c.) $0.9990c$ d.) $0.9999c$
03. What is the momentum of an electron at the following speeds? (The rest mass of an electron is 9.11×10^{-31} kg)
a.) $0.9000c$ b.) $0.9900c$ c.) $0.9990c$ d.) $0.9999c$
04. At what speed will the mass of an object be _____ times its rest mass?
a.) two b.) ten c.) one hundred d.) one thousand
05. In the Stanford Linear Accelerator at the Stanford Linear Accelerator Center (SLAC), electrons can attain a mass 10,000 times its rest mass. What is the speed of such electrons? (The rest mass of an electron is 9.11×10^{-31} kg)

III

06. What is the percent increase in mass for an object moving at the escape velocity of the earth? [Hint: To determine the escape velocity, an object must have a kinetic energy equal to the gravitational potential energy of an object at the surface of the earth $\left(\text{GPE} = G \frac{M_E m_o}{r}, \text{ where } \text{GPE} = 0 \text{ at } r = \infty \right)$]

Velocity Transformations

I

07. A person in a rocket traveling at $0.600c$ with respect to the earth observes a meteor approach and pass the rocket. This person measures the speed of the meteor to be $0.600c$ with respect to the rocket. What will astronomers on earth record as the speed of the meteor if it passes the rocket in the _____ direction as the rocket?
a.) same b.) opposite

II

08. Two spaceships leave the earth in opposite directions. The speed of each spaceship is identical and measured to be $0.750c$ with respect to the earth.
a.) What is the velocity of spaceship 1 relative to spaceship 2?
b.) What is the velocity of spaceship 2 relative to spaceship 1?
09. A spaceship leaves the earth traveling at $0.800c$. It fires a very small missile measured to have a velocity of $0.920c$ with respect to the spaceship. Since the mass of the missile is very small compared to the spaceship, assume the recoil effect of the spaceship is negligible such that it maintains its $0.800c$ velocity with respect to the earth. What is the velocity of the missile with respect to the earth if it is fired in _____ the spaceship?
a.) the same direction as b.) the opposite direction as c.) a direction perpendicular to that of

ANSWERS: **01.** 5.35×10^{-27} kg **02.** a.) 2.09×10^{-30} kg b.) 6.46×10^{-30} kg c.) 2.04×10^{-29} kg
02. d.) 6.44×10^{-29} kg **03.** a.) 5.64×10^{-22} kg•m/s b.) 1.92×10^{-21} kg•m/s c.) 6.11×10^{-21} kg•m/s
03. d.) 1.93×10^{-20} kg•m/s **04.** a.) $0.866c$ b.) $0.995c$ c.) $0.99995c$ d.) $0.9999995c \approx 1$ **05.** $0.925c$
06. $6.87 \times 10^{-8}\%$ **07.** a.) $0.882c$ b.) 0 **08.** a.) $0.960c$ opposite 2 b.) $0.960c$ opposite 1
09. a.) $0.991c$ b.) $-0.445c$ c.) $u_x = 0.800c, u_y = 0.883c$

Special Relativity

Relativistic Energy

Homework # 164

Useful Information: The rest mass of an electron is 9.11×10^{-31} kg, the rest mass of a proton is 1.67×10^{-27} kg.

- I
01. An electron is moving at $0.750c$. What is its _____?
a.) rest energy? b.) total energy? c.) kinetic energy? d.) momentum
02. A 1000.0-kg sample of water is heated from 0.00°C to 100.00°C ? The specific heat of water, $c = 4.18 \times 10^3$ kJ/kg.
a.) How much energy must be added to the water to produce this temperature change? [Remember, $Q = mc\Delta T$]
b.) What is the increase in mass of the water during this temperature change?
03. Assume exactly one gram of a material could be converted into energy.
a.) How much energy would be "released"?
b.) If this energy could be harnessed to lift an object 100 m (about the length of a football field) off the ground, what is the maximum mass that could be lifted to this height?
- II
04. Calculate the rest energy of _____ in J and MeV. [1 MeV = 1.60×10^{-13} J]
a.) an electron b.) a proton
05. An electron has a mass is 5 times its rest mass.
a.) What is the kinetic energy of this electron? b.) How fast is the electron traveling?
06. A proton is accelerated by a 750-MeV potential difference. What is the _____ of this proton?
a.) kinetic energy b.) total energy c.) momentum d.) speed
07. An electron has a kinetic energy that is half its total energy.
a.) What is the mass of the electron? b.) How fast is the electron traveling?
08. Assume a 45,000-kg spacecraft could be accelerated to $0.2250c$.
a.) Calculate its kinetic energy using classical physics.
b.) Calculate its kinetic energy using relativistic physics.
c.) What is the percent difference of the classical result from the relativistic result for kinetic energy?
d.) Calculate its momentum using classical physics.
e.) Calculate its momentum using relativistic physics.
f.) What is the percent difference of the classical result from the relativistic result for momentum?
- III
09. How much mass does the earth gain from the sun each year? [The radius of the earth is 6.38×10^6 m, the area of a sphere is πr^2 , radiation from the sun reaches the earth at the rate of 1400 W/m^2 . The area of a circle is used rather than the surface area of a sphere because the maximum 1400-W/m^2 rate of radiation striking the earth occurs when the sunlight is at right angles to the surface of the earth. The "horizontal" component of a sphere is a circle.]

ANSWERS: **01.** a.) 8.20×10^{-14} J b.) 1.24×10^{-13} J c.) 4.20×10^{-13} J d.) 3.10×10^{-22} kg
02. a.) 4.18×10^9 J b.) 6.64×10^{-8} kg **03.** a.) 9.00×10^{-13} J b.) 9.18×10^{10} kg
04. a.) 8.20×10^{-14} J (0.512 MeV) b.) 1.50×10^{-10} J (939.375 MeV) **05.** a.) 3.28×10^{-13} J b.) $0.980c$
06. a.) 1.20×10^{-10} J b.) 2.70×10^{-10} J c.) 7.49×10^{-19} kg d.) $0.882c$ **07.** a.) 1.82×10^{-30} kg b.) $0.882c$
08. a.) 1.025×10^{20} J b.) 1.066×10^{20} J c.) 3.813% d.) 3.038×10^{12} kg•m/s e.) 3.117×10^{12} kg•m/s
08. f.) 2.564% **09.** 6.27×10^7 kg

Quantum Mechanics & Atomic Structure

Photon Theory of Light & The Photoelectric Effect Homework # 165

For subatomic particle information see [Homework #91](#) of the Chapter called "Electrostatics"

I

01. What is the energy of a photon of light with a wavelength of _____?
a.) 400 nm b.) 700 nm
02. What is the wavelength of a 4.60-eV photon?
03. A local FM radio station has a carrier wave with a frequency of 104.3 MHz. What is the energy of the photons emitted from this station?
04. What is the minimum frequency of light that will emit electrons from the surface of gold which has a work function of 5.37?
05. Aluminum has a work function of 4.25 eV.
a.) What is the longest wavelength of light that will emit electrons from an aluminum surface?
b.) Is this in the visible region?

II

06. A surface of cesium, which has a work function of 2.14 eV, is illuminated by light with a wavelength of 525 nm.
a.) What is the maximum kinetic energy of the emitted electrons?
b.) What is the maximum speed of the emitted electrons?
07. When UV light of wavelength 175 nm falls on a tungsten surface, the maximum kinetic energy of the emitted electrons is 2.50 eV. What is the work function of tungsten?
08. What is the maximum kinetic energy of electrons emitted from a platinum source ($W_0 = 5.30$ eV) when light of wavelength _____ strikes it?
a.) 700 nm b.) 400 nm c.) 235 nm d.) 200 nm
09. When UV light of wavelength 225 nm falls on a lithium surface, the current through a photo electric circuit is brought to rest by a stopping potential of 2.62 V. What is the work function of lithium?
10. What is the maximum speed of electrons emitted from the surface of potassium ($W_0 = 2.30$ eV) when light of wavelength _____ falls on it?
a.) 700 nm b.) 400 nm c.) 235 nm d.) 200 nm

ANSWERS: **01.** a.) 3.11 eV b.) 1.78 eV **02.** 270 nm **03.** 4.32×10^{-7} eV **04.** 1.30×10^{15} Hz
05. a.) 293 nm b.) no **06.** a.) 0.228 eV b.) 2.83×10^5 m/s **07.** 4.60 eV **08.** a.) 0 eV b.) 0 eV c.) 0 eV
08. d.) 0.916 eV **09.** 2.90 eV **10.** a.) 0 m/s b.) 5.33×10^5 m/s c.) 9.34×10^5 m/s d.) 1.17×10^6 m/s

Quantum Mechanics & Atomic Structure

Photon Interactions

Homework # 166

For subatomic particle information see [Homework #91](#) of the Chapter called "Electrostatics"

I

01. An X-ray photon has a wavelength of 0.475 nm.
a.) What is the momentum of this photon?
b.) What is the energy of this photon?
c.) What is its effective mass?
02. A 3.75-MeV photon interacts with a nearby nucleus to produce an electron-positron pair. What total kinetic energy will this pair possess?
03. A $\mu^+ - \mu^-$ (muon-muon) pair are produced by a photon. The mass of each μ is 207 times that of an electron.
a.) What is the minimum energy of the photon? b.) What is the wavelength of the photon?

II

04. A photon produces an electron-positron pair, each with a kinetic energy of 565 keV.
a.) What is the energy of the photon? b.) What is the wavelength of the photon?
05. An electron is accelerated from rest through a potential difference of 5000 V. At this point it collides with a positron that was accelerated through the same potential difference? The two particles annihilate each other and form a photon. Assume classical physics-ignore relativistic effects.
a.) What is the energy of the photon? b.) What is the wavelength of the photon?
06. A positron traveling at 1.95×10^7 m/s collides with and annihilates an electron traveling at 3.65×10^7 m/s. Assume classical physics-ignore relativistic effects.
a.) What is the wavelength of the photon that forms? b.) What is the momentum of the photon that forms?
07. A 0.604-nm photon strikes a free electron, initially at rest, in a perfectly elastic head-on collision demonstrating the Compton effect. Assuming classical physics (ignore relativistic effects), what is the wavelength of the recoiling photon if the electron travels off at 2.40×10^6 m/s?

III

08. A 0.250-nm photon strikes a free electron, initially at rest, in a perfectly elastic head-on "collision" demonstrating the Compton effect. Assume classical physics-ignore relativistic effects.
a.) What is the speed of the electron after the interaction with the photon?
a.) What is the kinetic energy of the electron after the interaction with the photon?
b.) What is the wavelength of the recoiling photon?

ANSWERS: **01.** a.) 1.40×10^{-24} kg•m/s b.) 4.19×10^{-16} J c.) 4.65×10^{-33} kg **02.** 2.73 MeV
03. a.) 212 MeV b.) 5.86×10^{-15} m **04.** a.) 2150 keV (2.15 MeV) b.) 5.77×10^{-13} m
05. a.) 1.03 MeV b.) 1.20×10^{-12} m **06.** a.) 1.20×10^{-12} m b.) 4.97×10^{-5} kg•m/s **07.** 0.608 nm
08. a.) 5.77×10^6 m b.) 94.7 eV c.) 0.255 nm

Quantum Mechanics & Atomic Structure

de Broglie Wavelength of Matter Waves

Homework # 167

For subatomic particle information see [Homework #91](#) of the Chapter called "Electrostatics"

I

01. A 140-g baseball is pitched at 32.7 m/s. What is the wavelength of this ball?

02. What is the wavelength of a proton traveling at 3250 m/s?

II

03. What is the wavelength of an electron with _____ of energy? Are any of these in the visible region?

- a.) 1 eV b.) 10 eV c.) 100 eV d.) 1000 eV

04. What is the wavelength of an electron that is accelerated across a voltage of _____?

- a.) 1 V b.) 10 V c.) 100 V d.) 1000 V

05. What is the wavelength of a proton with _____ of energy? Are any of these in the visible region?

- a.) 1 eV b.) 10 eV c.) 100 eV d.) 1000 eV

06. What is the wavelength of a proton that is accelerated across a voltage of _____?

- a.) 1 V b.) 10 V c.) 100 V d.) 1000 V

07. An electron and a proton have the same wavelength. What is the ratio of the speed of the electron to that of the proton? (Assume the speeds are much less than the speed of light.)

08. An electron and a proton have the same nonrelativistic kinetic energy. What is the ratio of their wavelengths?

III

09. Using the rms speed of an oxygen molecule at a room temperature of 25.0°C, determine its wavelength?

Remember, $KE_{\text{ave}} = \frac{3}{2}kT = \frac{1}{2}mv^2$ (where, Boltzmann's constant, $k = 1.38 \times 10^{-23}$ J/K and Avogadro's number, $N_A = 6.02 \times 10^{23}$ molecules/mole).

10. A beam of electrons accelerated through a potential difference of 40,000 V passes through an aluminum foil, that consists of atoms about 10^{-10} m apart, onto a plate of film 10.0 cm away. Assuming a linear diffraction and interference pattern, how far apart would constructive interference peaks appear on the film? Note: the actual interference pattern more closely simulates a disk diffraction producing a concentric circular pattern of constructive and destructive interference.

ANSWERS: **01.** 1.45×10^{-34} m **02.** 0.122 nm **03.** a.) 1.24 μ m b.) 124 nm c.) 12.4 nm d.) 1.24 nm
04. a.) 1.24 μ m b.) 124 nm c.) 12.4 nm d.) 1.24 nm **05.** a.) 1.24 μ m b.) 124 nm c.) 12.4 nm
05. d.) 1.24 nm **06.** a.) 1.24 μ m b.) 124 nm c.) 12.4 nm d.) 1.24 nm **07.** 1830 **08.** 42.8 (0.0234)
09. 2.59×10^{-11} m **10.** 3.27 cm

Quantum Mechanics & Atomic Structure

The Bohr Model of Atomic Structure

Homework # 168

I

01. What is the wavelength of the third Balmer line ($n = 5$ to $n = 2$ transition)?
02. An hydrogen atom emits light that is the second longest wavelength in the Lyman series.
a.) What transition does this represent? b.) What wavelength results from this transition?
03. How much energy is needed to ionize a hydrogen atom with an electron in the $n = \underline{\hspace{2cm}}$ state?
a.) 1 b.) 2 c.) 3 d.) 4

II

04. Construct the energy level diagram for the hydrogen atom and show the transitions for the Lyman, Balmer, and Paschen series. Include values for the first five energy levels.
05. Construct the energy level diagram for the He^+ ion. Include values for the first five energy levels.
06. Construct the energy level diagram for the Li^{2+} ion. Include values for the first five energy levels.
07. What is the longest wavelength of light that can ionize a hydrogen atom in its ground state?
08. What are the potential and kinetic energies of an electron in the ground state of hydrogen?
09. The electron in a hydrogen atom de-excites from the $n = 7$ energy level to the $n = 4$ energy level.
a.) How much energy is emitted by this transition?
b.) What wavelength of light will be emitted by this transition?
10. The electron in a hydrogen atom de-excites from the $n = 9$ energy level to the $n = 5$ energy level.
a.) How much energy is emitted by this transition?
b.) What wavelength of light will be emitted by this transition?
11. A "blue" photon with a wavelength of 488 nm strikes the electron in a hydrogen atom and disappears. What energy level transition did this electron undergo?
12. A "UV" photon with a wavelength of 95.2 nm strikes the electron in a hydrogen atom and disappears. What energy level transition did this electron undergo?
13. A "infrared" photon with a wavelength of 1.10 μm strikes the electron in a hydrogen atom and disappears. What energy level transition did this electron undergo?

ANSWERS: **01.** 435 nm **02.** a.) $n = 3$ to $n = 1$ b.) 103 nm **03.** a.) 13.6 eV b.) 3.40 eV c.) 1.51 eV
03. d.) 0.85 eV **04.** $E_1 = 13.6$ eV, $E_2 = 3.40$ eV, $E_3 = 1.51$ eV, $E_4 = 0.85$ eV, $E_5 = 0.544$ eV
05. $E_1 = 54.4$ eV, $E_2 = 13.6$ eV, $E_3 = 6.04$ eV, $E_4 = 3.40$ eV, $E_5 = 2.176$ eV
06. $E_1 = 122.4$ eV, $E_2 = 30.6$ eV, $E_3 = 13.6$ eV, $E_4 = 7.65$ eV, $E_5 = 4.896$ eV **07.** 91.4 nm
08. PE = -27.2 eV, KE = 13.6 eV **09.** a.) 0.572 eV b.) 2.17 μm **10.** a.) 0.376 eV b.) 3.31 μm
11. $n = 4$ to $n = 2$ **12.** $n = 5$ to $n = 1$ **13.** $n = 6$ to $n = 3$

Quantum Mechanics & Atomic Structure

Heisenberg Uncertainty Principle/Quantum Numbers Homework # 169

For subatomic particle information see [Homework #91](#) of the Chapter called "Electrostatics"

Heisenberg Uncertainty Principle

I

01. A proton's position can be measured to an accuracy of 1.45×10^{-8} m. With what accuracy can its velocity be determined?
02. An electron is traveling with a speed of 6.750×10^5 m/s with a possible error of $\pm 1.5 \times 10^3$ m/s. What is the maximum accuracy with which its position can be determined?
03. An electron it remains in an excited state of a hydrogen atom for an average of 10^{-8} s.
 - a.) What is the minimum uncertainty in the energy of this electron?
 - b.) What percentage of the ground state energy is this uncertainty?

II

04. Suppose a baseball with a mass of 140 g and an electron are traveling at the same speed of 32.7 m/s with the same uncertainty in this speed of 0.125 percent.
 - a.) What is the uncertainty in the position of the baseball?
 - b.) What is the uncertainty in the position of the electron?

Quantum Numbers

I

05. What values of l are possible for $n = 6$?
06. Electrons of an atom are being assigned possible quantum numbers. For the $n = 7, l = 3$ subshell, _____?
 - a.) what are the possible values of m_l
 - b.) how many electrons will it take to fill the subshell
07. List the possible states of the principal quantum number $n = 4$ and state how many possible states are present.
08. What is the maximum number of _____ that may occupy $n = 5, l = 2$ subshell?
 - a.) magnetic quantum numbers
 - b.) electrons
09. What is the maximum number of _____ that may occupy $n = 6$ energy level?
 - a.) orbital quantum numbers
 - b.) magnetic quantum numbers
 - c.) electrons
10. List the quantum numbers for each electron in the ground state of an atom of calcium ($Z = 20$).
11. What is the magnitude of angular momentum of an electron in the $n = 6, l =$ _____ state of a hydrogen atom.
 - a.) 2
 - b.) 3
 - c.) 4
 - d.) 5
12. Write the electron configuration notation for an atom in the ground state of the element _____?
 - a.) C ($Z = 6$)
 - b.) S ($Z = 16$)
 - b.) Rb ($Z = 37$)
 - d.) U ($Z = 92$)

ANSWERS: **01.** 4.36 m/s **02.** 7.72×10^{-8} m **03.** 6.59×10^{-8} eV **b.)** 4.85×10^{-7} % **04.** a.) 1.84×10^{-32} m
04. b.) 2.83 mm **05.** 0, 1, 2, 3, 4, 5 **06.** a.) -3, -2, -1, 0, 1, 2, 3 **b.)** 14 **07.** 32 **08.** a.) 5 **b.)** 10
09. a.) 6 **b.)** 36 **c.)** 72 **11.** a.) 2.58×10^{-34} J•s **b.)** 3.66×10^{-34} J•s **c.)** 4.72×10^{-34} J•s **d.)** 5.78×10^{-34} J•s

Nuclear Physics

Selected Isotope Masses

Homework # 170

Atomic Number Z	Element	Symbol	Mass Number A	Atomic Mass	Atomic Number Z	Element	Symbol	Mass Number A	Atomic Mass			
1	Hydrogen	H	1	1.007825	23	Vanadium	V	51	50.943962			
	Deuterium	D	2	2.014102		24	Chromium	Cr	52	51.940511		
	Tritium	T	3	3.016049			25	Manganese	Mn	55	54.938048	
2	Helium	He	3	3.016029	26	Iron		Fe	56	55.934940		
			4	4.002602			27		Cobalt	Co	59	58.933198
3	Lithium	Li	6	6.015121	60	59.933820						
			7	7.016928	28	Nickel	Ni	58	57.935346			
4	Beryllium	Be	7	7.016928				60	59.930789			
			9	9.012182	29	Copper	Cu	63	62.929599			
5	Boron	B	10	10.012936				65	64.927791			
			11	11.009305	30	Zinc	Zn	64	63.929144			
6	Carbon	C	11	11.011433				66	65.926035			
			12	12.000000	31	Gallium	Ga	69	68.925580			
			13	13.003355				32	Germanium	Ge	72	71.922079
			14	14.003242	74	73.921177						
7	Nitrogen	N	13	13.005738	33	Arsenic	As	75	74.921594			
			14	14.003074				34	Selenium	Se	80	79.916519
			15	15.000108							35	Bromine
8	Oxygen	O	15	15.003065	84	83.911508						
			16	15.994915	37	Rubidium	Rb	85	84.911793			
			18	17.999160				38	Strontium	Sr	86	85.909266
9	Fluorine	F	19	18.998404	88	87.905618						
			20	19.992435	90	89.907737						
10	Neon	Ne	22	21.991383	39	Yttrium	Y	89	88.905847			
			11	Sodium				Na	22	21.994434	40	Zirconium
23	22.989767	41			Niobium	Nb	93		92.906376			
24	23.990961						42		Molybdenum	Mo	98	97.905407
12	Magnesium	Mg	24	23.985042	43	Technetium		Tc			98	97.907215
			13	Aluminum			Al		27	26.981538	44	Ruthenium
14	Silicon	Si			28	27.976927		45	Rhodium	Rh		
			31	30.975362	46	Palladium	Pd				106	105.903481
15	Phosphorus	P	31	30.973762				47	Silver	Ag	107	106.905091
			32	31.973908	109	108.904754						
16	Sulfur	S	32	31.972071	48	Cadmium	Cd	114	113.903359			
			35	34.969033				49	Indium	In	115	114.903876
17	Chlorine	Cl	35	34.968853	50	Tin	Sn				120	119.902197
			37	36.965903				51	Antimony	Sb	121	120.903820
18	Argon	Ar	40	39.962384	52	Tellurium	Te				130	129.906228
			19	Potassium				K	39	38.963708	53	Iodine
40	39.964000	131			130.906111							
20	Calcium	Ca	40	39.962591								
			21	44.955911								
21	Scandium	Sc	45	44.955911								
22	Titanium	Ti	48	47.947947								

Nuclear Physics

Selected Isotope Masses

Homework # 171

Atomic Number Z	Element	Symbol	Mass Number A	Atomic Mass	Atomic Number Z	Element	Symbol	Mass Number A	Atomic Mass
54	Xenon	Xe	132	131.904141	83	Bismuth	Bi	209	208.980374
			136	135.90721				211	210.987254
55	Cesium	Cs	133	132.905436	84	Polonium	Po	210	209.982848
56	Barium	Ba	137	136.905816				214	213.995177
			138	137.905236	85	Astatine	At	218	218.00868
57	Lanthanum	La	139	138.906346				86	Radon
58	Cerium	Ce	140	139.905434	87	Francium	Fr		
59	Praseodymium	Pr	141	140.907647				88	Radium
60	Neodymium	Nd	142	141.907718	89	Actinium	Ac		
61	Promethium	Pm	145	144.912745				90	Thorium
62	Samarium	Sm	152	151.919728	232	232.038051			
63	Europium	Eu	153	152.921226	91	Protactinium	Pa	231	231.035880
64	Gadolinium	Gd	158	157.924099				92	Uranium
65	Terbium	Tb	159	158.925344	233	233.039630			
66	Dysprosium	Dy	164	163.929172	235	235.043924			
67	Holmium	Ho	165	164.930320	236	236.045562			
68	Erbium	Er	166	165.930292	238	238.050784			
69	Thulium	Tm	169	168.934213	239	239.054289			
70	Ytterbium	Yb	174	173.938861	93	Neptunium	Np	239	239.052932
71	Lutecium	Lu	175	174.940772				94	Plutonium
72	Hafnium	Hf	180	179.946547	95	Americium	Am		
73	Tantalum	Ta	181	180.947993				96	Curium
74	Tungsten	W	184	183.950929	97	Berkelium	Bk		
75	Rhenium	Re	187	186.955746				98	Californium
76	Osmium	Os	191	190.960922	99	Einsteinium	Es		
77	Iridium	Ir	192	191.961468				100	Fermium
			193	192.962916	101	Mendelevium	Md		
78	Platinum	Pt	195	194.964765				102	Nobelium
79	Gold	Au	197	196.966543	103	Lawrencium	Lr		
80	Mercury	Hg	199	198.968253				104	Rutherfordium
			202	201.970617	105	Dubnium	Db		
81	Thallium	Tl	205	204.974400				106	Seaborgium
82	Lead	Pb	206	205.974440	107	Bohrium	Bh		
			207	206.975871				108	Hassium
			208	207.976627	109	Meitnerium	Mt		
			210	209.984163					
			211	210.988734					
			212	211.991872					
214	213.999798								

Nuclear Physics

Nuclear Structure/Binding Energy & Nuclear Forces Homework # 172

Nuclear Structure

I

01. What is the rest energy of an α particle?
02. Convert the mass of a pi meson ($139 \text{ MeV}/c^2$) to atomic mass units.

II

03. What is the approximate radius of a ${}^{60}_{28}\text{Ni}$ nucleus?
04. What is the approximate value of A for a nucleus with a radius of $4.8 \times 10^{-15} \text{ m}$?
05. How much energy must an α particle have to just barely "touch" the surface of a ${}^{238}_{92}\text{U}$ nucleus? [Hint: The α particle must have enough (kinetic) energy to overcome the electrostatic potential energy that exists when the two nuclei touch (radius of α particle plus radius of ${}^{238}_{92}\text{U}$ nucleus).]

Binding Energy & Nuclear Forces

I

06. Estimate the total binding energy of _____.
a.) ${}^{16}_8\text{O}$ b.) ${}^{35}_{16}\text{S}$ c.) ${}^{197}_{79}\text{Au}$ d.) ${}^{208}_{82}\text{Pb}$

II

07. Calculate the total _____ for ${}^9_4\text{Be}$.
a.) binding energy b.) binding energy per nucleon
08. What is the binding energy of the last neutron in a ${}^{14}_7\text{N}$ nucleus? [Hint: compare the mass of the ${}^{14}_7\text{N}$ to the combined mass of ${}^{13}_7\text{N} + {}^1_0\text{n}$.]
09. How much energy would be required to remove a single neutron from a ${}^{14}_7\text{N}$ nucleus?
10. Show that the nucleus ${}^8_4\text{Be}$ (mass = 8.005308 u) is unstable to decay into two α particles.
11. Determine if ${}^{12}_6\text{C}$ is stable against decay into three α particles.

ANSWERS: **01.** 3728.4 MeV **02.** 0.149 u **03.** $4.70 \times 10^{-15} \text{ m}$ **04.** 64 **05.** 28.4 MeV
06. a.) 127.6 MeV b.) 298.8 MeV c.) 1559.4 MeV d.) 1636.5 MeV **07.** a.) 58.2 MeV b.) 6.46 MeV
08. 10.55 MeV **09.** 10.55 MeV **10.** $m_{2\alpha \text{ particles}} < m_{{}^8_4\text{Be}}$ ($8.005204 \text{ u} < 8.005308 \text{ u}$)
11. $m_{3\alpha \text{ particles}} > m_{{}^{12}_6\text{C}}$ ($12.007806 \text{ u} > 12.000000 \text{ u}$)

Nuclear Physics

Half-Life and Rate of Decay

Homework # 174

I

01. A sample radioactive material produces 1560 decays per minute when first tested and 390 decays per minute 8.00 h later. What is its half-life?
02. What is the half-life of $^{24}_{11}\text{Na}$ if it has a decay constant of $1.287 \times 10^{-5} \text{ s}^{-1}$?
03. What is the decay constant of $^{235}_{92}\text{U}$ which has a half-life of 7.038×10^8 years?
04. What is the activity of a sample of $^{14}_6\text{C}$ that contains 8.45×10^{21} nuclei, if it has a half-life of 5730 years?
05. What fraction of a sample of $^{32}_{15}\text{P}$, which has a half-life of about 14 days, will remain after 42 days?
06. How many nuclei of $^{115}_{49}\text{In}$, which has a half life of 4.41×10^{14} years, are present in an iron ore if an activity registers 3.40 decays per second?

II

07. A sample of $^{231}_{91}\text{Pa}$ ($T_{\frac{1}{2}} = 3.276 \times 10^4 \text{ yr}$) contains 6.45×10^{16} nuclei.
 - a.) What is the decay constant?
 - b.) What is the approximate number of decays/min?
08. The activity of a 3.85- μg pure sample of $^{31}_{14}\text{Si}$ ($T_{\frac{1}{2}} = 157.3$ minutes) is being monitored.
 - a.) How many nuclei are initially present?
 - b.) What is the initial activity?
 - c.) How many nuclei are present after 9.00 h?
 - d.) What is the activity after 9.00 h?
 - e.) How much time elapses from the start of monitoring until the activity drops to 1.00 % of the original sample?
 - f.) How much time elapses from the start of monitoring will the activity to drop to about 1 per second?
09. What is the activity of a 7.65- μg pure sample of $^{191}_{76}\text{Os}$ ($T_{\frac{1}{2}} = 1.33 \times 10^6 \text{ s}$)?
10. The activity of a sample of $^{131}_{53}\text{I}$ ($T_{\frac{1}{2}} = 6.95 \times 10^5 \text{ s}$) is 7.35×10^9 decays/sec. What is the mass of the sample?
11. The activity of a sample drops by a factor of 10 in 72.4 minutes.
 - a.) What is its half-life?
 - b.) What might be the identity of this nuclide?
12. A 27.5-g sample of pure carbon is 1.10% $^{14}_6\text{C}$ ($T_{\frac{1}{2}} = 5730 \text{ yr}$). How many disintegrations occur each second?
13. A radioactive nuclide produces 6740 decays per minute initially, and 1400 decays per minute exactly 1 day later.
 - a.) What is its half-life?
 - b.) What might be the identity of this nuclide?

ANSWERS: **01.** 4.00 h **02.** $5.39 \times 10^4 \text{ s}$ (15.0 h) **03.** $3.12 \times 10^{-17} \text{ s}^{-1}$ **04.** 3.24×10^{10} decays/s **05.** $\frac{1}{8}$
06. 6.82×10^{22} nuclei **07.** a.) $6.71 \times 10^{-13} \text{ s}^{-1}$ b.) 2.60×10^6 decays/s **08.** a.) 7.48×10^{16} nuclei
08. b.) 5.50×10^{12} decays/s c.) 6.93×10^{15} nuclei d.) 5.09×10^{11} decays/s e.) 17.4 h f.) 111 h
09. 1.26×10^{10} decays/s **10.** 1.60 μg **11.** a.) 21.8 minutes b.) $^{223}_{87}\text{Fr}$ **12.** 4.99×10^{10} decays/s
13. a.) 10.6 h b.) $^{212}_{82}\text{Pb}$